

# TRP Six-Bolt to CenterLock Adapter

## INSTALLATION GUIDE

TRP Cycling Components  
688 W. Amidan Dr. 4X-1  
Ogden, UT 84404  
Toll Free: 1-877-807-4162  
Direct: 1-650-965-4442  
Email: info@trpcycling.com  
Web: www.trpcycling.com

## SAFETY WARNINGS & INFORMATION

**WARNING** - Disc brakes offer a significant increase in performance over traditional cable actuated systems. Follow the break-in recommendations listed in this manual, allow yourself time to learn and become accustomed to the braking characteristics.

**WARNING** - Disc brakes, calipers, and rotors get VERY HOT during regular use. DO NOT touch or attempt to service the rotor or caliper until you've allowed for sufficient cooling to occur.

**WARNING** - Leaking oil indicates a potential BRAKE FAILURE. If you're system is leaking oil stop immediately and determine the nature of the problem. DO NOT continue to ride a leaking system.

**WARNING** - If your bike is involved in a fall or crash, fully check the brake function including: the lever, caliper and rotor are securely attached to the bike, pads are correctly installed and functioning, the cable, (if applicable) is operating smoothly and the lever feels firm when applying the brake. Always have a qualified mechanic check the brakes if you have any doubts.

**WARNING** - Pad thickness must be at least 0.8mm of pad material. Confirm this before each ride. Keep pads clean and free of oil or hydraulic fluid. If pads become contaminated, discard and replace.

**WARNING** - TRP/Tektro braking systems are designed for use on a single rider bicycle. Use of these system on any other vehicle or apparatus will void the warranty, possibly causing you great personal harm or injury.

**CAUTION** - Read this manual completely before attempting to install or work on your TRP/Tektro brakes. If you are unfamiliar with any element of assembly or maintenance of TRP/Tektro braking systems please consult a qualified mechanic for assistance.

**CAUTION** - Only use TRP/TEKTRO branded replacement mineral oil when servicing the brakes. Other disc brake fluids, ESPECIALLY DOT based oils, will harm the system and compromise braking performance.

**CAUTION** - Cleanliness is a very important part of any maintenance of a TRP/Tektro brake system. If the pads or rotor become contaminated with oil, or if the system becomes contaminated with impurities, braking performance will be greatly impaired.

**CAUTION** - As with any oil, precautions in handling and clean up of any spills should be handled according to accepted best practices as governed by your state or country. Our Mineral oil is non-toxic, but clean up any spills promptly and completely. If Mineral Oil gets in your eyes IMMEDIATELY FLUSH WITH WATER for several minutes and go to the hospital. If Mineral oil gets on your skin RINSE IMMEDIATELY with soap and water. Do not inhale Mineral Oil, it is harmful. If inhaled move to a well ventilated environment and proceed to the hospital for appropriate care. If you ingest Mineral oil it may cause vomiting and/or diarrhea.

TRP hydraulic disc brakes are warranted against manufacturing defects in materials and / or workmanship for a period of two years from the date of original retail purchase. Not covered under this warranty is damage resulting from improper installation, adjustment or maintenance, lack of maintenance, alterations, crashes or use judged by TRP to be excessive or abusive. For warranty related questions or more information please contact a TRP Service Center or email at info@trpcycling.com

## REQUIRED TOOLS

- Six-Bolt to CenterLock Adapter
- CenterLock Ring Installation Tool (16 External Notch or 12 Internal Notch)
- T25 Torx Wrench
- Isopropyl Alcohol
- Clean Towel or Rag

## ROTORS AND LOCK RINGS

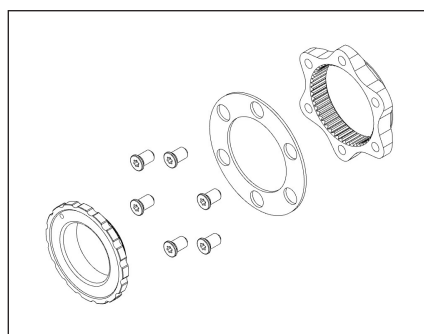

Six-Bolt to CenterLock Adapter

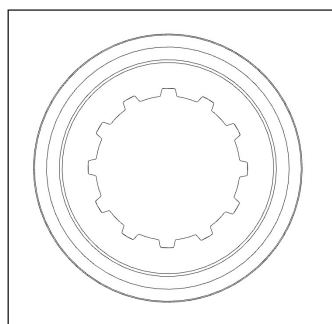

12 mm Lockring

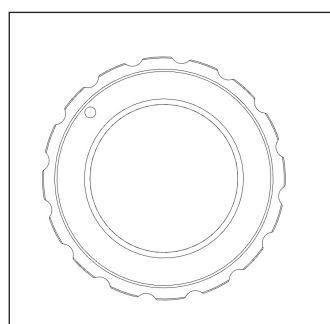

15/20 mm Lockring

### ROTORS

Six-bolt rotors come in one-piece or two-piece construction. Each rotor can have a different initial thickness; 1.8 mm thick or 2.3 mm thick. 2.3 mm thick rotors are typically used in e-bike and downhill specific applications whereas 1.8 mm thick rotors are used in lighter weight applications such as cross-country and trail riding. Six-bolt rotors can be mounted onto CenterLock hubs using an adapter.

Rotors come in several different diameters; Ø140 mm, Ø160 mm, Ø180 mm, Ø203 mm, Ø220 mm, and Ø223 mm. It is up to the rider to determine which rotor sizes will suite their riding style.

### LOCK RINGS

CenterLock rotors use either a lock ring with internal notches or external notches. Lock rings with internal notches are used for hubs with a 12 mm axle. Lock rings with external notches are used for hubs with 15 mm and 20 mm axles.

### ROTOR MINIMUM THICKNESS

Initial Rotor Thickness	1.8 mm Rotor	2.3 mm Rotor
Rotor Minimum Thickness	1.5 mm Rotor	1.8 mm Rotor

## MOUNTING SIX-BOLT ROTORS TO THE ADAPTER

Before installing the new rotor, clean the mounting surface of the hub thoroughly with isopropyl alcohol and a clean towel or rag. Install the adapter onto the hub. Mount the rotor to the adapter using the six T25 bolts and a T25 Torx wrench. Tighten the rotor bolts to 4 - 6 Nm in an alternating pattern. (Fig 1)

Determine the size of lock ring you will need. (12 mm axles use the smaller lock ring with 12 internal notches. 15 and 20 mm axles use the larger lock ring with 16 external notches.) Install the spacer and hand tighten the lock ring. (Fig 2) For 12 mm axles use a cassette installation tool. (Fig 3) For 15 mm and 20 mm axles use a bottom bracket installation tool. (Fig 4) Tighten the lock ring to 40 Nm. Clean the braking surfaces of the rotor using isopropyl alcohol and a clean towel or rag.

NOTE: Rotor must be installed with the "rotation" arrow pointing in the same direction as the forward rotation of the wheel.

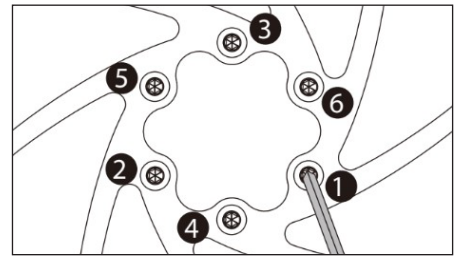

Fig 1

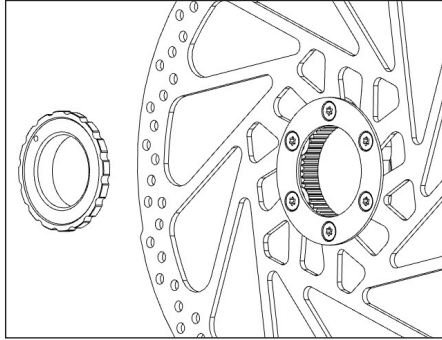

Fig 2

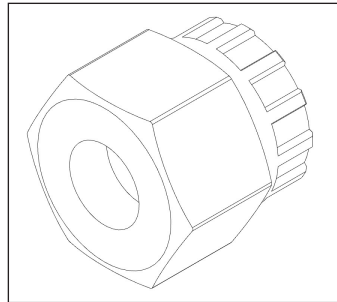

Fig 3

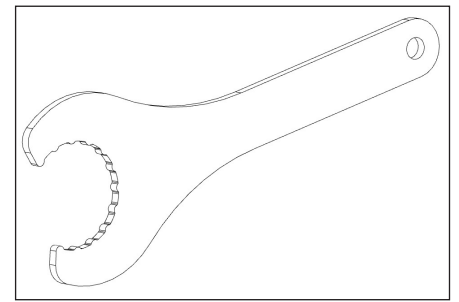

Fig 4

## PAD AND ROTOR BED-IN PROCEDURE

Bedding in your new pads and rotors is critical to the performance of the brakes. Properly bedding-in your pads and rotors will ensure the highest performance and best operating conditions.

Accelerate your bike to a moderate speed and apply the brakes. Slow the bike to a walking speed and then release the brakes. Repeat this process 15 - 20 times to transfer the pad material to the braking surface of the rotor. You will feel the brakes becoming more powerful throughout this process.

Accelerate your bike to a higher speed and apply more pressure to the brake lever until at a walking speed. Release the lever and repeat this process 10 - 15 times. Allow the brakes to cool before continuing to ride.

NOTE: Do not come to a complete stop at any time during this process. Doing so can lead to uneven pad material deposition and can affect the performance of the brakes while riding.

## TROUBLESHOOTING GUIDE

Braking power loss	Glazed pads	Remove the pads and remove the top layer with sand paper. Scuff the braking surface of the rotor with sand paper or steel wool. Clean with isopropyl alcohol and a clean rag or towel.
	Contaminated Pads and/or Rotor	Replace the pads AND the rotor. If you replace only the pads or only the rotors, there is a risk of continued contamination.
Noise at certain points in rotation	Bent rotor	Identify where the rotor is bent and use rotor truing tool to bend it the opposite direction. Repeat until rotor is no longer bent. Replace the rotor if you or a bike shop is unable to correct the issue.
Constant squeal when brakes are applied	Worn pads	Replace pads
	Uneven braking surface in rotor	Replace rotor
	Contaminated Pads and/or Rotor	Replace the pads AND the rotor. If you replace only the pads or only the rotors, there is a risk of continued contamination.

## GENERAL MAINTENANCE

### PAD REPLACEMENT

Pads should be replaced if they become contaminated or have less than 2.5mm thickness. (Pad friction material & metal backing plate). (Fig 4)

### BEFORE RIDING

Check the pads for wear or contamination.  
Check the hose for cracking, wear or deformation. Replace if necessary.  
Check that the brake system is operating correctly.

### AFTER RIDING

Remove any mud or contamination from the rotor slot on the caliper.  
Clean the caliper body with a cloth.

### AT REGULAR INTERVALS

Check the oil level in the reservoir.  
Lubricate the brake lever pivot with grease.  
Check to make sure that all the bolts are tightened to the correct torque specifications.

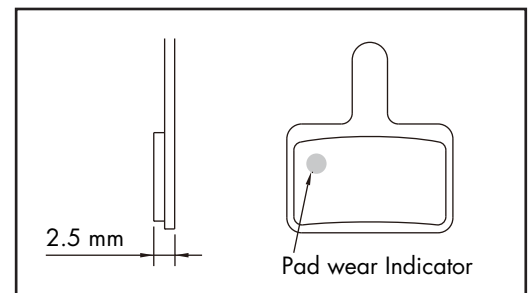

Fig 4