

**Shortening Disposal Unit**  
**(SDU 50, SDU 90 and BKSDU)**  
Installation, Operation, Service and Parts Manual



Frymaster, a member of the Commercial Food Equipment Service Association, recommends using CFESA Certified Technicians.

24-Hour Service Hotline 1-800-551-8633

SEPTEMBER 2005

\* 8195703 \*

[www.frymaster.com](http://www.frymaster.com)

E-mail: [service@frymaster.com](mailto:service@frymaster.com)

**NOTICE**

IF, DURING THE WARRANTY PERIOD, THE CUSTOMER USES A PART FOR THIS ENODIS EQUIPMENT OTHER THAN AN UNMODIFIED NEW OR RECYCLED PART PURCHASED DIRECTLY FROM FRYMASTER DEAN, OR ANY OF ITS AUTHORIZED SERVICE CENTERS, AND/OR THE PART BEING USED IS MODIFIED FROM ITS ORIGINAL CONFIGURATION, THIS WARRANTY WILL BE VOID. FURTHER, FRYMASTER DEAN AND ITS AFFILIATES WILL NOT BE LIABLE FOR ANY CLAIMS, DAMAGES OR EXPENSES INCURRED BY THE CUSTOMER WHICH ARISE DIRECTLY OR INDIRECTLY, IN WHOLE OR IN PART, DUE TO THE INSTALLATION OF ANY MODIFIED PART AND/OR PART RECEIVED FROM AN UNAUTHORIZED SERVICE CENTER.

**NOTICE**

Drawings and photos used in this manual are intended to illustrate operational, cleaning and technical procedures and may not conform to on-site management operational procedures.

** WARNING**

Improper installation, adjustment, alteration, service or maintenance can cause property damage, injury or death. Read the installation, operating and maintenance instructions thoroughly before installing, operating or servicing this equipment.

** DANGER**

Hot vegetable oil will cause severe burns. Allow vegetable oil to cool to 100°F (38°C) before transporting to the disposal site. Use extreme caution when transporting and disposing of spent vegetable oil.

** DANGER**

Before each use inspect the cover to ensure the cover gasket is present and properly placed. **DO NOT** use the disposal unit if this gasket is damaged or missing.



**Shortening Disposal Unit (SDU)  
Installation, Operation, Service, and Parts Manual**

**TABLE OF CONTENTS**

|   | <b>Page</b> |
|---|-------------|
| <b>1. INTRODUCTION .....</b>                                      | <b>1</b>    |
| <b>1.1 Service Information and Parts Ordering .....</b>           | <b>1</b>    |
| <b>1.2 Installation, Operating and Service Personnel .....</b>    | <b>1</b>    |
| <b>1.3 Definitions .....</b>                                      | <b>1</b>    |
| <b>1.4 Shipping Damage Claim Procedure .....</b>                  | <b>2</b>    |
| <b>1.5 What To Do If Your Equipment Arrives Damaged .....</b>     | <b>2</b>    |
| <b>2. ASSEMBLY AND OPERATION .....</b>                            | <b>2</b>    |
| <b>2.1 Equipment Description .....</b>                            | <b>2</b>    |
| <b>2.2 Equipment Assembly .....</b>                               | <b>3</b>    |
| <b>2.3 Equipment Operation .....</b>                              | <b>3</b>    |
| <b>2.4 Cleaning.....</b>  | <b>5</b>    |
| <b>3. SERVICE PROCEDURES.....</b>                                 | <b>5</b>    |
| <b>3.1 General .....</b>  | <b>5</b>    |
| <b>3.2 Replacing Worn or Damaged O-Rings.....</b>                 | <b>5</b>    |
| <b>3.3 Replacing Worn Pump Vanes and/or Pump Shaft Seal .....</b> | <b>5</b>    |
| <b>4. PARTS LIST.....</b>   | <b>7</b>    |

# SHORTENING DISPOSAL UNIT (SDU 50, SDU 90 AND BKSDU) INSTALLATION, OPERATION, SERVICE AND PARTS

---

## 1. INTRODUCTION

### 1.1 Service Information and Parts Ordering

Included with the unit when shipped from the factory is a list of Factory Authorized Service Centers (FASCs). Refer to this list to find the FASC nearest you. If you do not have access to this list, contact the Frymaster Technical Service Department at 1-800-551-8633 or 1-318-865-1711.

Service information may be obtained by contacting your local FASC. Information may also be obtained by calling the Frymaster Technical Service Department at 1-800-551-8633 or 1-318-865-1711 or by e-mail: [service@frymaster.com](mailto:service@frymaster.com). In order to assist you as quickly as possible, the FASC or Service Department representative requires certain information about your equipment. The information is printed on a data plate located on the tank cover. When requesting service, please have the following information ready:

**Model Number:** \_\_\_\_\_  
**Serial Number:** \_\_\_\_\_

In addition to the model number, and serial number, please be prepared to describe the nature of the problem and have ready any other information that you think may be helpful in solving your problem. Parts orders may be placed directly with your local FASC or distributor. When ordering parts, the following information is required:

**Model Number:** \_\_\_\_\_  
**Serial Number:** \_\_\_\_\_  
**Item Part Number:** \_\_\_\_\_  
**Quantity Needed:** \_\_\_\_\_

**RETAIN AND STORE THESE INSTRUCTIONS IN A SAFE PLACE FOR FUTURE USE.**

### 1.2 Installation, Operating and Service Personnel

Installation, Operating, and Service information for this equipment has been prepared for use by qualified and/or authorized personnel only, as defined in Section 1.3.

### 1.3 Definitions

#### **QUALIFIED AND/OR AUTHORIZED OPERATING PERSONNEL**

Qualified/authorized operating personnel are those who have carefully read the information in this manual and have familiarized themselves with the equipment functions, or who have had previous experience with the operation of the equipment covered in this manual.

#### **QUALIFIED SERVICE PERSONNEL**

Qualified service personnel are those who are familiar with this equipment and who have been authorized by Frymaster L.L.C. to perform service on equipment manufactured by Frymaster. All authorized service personnel are required to be equipped with a complete set of service and parts

manuals, and to stock a minimum amount of parts for Frymaster equipment. A list of Factory Authorized Service Centers (FASCs) was included with this equipment when shipped from the factory. *Unless specifically indicated otherwise in this manual, failure to use qualified service personnel will void the Frymaster Warranty on this equipment.*

#### 1.4 Shipping Damage Claim Procedure

This equipment was carefully inspected and packed before leaving the factory. The transportation company assumes full responsibility for safe delivery upon acceptance of the equipment for transport.

#### 1.5 What to Do If Your Equipment Arrives Damaged

1. **File a claim for damages immediately**, regardless of the extent of damages.
2. **Inspect for and record all visible loss or damage** and ensure that this information is noted on the freight bill or express receipt and is signed by the person making the delivery.
3. **Concealed loss or damage** that was unnoticed until the equipment was unpacked should be recorded and reported to the freight company or carrier **immediately** upon discovery. A concealed damage claim must be submitted within 15 days of the date of delivery. Ensure that the shipping container is retained for inspection.



**Frymaster DOES NOT ASSUME RESPONSIBILITY FOR DAMAGE OR LOSS INCURRED IN TRANSIT.**

## 2. ASSEMBLY AND OPERATION

### 2.1 Equipment Description

The Shortening Disposal Unit (SDU) is designed for the safe transportation of used shortening or cooking oil from the kitchen to a disposal container. There are two sizes – the SDU 50 (holding up to 50 lbs./23 kg) and the SDU 90 (holding up to 90 lbs./41 kg) of shortening. Both sizes are identical in construction and operation except for the volume of shortening that can be handled. The units consist of a tank to receive waste shortening/oil from a fryer and a heavy-duty manual pump for transferring the shortening/oil to a disposal container. Both models are equipped with 7" (178 mm) wheels and foldable handles. The pump is mounted at a convenient height that allows it to be operated from a standing position. The height of the discharge pipe allows pumping directly into a standard 55-gallon drum.

The BKSDU is equipped with a 120VAC or 240VAC tank heater to prevent solid shortening from solidifying prior to disposal. The BKSDU is equipped with a receptacle that accepts a three-prong, grounded plug for protection against shock hazard. The power cord should be plugged directly into a properly grounded, three-hole wall or floor receptacle. Do not cut off, remove, or otherwise bypass the grounding prong on the power cord plug. **CAUTION: Risk of fire and electric shock. Replace only with manufacturer's cord set, part number 8071224 for 120V or part number 106-4697 for 240V.**

With the cover open, the top of the tank is 9¾ inches (248 mm) above the floor, permitting it to be positioned directly beneath the drains of most fryers. (**NOTE:** The tanks on SDUs built before January 2004 are 11½ inches (292 mm) high.). If using an SDU built before January 2004, the filter pan cover on Frymaster PRO Series electric and gas fryers must be removed to allow the unit to be positioned beneath the drain.

A variant of the SDU 50, the BKSDU is equipped with a 120V or 240V heater to prevent shortening from solidifying in the reservoir.

## 2.2 Equipment Assembly

Assembly of the unit is a four-step process:

1. Remove the two bolts (or lock pins if manufactured prior to May 2006) from the handle-mounting bracket and raise the handle to the upright position. Reinstall the bolts (or lock pins) in the bracket.
2. Ensure the O-rings and the bottom 2 inches of the suction tube are lubricated with *Accrolube with Teflon* or an equivalent light oil or grease.
3. Turn the pump and suction tube upside down and carefully pour no more than one cup of cooking oil down the tube. Rotate the pump handle slowly three or four times to prime the pump.
4. Insert the suction tube through the pipe bracket on the handle and into the pickup tube on top of the reservoir. Push down on the pump assembly and ensure the suction tube is fully seated.

## 2.3 Equipment Operation

### WARNING

**DO NOT use this unit to dispose of water or Boil-out solution. Introduction of water or solvents into the unit will permanently damage the pump.**

1. Turn the fryer off prior to draining into SDU. If so equipped, ensure the fryer drainpipe is firmly threaded into the frypot drain valve.
2. Open the cover, verify that the crumb screen and rubber gasket on the inside cover are in place, and position the unit so that the opening is directly under the frypot drainpipe.

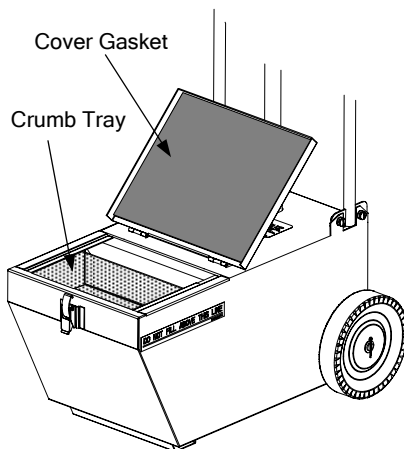

**⚠ DANGER**

Before each use inspect the cover to ensure the cover gasket is present and properly placed. **DO NOT** use the disposal unit if this gasket is damaged or missing.

3. *Slowly* open the drain valve. Regulate flow with the drain valve to prevent splashing.

**⚠ DANGER**

**DO NOT OVERFILL!** Do not fill the reservoir above the fill lines on the sides of the reservoir. Moving the SDU with an overfilled reservoir may result in spills and injury to personnel who come in contact with the spilled shortening.

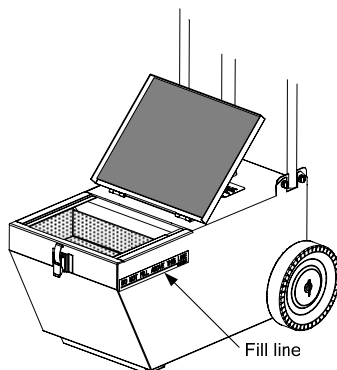

4. Carefully withdraw the unit far enough to allow the cover to be closed. Latch the cover in the closed position. Using the handle, carefully tip the unit back slightly for ease of handling and roll the unit to the disposal site.

**⚠ WARNING**

**DO NOT** use the pump or discharge piping assembly as a handle!

**⚠ DANGER**

To minimize the potential for burns, shortening/oil must always be allowed to cool below 100°F (38°C) before draining into the SDU and transporting to the disposal area. However, **DO NOT** allow shortening to solidify in the SDU.

The unit is designed to be moved, when properly filled, at an average walking pace on a flat surface. *Care must be taken at all times when moving hot shortening or oil. Rough terrain or sudden stops and starts may cause the contents of the reservoir to spill or splash out of the reservoir, possibly causing serious injury to personnel. Always ensure that the cover is latched shut when moving the unit.*

5. At the disposal site, lift the pump assembly lock pin and rotate the discharge pipe as necessary to position the discharge nipple over the opening of the disposal container. Release the lock pin to secure the pump assembly in position. Turn the pump handle clockwise. The pump should start discharging oil after a few turns. Continue turning the handle until the MSDU reservoir is empty. **NOTE:** The pump is *NOT* self-priming. If it has not been used for several days, it may have lost its prime and may need to be re-primed in accordance with Step 3 of Section 2.2.

6. On BKSDU units, the built-in heater may be connected to a grounded 120VAC or 240VAC receptacle to prevent shortening from solidifying in the tank when immediate transfer to a disposal container is not possible.

## 2.4 Cleaning

Clean the crumb screen with a solution of detergent and water. Clean the *exterior surfaces* of the SDU with a soft cloth and a solution of detergent and water. It is not necessary to clean the interior of the reservoir, but if desired it may be wiped down with clean paper towels to remove excess residual shortening.

### WARNING

**DO NOT clean the interior of the reservoir with water or detergent. Introduction of water or detergent into the unit will permanently damage the pump.**

## 3. SERVICE PROCEDURES

### 3.1 Introduction

Other than routine cleaning and the replacement of worn suction tube O-rings, the SDU is maintenance free. After long use, the pump vanes and pump shaft seal may require replacement due to wear. Frymaster recommends worn pump vanes and/or pump shaft seals be replaced by an FASC, but store personnel may perform these service actions without voiding the warranty.

### 3.2 Replacing Worn or Damaged O-Rings

If pump efficiency degrades, it is likely that the O-rings on the suction tube are worn or damaged. To replace the O-rings, follow the steps below.

1. Lift the pump assembly straight up and out of the handle assembly.
2. Remove the worn or damaged O-rings from the grooves at the bottom of the suction tube and replace with new O-rings. Apply *Accrolube with Teflon* grease or equivalent to bottom 2 inches of the suction tube.
3. Insert the suction tube through the tube bracket in the handle and into the receiver on top of the reservoir. Push down on the pump assembly to make sure the suction tube is fully seated.

### 3.3 Replacing Worn Pump Vanes and/or Pump Shaft Seal

Depending upon the amount of use, the vanes in the pump assembly will eventually wear, reducing the efficiency of the pump. The pump shaft seal can also become worn and start to leak. A kit for replacing the vanes and the seal is available. The pump shaft seal can also be purchased as a separate item. To replace the pump vanes, and/or the pump shaft seal, follow the steps below (refer also to the illustration on Page 6).

1. Loosen the setscrew securing the pump handle to the pump shaft and slip the handle off the shaft. If unit is a BKSDU remove the eight screws that secure the pump cover in place and remove the cover.



2. Remove the five screws securing the front cover and remove the cover.

If replacing the pump shaft seal only, remove the old seal and install the replacement as shown in the illustration below, then go to Step 5.

If replacing the pump vanes, go to Step 3.

3. Grasp the pump shaft and carefully pull the rotor assembly straight out of the pump housing far enough to expose the vanes. **IMPORTANT:** The vanes are spring-loaded. Use one hand to hold the vanes while pulling the rotor assembly the rest of the way out of the housing. Carefully release the vanes and discard the worn vanes, springs, and rods.

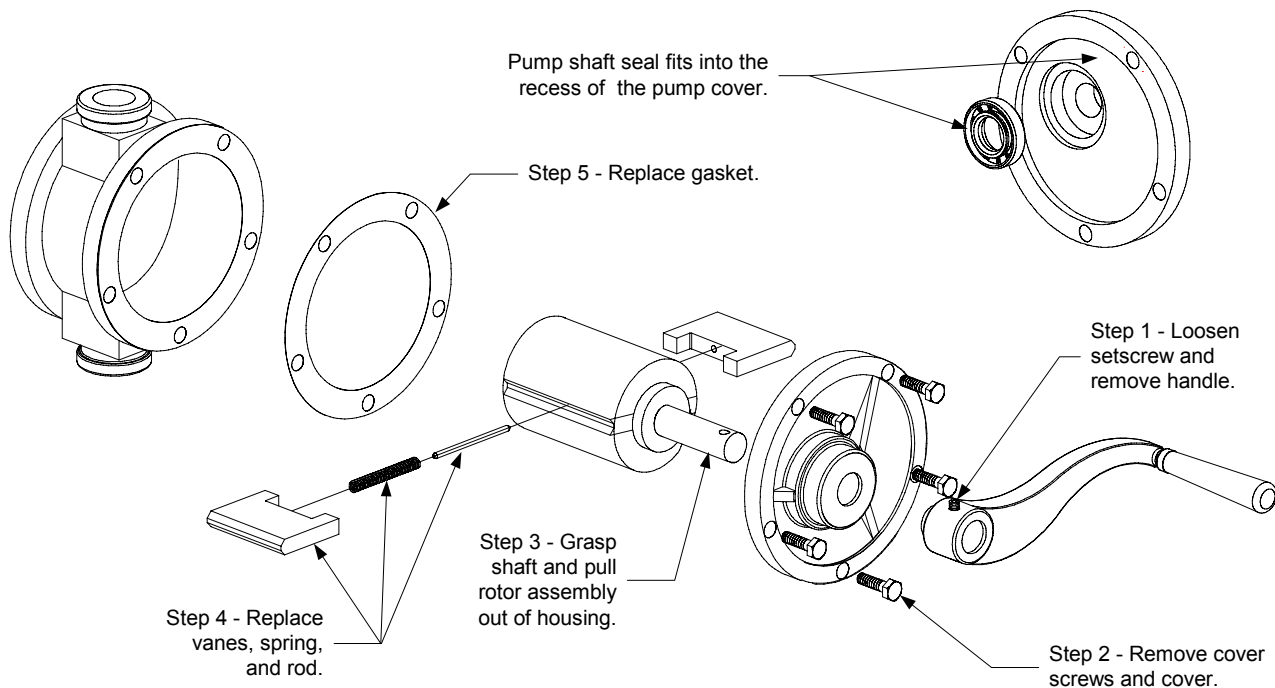

4. Assemble the replacement vanes, spring and rod into the rotor assembly. Compress the vane spring and carefully insert the rotor assembly back into the pump housing.
5. Position the replacement gasket on the pump body, slip the cover over the shaft, and align the pins in the cover with the holes in the pump housing. Reinstall the five screws removed in Step 2 and tighten securely (torque to approximately 60 inch-pounds).
6. Slip the pump handle back onto the shaft and align the screw hole in the handle with the screw hole in the shaft. Tighten the setscrew loosened in Step 1 securely.

# 4. PARTS LIST

**NOTE: See Page 6 for BKSDU pump assembly components.**

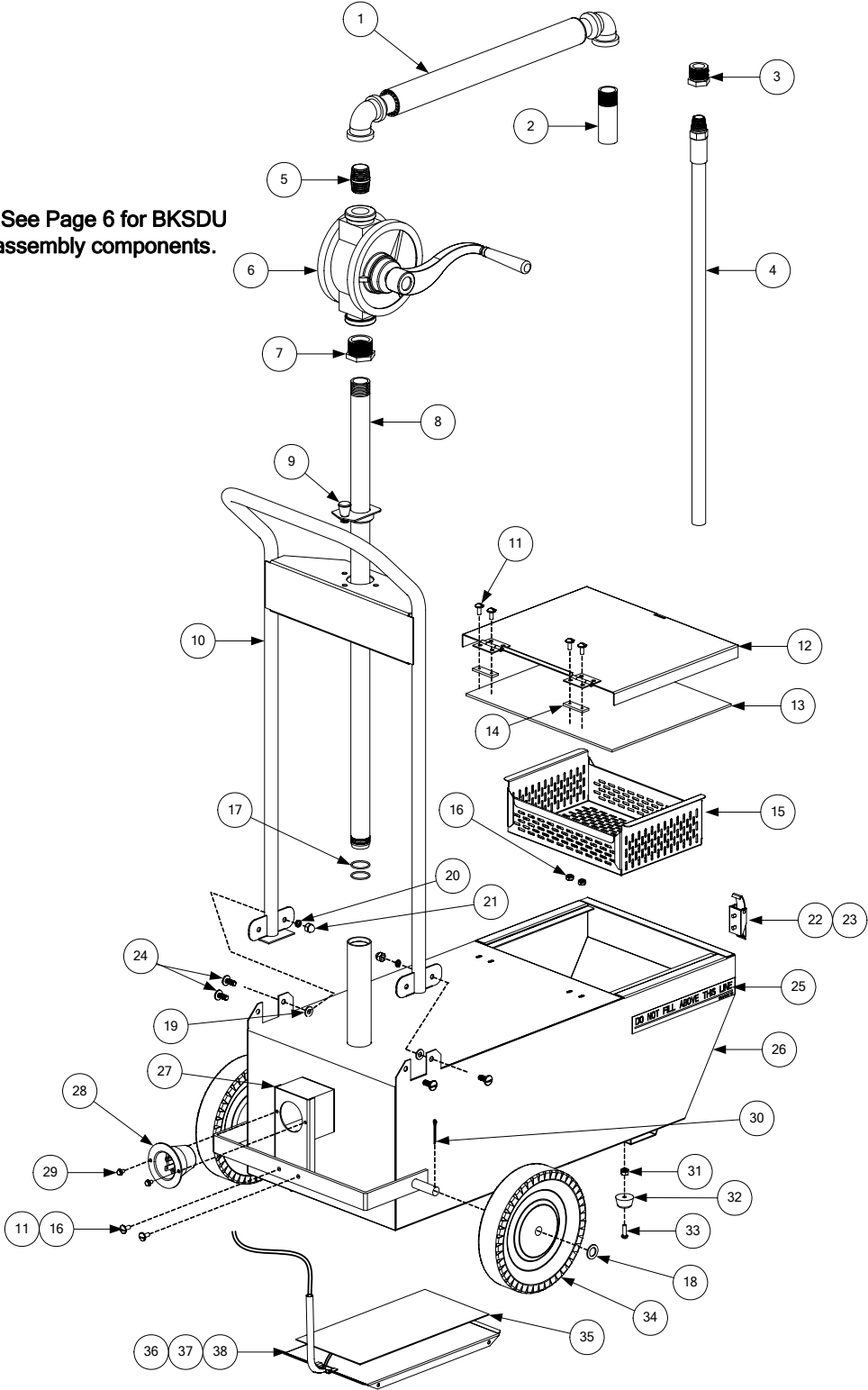

| Item | Part #     | Component   |
|------|------------|---|
| 1    |            | Pipe Assembly, Discharge  |
|      | 823-4600   | Standard <b>(includes Item 2) (use 823-4617 for BKSDU)</b>                              |
|      | 823-4598   | For use with Item 4 <b>(Hose Discharge) (includes Item 3)</b>                           |
| 2    | 813-0115   | Nipple, 3/4-inch x 3-inch Toe   |
| 3    | 813-0031   | Bushing, 3/4-inch x 1/2-inch  |
| 4    | 810-1845   | Hose, 24-inch Discharge <b>(Optional) (use 810-2797 for 48-inch hose)</b>               |
| 5    | 813-0109   | Nipple, 3/4-inch x Close  |
| 6    | 810-0784   | Pump <b>(includes handle 810-0657, which may be ordered separately)</b>                 |
| *    | 826-1053   | Kit, Pump Repair <b>(includes two vanes, one spring, one rod, one gasket.)</b>          |
| *    | 816-0401   | Seal, Pump Shaft  |
| 7    | 813-0032   | Bushing 1-inch x 3/4-inch Hex   |
| 8    | 823-4581   | Pipe Assembly, Suction  |
| 9    | 810-0777   | Pin, Plunger  |
| 10   |            | Handle Assembly   |
|      | 823-2038   | SDU50 and BKSDU   |
|      | 823-2421   | SDU90   |
| 11   | 809-0119   | Screw, 10-32 x 1/2-inch Slotted Head  |
| 12   |            | Cover and Hinge Assembly  |
|      | 823-1683SP | SDU50 and BKSDU <b>(does not include gasket (Item 13))</b>                              |
|      | 823-2422SP | SDU90 <b>(does not include gasket (Item 13))</b>  |
| 13   |            | Gasket, Cover <b>(attach with 3M 1300L adhesive or equivalent)</b>                      |
|      | 816-0134   | SDU50 and BKSDU   |
|      | 816-0264   | SDU90   |
| 14   | 816-0133   | Gasket, Cover Hinge   |
| 15   |            | Screen, Crumb   |
|      | 824-0438   | SDU50 and BKSDU   |
|      | 824-0615   | SDU90   |
| 16   | 826-1376   | Nut, 10-32 Keps Hex (Pkg. of 10)  |
| 17   | 816-0132   | O-ring, Suction Pipe Assembly <b>(2 required)</b>                                       |
| 18   | 809-0200   | Washer, Wheel 1/2" SAE  |
| 19   | 809-0193   | Washer, 1/4-inch Nylon Flat   |
| 20   | 809-0191   | Lock Washer, 1/4-inch   |
| 21   | 809-0047   | Nut, 1/4-20 S/S Cap   |
| 22   | 810-0742   | Latch, Tank Cover   |
| 23   | 809-0359   | Screw, #8 x 1/4-inch  |
| 24   | 809-1001   | Screw, 1/4-20 x 1/2" Slotted Head   |
| 25   | 802-0227   | Label, Fill Line  |
| 26   |            | Tank and Axle Assembly  |
|      | 823-4580SP | SDU50 and BKSDU   |
|      | 826-2103   | SDU50 Retrofit Kit for SDU's manufactured before Jan. 2004.                             |
|      | 823-4583   | SDU90 <b>If replacing tank manufactured pre-Jan.2004, 823-4581 will also be needed.</b> |
| 27   | 823-1911   | Housing, 120VAC Receptacle <b>(BKSDU only) (use 823-5060 for 240VAC)</b>                |
| 28   | 807-1219   | Receptacle, 120V 3-wire <b>(BKSDU only) (use 807-4108 for 240VAC)</b>                   |
| 29   | 809-0266   | Screw, #10 x 1/2-inch Phillips Truss Head <b>(use 809-0396 for 240VAC Receptacle)</b>   |
| 30   | 810-0783   | Cotter Pin, Wheel   |
| 31   | 809-0054   | Nut, 10-32 Elastic Lock <b>(BKSDU only)</b>   |
| 32   | 814-0051   | Bumper, Rubber <b>(BKSDU only)</b>  |
| 33   | 809-0122   | Screw, 10-32 x 5/8-inch Slotted Round Head <b>(BKSDU only)</b>                          |
| 34   | 810-1112   | Wheel, 7-inch x 1 1/2-inch  |
| 35   | 807-1577   | Heater, 120V 50W 5" x 10" <b>(BKSDU only)</b>   |
| *    | 807-1224   | Cord, Power – 120VAC <b>(BKSDU only)**</b> (use 106-4697 for 240VAC)                    |
| 36   | 823-1915   | Shield Heater <b>(BKSDU only)</b>   |
| 37   | 809-0104   | Screw, 8-32 x 1/2-inch Slotted Truss Head <b>(BKSDU only)</b>                           |
| 38   | 809-0247   | Nut, 8-32 Keps Hex <b>(BKSDU only)</b>  |
| *    | 815-0661   | Adhesive, 3M 1300L  |

\* Not illustrated.

\*\* **CAUTION:** Risk of fire and electric shock. Replace only with manufacturer's cord set, part No. 8071224 for 120V.

**NOTE:** The BKSDU pump assembly is identical to the SDU 50/SDU 90 pump assembly except for the addition of the pump cover and insulation and the modified discharge pipe assembly.

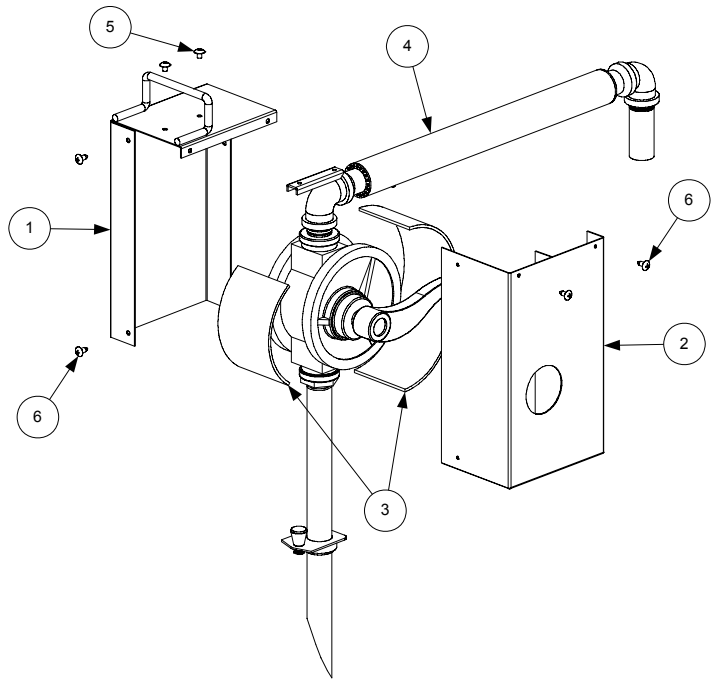

| ITEM | PART #   | COMPONENT   |
|------|----------|---|
| 1    | 823-1847 | Cover and Handle Assembly, BKSDU                  |
| 2    | 900-4429 | Box, BKSDU Pump                                   |
| 3    | 811-0861 | Insulation, 3-inch X 50-foot Adhesive-Backed Foam |
| 4    | 823-4617 | Pipe Assembly, BKSDU Discharge                    |
| 5    | 809-0477 | Screw, #10 X ¼-inch Philips Truss Head            |
| 6    | 809-0266 | Screw, #10 X ½-inch Philips Truss Head            |



Enodis®  
One Company, Countless Solutions

Frymaster, L.L.C., 8700 Line Avenue, PO Box 51000, Shreveport, Louisiana 71135-1000  
Shipping Address: 8700 Line Avenue, Shreveport, Louisiana 71106

TEL 1-318-865-1711 FAX (Parts) 1-318-688-2200 FAX (Tech Support) 1-318-219-7135