



## ***Owner's Manual***

---

***Model 1812***  
***Telephone Intercom Systems***

DoorKing, Inc.  
120 Glasgow Avenue  
Inglewood, California 90301  
U.S.A.  
Phone: 310-645-0023  
Fax: 310-641-1586  
[www.doorking.com](http://www.doorking.com)



**Use this manual with the following models only.**

All 1812 Telephone Intercom Systems with circuit board 1871-010 REV S or higher.

DoorKing, Inc. reserves the right to make changes in the products described in this manual without notice and without obligation of DoorKing, Inc. to notify any persons of any such revisions or changes. Additionally, DoorKing, Inc. makes no representations or warranties with respect to this manual. This manual is copyrighted, all rights reserved. No portion of this manual may be copied, reproduced, translated, or reduced to any electronic medium without prior written consent from DoorKing, Inc.

# TABLE OF CONTENTS

## Preface

Important Notices.....	6
General Information.....	7
Features .....	8

## Section 1 – Installation & Wiring

<b>Installation Guidelines .....</b>	<b>9</b>
1.1 Surface Mount Units.....	10
Surface Mount Dimensions .....	11
1.2 Flush Mount Units.....	12
Flush Mount Dimensions .....	13
1.3 Wall Mount Units .....	14
Wall Mount Dimensions.....	15
1.3 By-Pass Switch Installation and Wiring.....	16
1.4 Telephone Line Wiring – Single Unit .....	17
1.5 Telephone Line Wiring – Multiple Units.....	18
1.6 Intercom Mode Wiring – Single Unit.....	19
1.7 Intercom Mode Wiring – Multiple Units.....	20
1.8 Main Terminal Description.....	21
1.9 Front Panel Terminal Description.....	22

## Section 2 – Programming

<b>2.1 Programming Information</b>	
2.1.1 Programming from the Keypad .....	23
2.1.2 Programming with a Personal Computer .....	23
2.1.3 Programming with a Touch-Tone Telephone .....	23
<b>2.2 PC Programming Setup</b>	
2.2.1 Master Code.....	24
2.2.2 System Setup Code .....	24
<b>2.3 General Programming Information</b>	
2.3.1 Relay Strike Time.....	25
2.3.2 Tone Open Numbers.....	25
2.3.3 Phone / Intercom Mode.....	26
2.3.4 Talk Time.....	26
2.3.5 Answer Incoming Call.....	26
2.3.6 Number of Rings to Answer .....	27
<b>2.4 Time Functions Programming</b>	
2.4.1 Time Clock Programming.....	28
2.4.2 Do Not Disturb Time Zone Programming.....	28
2.4.3 Automatic Relay Activation Time Zones.....	29
2.4.4 Entry Code Time Zones .....	29
2.4.5 Call Forward Time Zone.....	30
2.4.6 Flash Code Programming .....	30
<b>2.5 Programming Dial-Out Functions</b>	
2.5.1 Call Forward Programming .....	31
2.5.2 Call Forward On / Off .....	31
2.5.3 Preprogrammed Phone Numbers .....	31
<b>2.6 Entry Code Programming</b>	
2.6.1 Four-Digit Entry Code Programming.....	32
2.6.2 Delete Four-Digit Entry Codes .....	32
2.6.3 Delete All Four-Digit Entry Codes .....	32

### **Section 3 – Adjustments**

Speaker Volume .....	33
Feedback 1 .....	33
Feedback 2 .....	33
Master Code Switch .....	33
Circuit Board Adjustment Locations .....	34

### **Section 4 – Operating Instructions**

4.1	Calling the Resident .....	35
4.2	Call Waiting .....	35
4.3	Preprogrammed Phone Numbers .....	36
4.4	Entry Codes .....	36
<b>Resident Operation Instructions</b>		
4.5	Call Forwarding Enable / Disable .....	37
4.6	Call Forward Time Zone Enable / Disable .....	37
4.7	Do Not Disturb Enable / Disable .....	37
4.8	Entry Code Time Zone Enable / Disable .....	38
4.9	Auto Relay Time Zones Enable / Disable .....	38
4.10	Auto Answer Enable / Disable .....	38
4.11	Relay Activation Check .....	39
4.12	Remote Programming .....	39
4.13	Remote Relay Activation .....	39
4.14	Switch Input Operation .....	40

### **Section 5 – Maintenance and Trouble Shooting**

5.1	<b>Trouble Shooting</b>	
	Isolating Noise Problems .....	41
	Trouble Shooting Chart .....	43
5.2	Accessories .....	45
5.3	Tables .....	46
	Entry Code Log Sheet .....	47

## **IMPORTANT NOTICE**

### ***FCC - UNITED STATES***

This equipment has been tested and found to comply with the limits for a class A digital device, pursuant to Part 15 of the FCC Rules and Regulations. These limits are designed to provide reasonable protection against harmful interference when the equipment is operated in a commercial environment. This equipment generates, uses, and can radiate radio frequency energy and, if not installed and used in accordance with the instruction manual, may cause harmful interference to radio communications. Operation of this equipment in a residential area is likely to cause harmful interference in which case the user will be required to correct the interference at his own expense.

FCC Registration Number: **DUF6VT-12874-OT-T**

### ***DOC - CANADA***

The Canadian Department of Communications label identifies certified equipment. This certification means that the equipment meets certain telecommunications network protective, operational, and safety requirements. The Department does not guarantee the equipment will operate to the users satisfaction.

Before installing this equipment, users should ensure that it is permissible to be connected to the facilities of the local telecommunications company. The equipment must also be installed using an acceptable means of connection. The customer should be aware that compliance with the above conditions may not prevent degradation of service in some situations.

Repairs to certified equipment should be made by an authorized Canadian maintenance facility designated by the supplier. Any repairs or alterations made by the user to this equipment, or equipment malfunctions, may give the telecommunications company cause to request the user to disconnect the equipment.

Users should ensure, for their own protection, that the electrical ground connections of the power utility, telephone lines, and internal metallic water pipe system, if present, are connected together. This precaution may be particularly important in rural areas.

**CAUTION:** Users should not attempt to make such connections themselves, but should contact the appropriate electric inspection authority, or electrician, as appropriate.

DOC Registration Number: **1736 4507 A**

### ***Notice:***

The Load Number (LN) assigned to each terminal device denotes the percentage of the total load to be connected to a telephone loop which is used by the device, to prevent overloading. The termination on a loop may consist of any combination of devices subject only to the requirement that the sum of the load numbers of all the devices does not exceed 100.

### ***Notice:***

DoorKing does not provide a power transformer on units sold into Canada. Use only transformers that are CSA listed to power the telephone entry system. 1802, 1803, 1808, 1810, 1814, 1815, 1818 and all "P" series systems require a 16.5-volt, 20 VA transformer. The models 1816 and 1817 require a 16.5-volt, 40 VA transformer. The model 1812 requires a 24-volt, 20 VA transformer.

### ***Listing:***

This product has been tested to and found to be in compliance with the U.L 294 Safety Standard by Intertek Testing Services NA Inc. (a Nationally Recognized Testing Laboratory) and is ETL listed.

## IMPORTANT INFORMATION

- Prior to beginning the installation of the telephone entry system, we suggest that you become familiar with the instructions, illustrations, and wiring guidelines in this manual. This will help insure that your installation is performed in an efficient and professional manner.
- The proper installation of the telephone entry panel is an extremely important and integral part of the overall access control system. Check all local building ordinances and building codes prior to installing this system. Be sure your installation is in compliance with local codes.
- When used to control a door or pedestrian gate, try to locate the telephone entry system as near as possible to the entry point. The unit should be mounted on a rigid wall to prevent excessive shock and vibration from closing doors or gates. Continuous vibration and shock from slamming doors or spring-loaded pedestrian gates will damage the circuit board. **Under no circumstances should the unit be mounted directly to a moving door or gate.**
- **ADA mounting requirements for door control.** The requirements below apply only when the telephone entry system is being used to control entry through a public door only. If this system is used to control entry through a vehicular gate or private entrance, the dimensions noted below do not apply.
  1. If the clear floor space allows only forward approach to the system, the maximum high forward reach allowed is 48 inches above grade to the top of the keypad.
  2. If the high forward reach to the system is over an obstruction of greater than 20 inches but less than 25 inches, the maximum high forward reach allowed is 44 inches above grade to the top of the keypad.
  3. If the clear floor space allows parallel approach by a person in a wheelchair, the maximum high side reach shall be 54 inches above grade to the top of the keypad.
  4. If the high side reach is over an obstruction of 24 inches or less, the maximum high side reach allowed is 46 inches above grade to the top of the keypad.
- **When used to control a vehicular gate with an automatic gate operator, the telephone entry system must be mounted a minimum of ten (10) feet away from the gate and gate operator, or in such a way that a person cannot operate the entry system and/or touch the gate or gate operator at the same time.**
- Be sure that the system is installed so that it is not directly in the traffic lane. Goose neck mounting post and kiosks work well for these type systems. When planning where to locate the system, take into consideration traffic lane layouts, turn around lanes for rejected access, conduit runs, power availability, etc.
- Environmental factors must also be taken into account. Surface mount units are designed for direct outdoor installations, however it is preferable to protect them from direct exposure to driven rain or snow whenever possible. Flush mount units must be protected from direct exposure to the elements.
- This telephone entry system contains a number of static sensitive components that can be damaged or destroyed by static discharges during installation or use. Discharge any static prior to removing the circuit board from the lobby panel by touching a proper ground device.
- **Instruct the end user to read and follow these instructions. Instruct the end user to never let children play with or operate any access control device. This Owner's Manual is the property of the end user and must be left with them when installation is complete.**

## FEATURES

- Unique telephone communication system allows homeowners to use their telephone as an intercom to speak to a guest at a front door or gate, and to control access to their property.
- Unit can be programmed from the homeowners PC with DoorKing's Windows compatible Auto-Programming software.
- Unit connects directly to the homeowners existing telephone line. No additional monthly expense for a second telephone line.
- Built in call waiting assures that incoming calls or guest calls are not missed.
- Two internal relays allow the system to control a main entry gate plus a pedestrian access gate.
- Built-in clock / calendar provides the following time related functions:
  1. Do-not-disturb time zone.
  2. Four hold-open time zones.
  3. Entry code time zones.
  4. Call forwarding time zone.
  5. Flash entry code.
- Unit can be programmed to work with PBX and KSU phone systems.
- Optional slave keypad can be added for remote entry code activation of door or gate. Order part number 1812-082.



## SECTION 1 - INSTALLATION

- Installation of the telephone intercom system involves the installation and wiring of the Entry System By-pass Switch and the installation and wiring of the 1812 unit itself.
- Do not use thinly insulated brown-jacketed telephone wire (the type found in the walls of a house) for any phone line wiring. These wires must be of the proper gauge and must be rated for direct underground burial. A clear, noise free system is directly related to the quality of the telephone wire used. Do not run telephone lines and high voltage lines in the same conduit. Separate high voltage and telephone line conduits by at least six (6) inches. Be sure that all phone wires are twisted.

TELEPHONE LINE WIRING	
WIRE SIZE	MAX DISTANCE IN FEET
24 AWG	800
22 AWG	1600
20 AWG	2200
18 AWG	3600

- It is highly recommended that telephone line surge suppressers (DoorKing p/n 1877-010) be installed on both the phone in and phone out lines to help protect the system from power surges.
- Use the supplied power transformer, 24 VAC, 20 VA (or U.L. listed equivalent) to power the telephone intercom system. Do not power any other devices (electric strikes, magnetic locks, etc.) from this power transformer. For wire runs up to 100 feet, use 18 AWG wire. For wire runs up to 200 feet, use 16 AWG wire. **Power runs are susceptible to noise and hum pick-up, therefore it is preferable that you keep power runs as short as possible.**

POWER WIRING	
WIRE SIZE	MAX DISTANCE IN FEET
18 AWG	100
16 AWG	200

- It is highly recommended that a low voltage surge suppresser (DoorKing p/n 1878-010) be installed to help protect the telephone entry system from power surges.
- Proper grounding and the use of surge suppressers can significantly reduce the chance of component failure because of static charges or surges. To be effective, ground connections should be made with a minimum 12 AWG wire to a ground point within 10 feet of the telephone intercom system. The ground point must be at an electrical panel, a metallic cold water pipe that runs in the earth, or a grounding rod driven at least 10 feet into the soil. **A gooseneck mounting post anchored in concrete does not make a good ground.**

## 1.1 SURFACE MOUNT UNITS

Surface mount units can be mounted directly to a wall or pilaster or post mounted using a DoorKing mounting post (p/n 1200-045 or 1200-046). Be sure that the unit is securely mounted and is not subject to continuous vibration from closing doors or gates.



**If used to control a vehicular gate with an automatic gate operator, the telephone entry system must be mounted a minimum of ten (10) feet away from the gate and gate operator, or in such a way that a person cannot operate the entry system and/or touch the gate or gate operator at the same time.**

1. Open the cabinet of the 1812 and carefully disconnect the front panel terminal connector and the keypad connector. The front panel terminal connector is located in the lower right hand corner. Do not disconnect the wires from this connector. The entire connector will come off the board by gently pulling it straight out.
2. Remove four (4) 6-32 x 1/2 round head screws from each corner of the control board.
3. Remove the control board from the housing. CAUTION: The control board contains static sensitive components. Discharge any static electricity from your hands by touching a proper ground device before removing the control board.
4. Mount the 1812 housing assembly. Make any conduit connections at this time. Be sure that the mounting screws do not protrude into the cabinet where they could cause a short.
5. Route wiring into the housing assembly at this time. DO NOT APPLY POWER.
6. Clean out the back box. Be sure that all dirt, metal or wood debris is removed from the back box.
7. Remove the main terminal wiring connector from the control board by gently pulling it straight up. This will make wiring to the main terminal easier.
8. Install the control board into the back box. Secure the control board with the four (4) 6-32 x 1/2 screws removed in step 2. CAUTION: The control board contains static sensitive components. Discharge any static electricity from your hands by touching a proper ground device before installing the control board.
9. Plug the front panel connector onto the control board pins in the lower right hand corner. The red wire goes to the left.
10. Plug the keypad connector onto the circuit board plug. The cable points down.
11. After pre-wiring the main terminal control board connector (see wiring instructions), carefully re-install it onto the control board main terminal pins.

## Surface Mount Dimensions

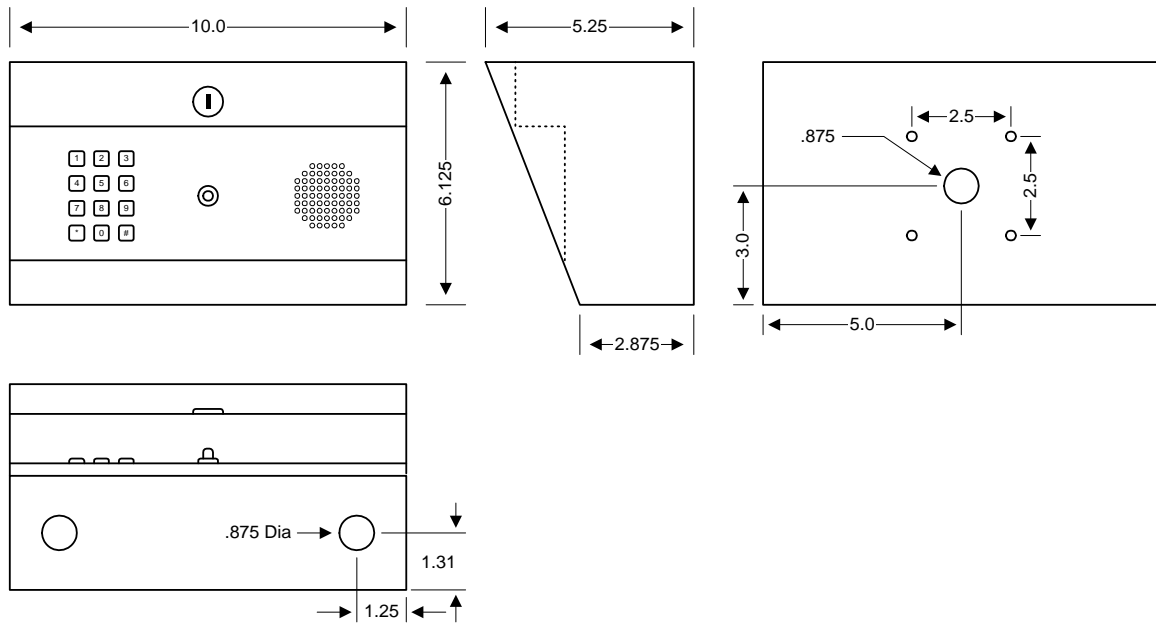

## 1.2 FLUSH MOUNT UNITS

Flush mount units are designed to be mounted directly into a wall or column. Be sure the unit is mounted securely and is not subject to vibration from closing doors or gates.



**If used to control a vehicular gate with an automatic gate operator, the telephone entry system must be mounted a minimum of ten (10) feet away from the gate and gate operator, or in such a way that a person cannot operate the entry system and/or touch the gate or gate operator at the same time.**

The rough-in box should be installed prior to installing the flush mount unit. Be sure that the rough-in box is securely mounted and is not subject to continuous vibration from closing doors or gates.

1. Be sure that the rough-in box is securely mounted into the wall or pilaster. Route any pre-wiring into the rough-in box at this time.
2. Open the cabinet of the 1812 and carefully disconnect the front panel terminal connector and the keypad connector. The front panel terminal connector is located in the lower right hand corner. Do not disconnect the wires from this connector. The entire connector will come off the board by gently pulling it straight out.
3. Remove four (4) 6-32 a 1/2 round head screws from each corner of the control board.
4. Remove the control board from the housing. CAUTION: The control board contains static sensitive components. Discharge any static electricity from your hands by touching a proper ground device before removing the control board.
5. Mount the 1812 housing assembly into the rough-in box using four (4) 6-32 x 1/2 screws supplied. Mounting holes are located in each corner of the back box and will align with PEM nuts in the rough-in box.
6. Make conduit connections and route wiring into the housing assembly at this time. DO NOT APPLY POWER.
7. Clean out the back box. Be sure that all dirt, metal or wood debris is removed from the back box.
8. Remove the main terminal wiring connector from the control board by gently pulling it straight up. This will make wiring to the main terminal easier.
9. Install the control board into the back box. Secure the control board with the four (4) 6-32 x 1/2 screws removed in step 2. CAUTION: The control board contains static sensitive components. Discharge any static electricity from your hands by touching a proper ground device before installing the control board.1
10. Plug the front panel connector onto the control board pins in the lower right hand corner. The red wire goes to the left.1
11. Plug the keypad connector onto the circuit board plug. The cable points down.1
12. After pre-wiring the main terminal control board connector (see wiring instructions), carefully re-install it onto the control board main terminal pins.

## Rough-in Box Dimensions

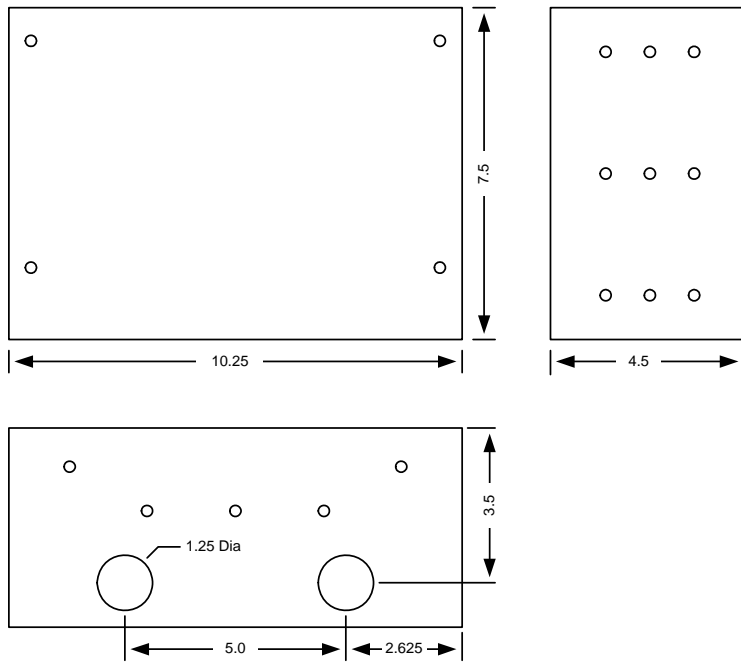

## Flush Mount Dimensions

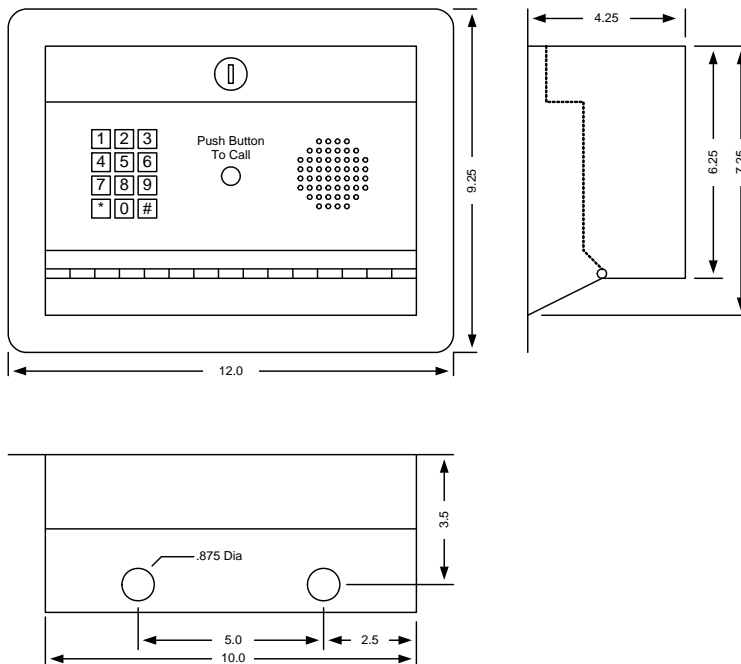

## 1.3 WALL MOUNT UNITS

Wall mount units can be mounted directly to a wall or pilaster or post mounted using a DoorKing mounting post (p/n 1200-045 or 1200-046). Be sure that the unit is securely mounted and is not subject to continuous vibration from closing doors or gates.



**If used to control a vehicular gate with an automatic gate operator, the telephone entry system must be mounted a minimum of ten (10) feet away from the gate and gate operator, or in such a way that a person cannot operate the entry system and/or touch the gate or gate operator at the same time.**

The rough-in box should be installed prior to installing the wall mount unit. Be sure that the rough-in box is securely mounted and is not subject to continuous vibration from closing doors or gates.

1. Be sure that the rough-in box is securely mounted into the wall or pilaster. Route any pre-wiring into the rough-in box at this time.
2. Open the cabinet of the 1812 and carefully disconnect the front panel terminal connector and the keypad connector. The front panel terminal connector is located in the lower right hand corner. Do not disconnect the wires from this connector. The entire connector will come off the board by gently pulling it straight out.
3. Remove four (4) 6-32 a 1/2 round head screws from each corner of the control board.
4. Remove the control board from the housing. CAUTION: The control board contains static sensitive components. Discharge any static electricity from your hands by touching a proper ground device before removing the control board.
5. Mount the 1812 housing assembly into the rough-in box using four (4) 6-32 x 1/2 screws supplied. Mounting holes are located in each corner of the back box and will align with PEM nuts in the rough-in box.
6. Make conduit connections and route wiring into the housing assembly at this time. DO NOT APPLY POWER.
7. Clean out the back box. Be sure that all dirt, metal or wood debris is removed from the back box.
8. Remove the main terminal wiring connector from the control board by gently pulling it straight up. This will make wiring to the main terminal easier.
9. Install the control board into the back box. Secure the control board with the four (4) 6-32 x 1/2 screws removed in step 2. CAUTION: The control board contains static sensitive components. Discharge any static electricity from your hands by touching a proper ground device before installing the control board.1
10. Plug the front panel connector onto the control board pins in the lower right hand corner. The red wire goes to the left.1
11. Plug the keypad connector onto the circuit board plug. The cable points down.1
12. After pre-wiring the main terminal control board connector (see wiring instructions), carefully re-install it onto the control board main terminal pins.

**Wall Mount Dimensions**

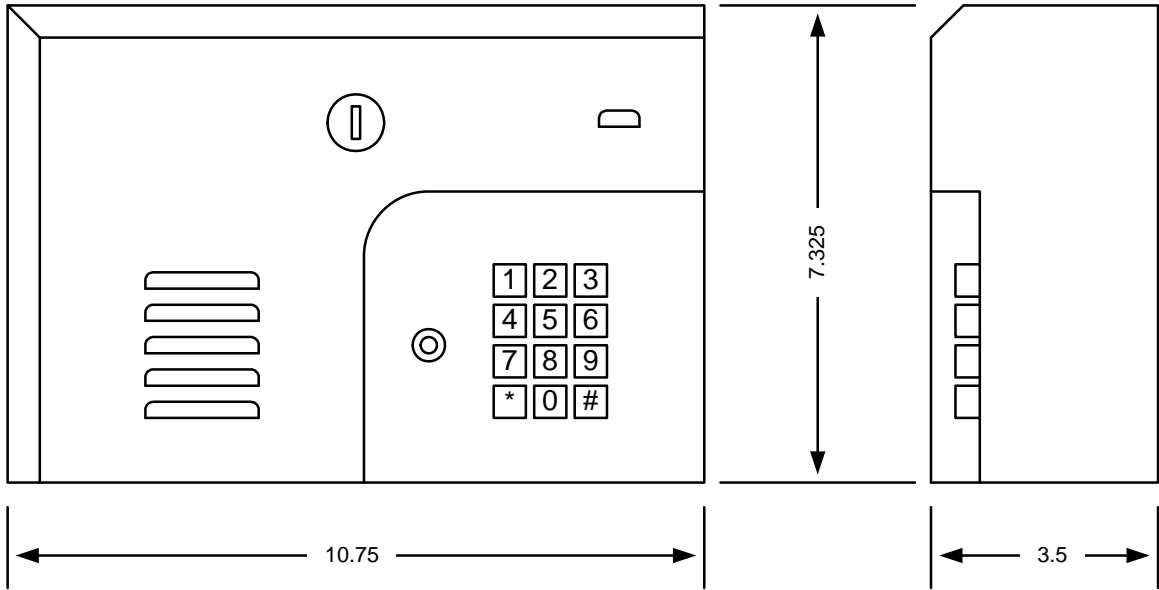

## 1.4 BY-PASS SWITCH INSTALLATION AND WIRING

- The by-pass switch should be installed in a location where it is accessible by the homeowner.
- The by-pass switch must be protected from the weather. It is not designed for direct exposure to rain, snow or other elements. If you are installing the by-pass switch outside of the home, use a NEMA rated rain resistant enclosure to mount the by-pass switch in.
- Pay special attention when connecting the by-pass switch to the Central Office (C.O.) demarcation device. The by-pass switch must be wired so that it is on the homeowner's side of the demarcation device and not the C.O. side.
- Pay special attention to the type of wire used when connecting the phone line wires. Refer to the wire size chart on page 9 for proper wire size. Use only twisted pair telephone wire that is rated for outdoor use and direct burial. Using thin jacketed telephone wire that is designed for indoor use will result in noise and hum on the homeowners telephone.

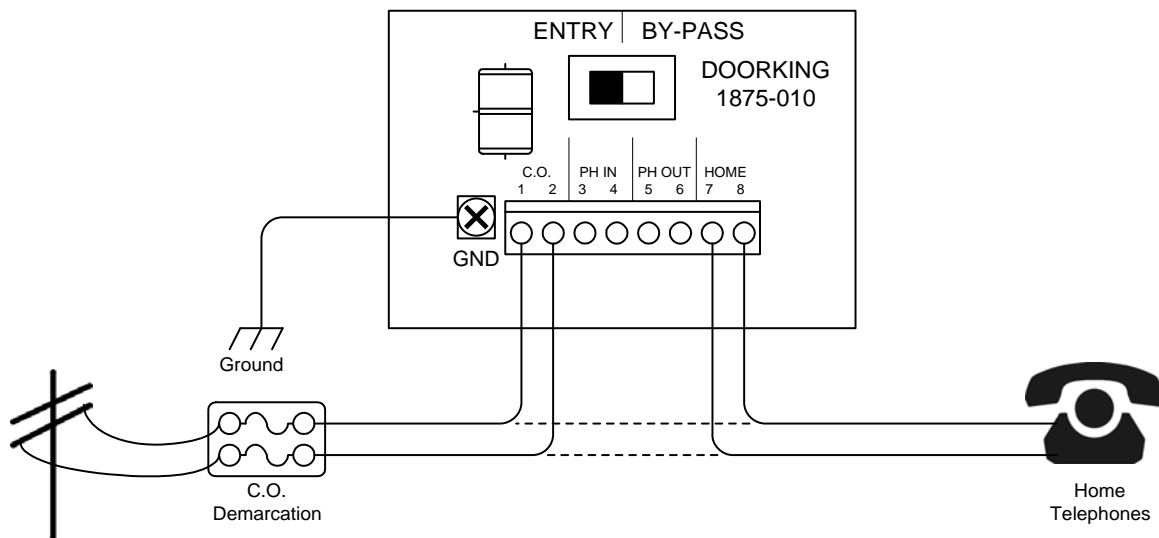

1. Mount the by-pass switch in a location that is easily accessible by the homeowner. If installed outdoors, be sure to protect the by-pass switch from direct exposure to rain, snow and other elements.
2. Locate the telephone company demarcation device. **IMPORTANT! Identify the wires that connect to the homeowner's telephones.** Disconnect these wires from the demarcation device and connect them to terminals 7 and 8 on the by-pass switch.
3. Connect a twisted-pair telephone wire to terminals 1 and 2 on the by-pass switch. Connect the other end of these wires to the telephone company demarcation device where you removed the wires in step 2.
4. Place the by-pass switch in the "BY-PASS" position until the 1812 unit is installed. Test the homeowner's telephone. They should have dial tone while the switch is in the BY-PASS position.
5. Be sure to ground the by-pass switch using #12 AWG wire.



## 1.5 TELEPHONE LINE WIRING – SINGLE UNIT

If any alarm systems are installed on the phone line, be sure that the alarm interface precedes the 1812 by-pass switch interface.

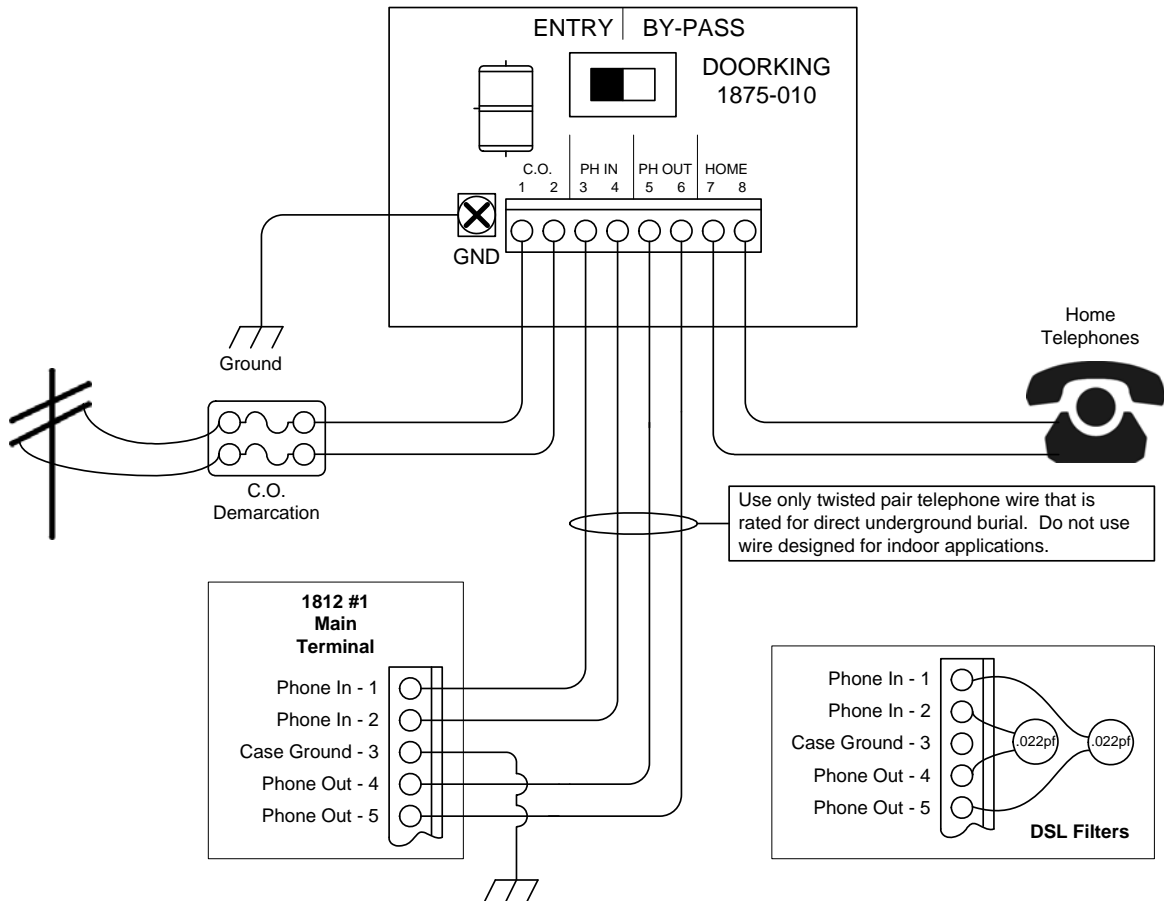

1. Connect PHONE IN wires from the BY-PASS switch to 1812 main terminals 1 and 2.
2. Connect PHONE OUT wires from the BY-PASS switch to 1812 main terminals 4 and 5.
3. Connect a ground wire to terminal 3.
4. Check for polarity on the phone "IN" wires, terminals 1 and 2. Terminal 2 must be positive with respect to terminal 1. Set a VOM meter to measure DC volts. Place the positive lead on terminal 2 and the negative lead on terminal 1. If the meter shows a positive voltage - OK. If the meter shows a negative voltage (needle moves off scale to the left), reverse the wires on terminals 1 and 2.
5. Surge protection is recommended on both the phone in and phone out lines. Use DoorKing phone line surge suppressers (p/n 1877-010) or equivalent.

**DSL Filters:** The 1812 has been tested with several different types of DSL services. In most of these applications, the DSL service did not interfere with the performance or operation of the 1812 system. However, there may be an affect with some DSL services. With reference to this, the following modification should correct any problems. Capacitors are DoorKing Part Number 3501-037.

1. Install a .022 uf capacitor across terminals 1 and 5.
2. Install a .022 uf capacitor across terminals 2 and 4.
3. Be sure that the capacitor leads do not short to each other or to the case. We recommend that these leads be insulated.

## 1.6 TELEPHONE LINE WIRING – MULTIPLE UNITS

If any alarm systems are installed on the phone line, be sure that the alarm interface precedes the 1812 by-pass switch interface.

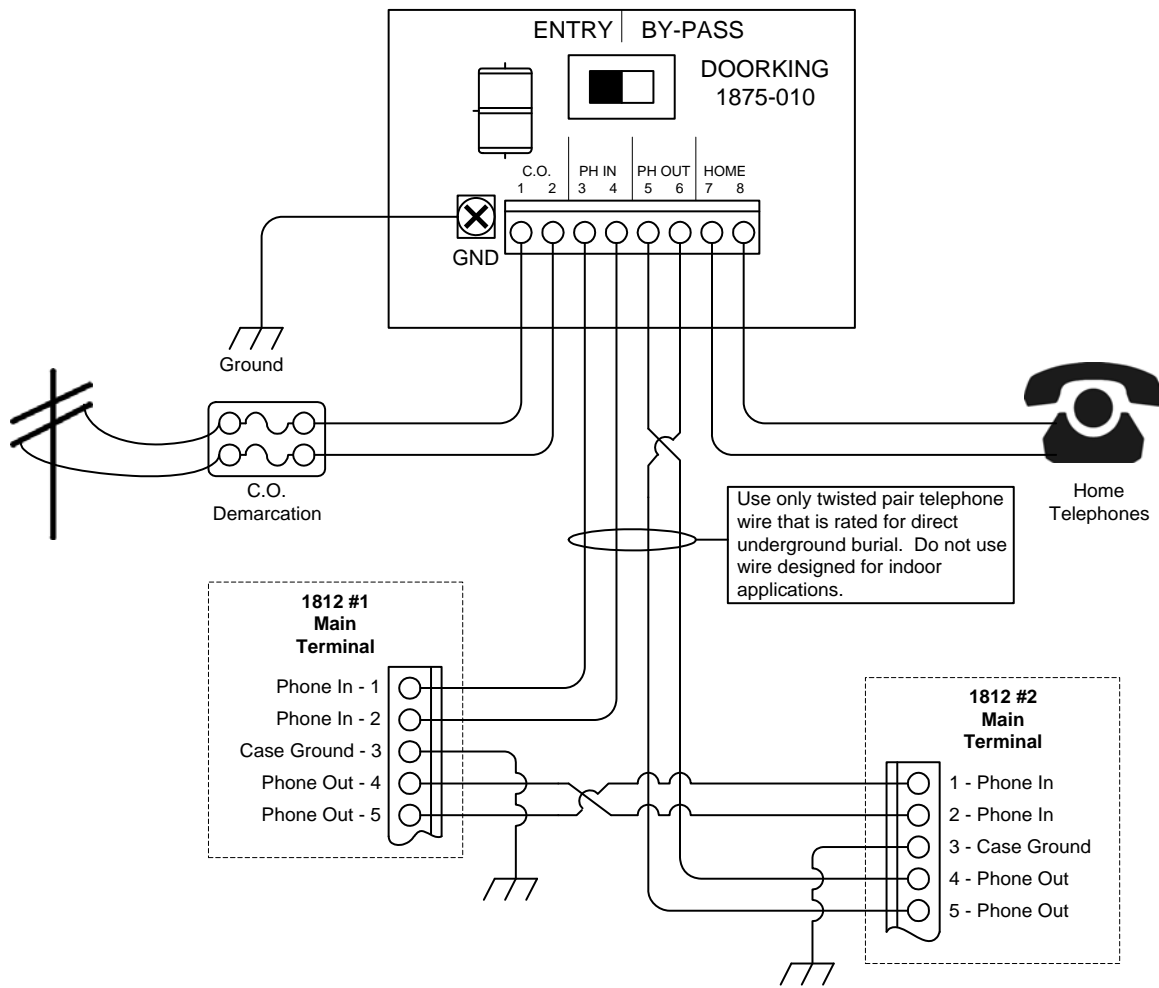

Use this wiring scheme if more than one 1812 will be installed on the same phone line. Up to five (5) 1812 units may be wired in series using this method. Additional units are connected PHONE OUT to PHONE IN; PHONE OUT to PHONE IN, etc.

Each 1812 unit must be programmed for MULTIPLE SYSTEMS, each must be programmed with a unique ATTENTION NUMBER, and each must be programmed with a unique MASTER CODE.

1. Connect PHONE IN wires from BY-PASS switch to 1812 #1 PHONE IN terminals 1 & 2.
2. Connect PHONE OUT wires from 1812 #1 (terminals 4 & 5) to 1812 #2 PHONE IN terminals 1 & 2.
3. Connect PHONE OUT wires from 1812 #2 (terminals 4 & 5) to PHONE OUT terminals on the BY-PASS switch.
4. Check for polarity on the phone "IN" wires, terminals 1 and 2. Terminal 2 must be positive with respect to terminal 1. Set a VOM meter to measure DC volts. Place the positive lead on terminal 2 and the negative lead on terminal 1. If the meter shows a positive voltage - OK. If the meter shows a negative voltage (needle moves off scale to the left), reverse the wires on terminals 1 and 2.
5. Surge protection is recommended on both phone in and phone out lines. Use DoorKing phone line surge suppressers (p/n 1877-010) or equivalent.

## 1.7 INTERCOM MODE WIRING – SINGLE UNIT

Use this wiring diagram when a single 1812 is programmed for intercom mode and is connected directly to another telephone or to an un-used C.O. port on a PBX or KSU type system.



Programmed for  
INTERCOM MODE

1. When the 1812 is programmed for intercom mode, it provides the constant source of DC voltage necessary for communication. The intercom mode also disconnects the phone in terminals (1 and 2) since they are not used.
2. Be sure that the 1812 is programmed in the intercom mode when connecting the unit as shown above.
3. Use only twisted pair telephone wire that has proper insulation for direct underground burial. Do not use thinly insulated wire, even if the phone lines will be run in a conduit. Do not make any splices to the phone lines. If splices are made, they must be soldered and insulated in a watertight enclosure.
4. Surge protection is recommended on the phone out lines. Use DoorKing phone line surge suppresser (p/n 1877-010) or equivalent.

## 1.8 INTERCOM MODE WIRING – MULTIPLE UNITS

Use this wire diagram when multiple 1812 units will be connected together in an intercom mode and connected directly to another telephone or to an open C.O. port on a PBX or KSU system. Pay particular attention to the notes below.

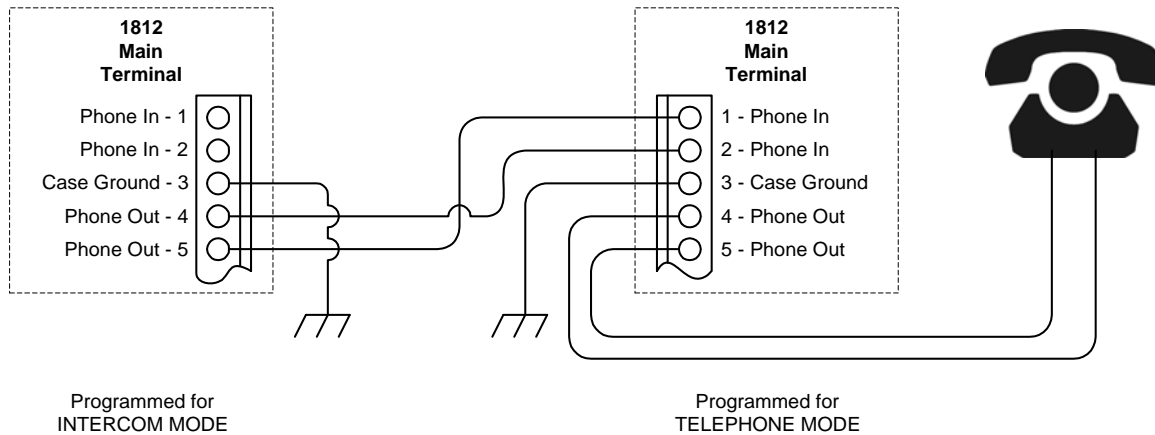

1. Up to five (5) 1812 units can be wired in series using this method. Additional units are connected PHONE OUT to PHONE IN; PHONE OUT to PHONE IN, etc.
2. Each 1812 must be programmed for MULTIPLE SYSTEMS and each must have a unique ATTENTION NUMBER. Each unit should also be programmed with its own MASTER CODE.
3. The 1812 that is furthest away from the phone (phone system) must be programmed in the intercom mode. All other 1812 units in the loop must be programmed in the telephone mode.
4. Use only twisted pair telephone wire that has proper insulation for direct underground burial. Do not use thinly insulated wire, even if the phone lines will be run in a conduit. Do not make any splices to the phone lines. If splices are made, they must be soldered and insulated in a watertight enclosure.
5. Each 1812 must be powered by its own power transformer.
6. Surge protection (DoorKing p/n 1877-010 or equivalent) is recommended for both the phone in and phone out wires on all units in the system.

## 1.9 MAIN TERMINAL DESCRIPTION

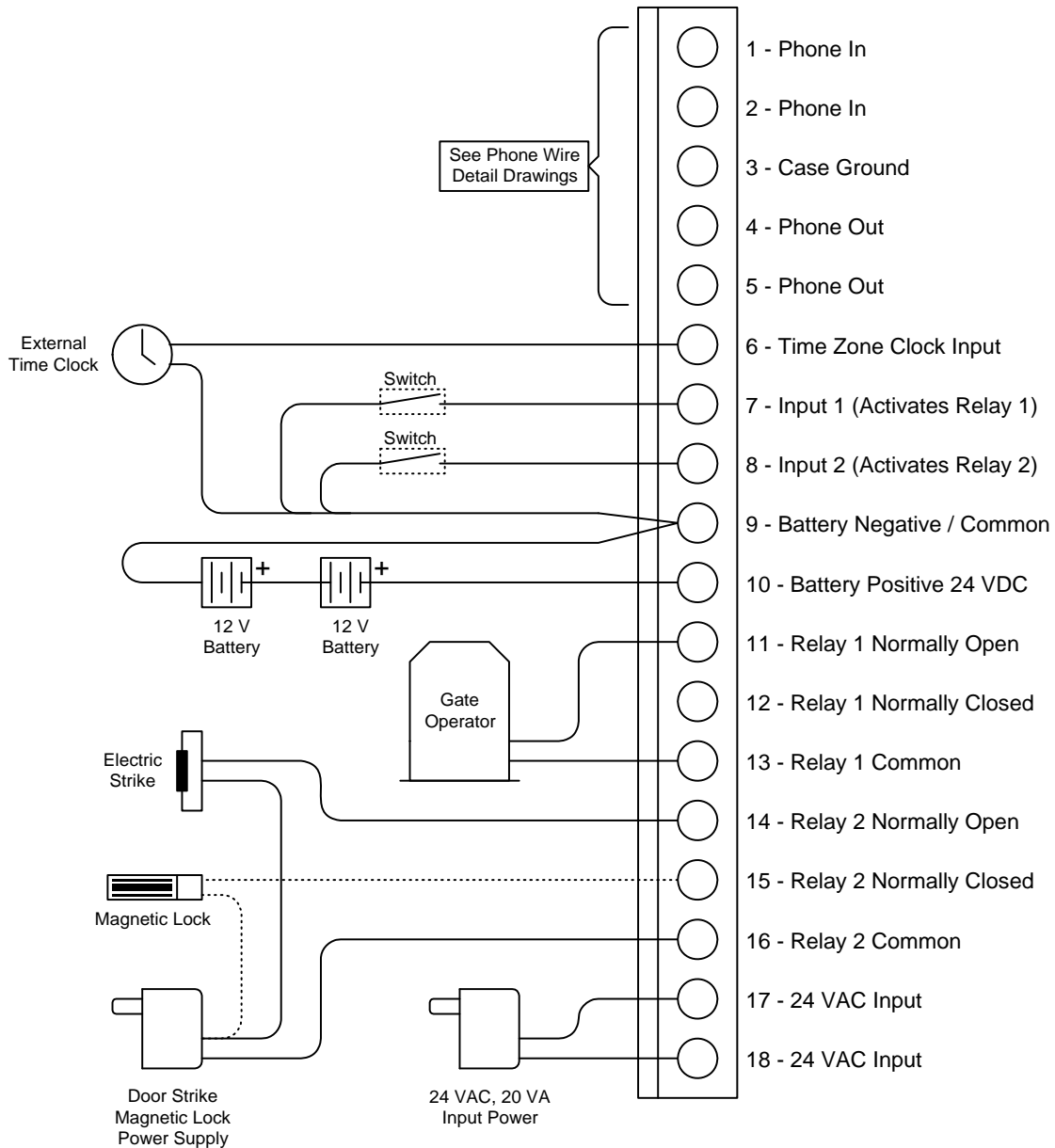

- External time clock input may be used to create an additional time zone for entry codes.
- Two 12 volt, .8 amp gel-cell batteries (DoorKing p/n 1801-008 or equivalent) can be connected in series to provide 24 volt DC power to operate the system or keep the system running in the event of a power outage.
- Back-up batteries are not required to keep the internal time clock in the 1812 system running. This clock has its own built-in standby power source.
- Relay contacts are rated for 3 amps @ 30 VAC maximum.
- It is highly recommended that a low voltage surge suppresser (DoorKing p/n 1878-010) be installed to help protect the telephone entry system from power surges.

## 1.10 PANEL TERMINAL DESCRIPTION

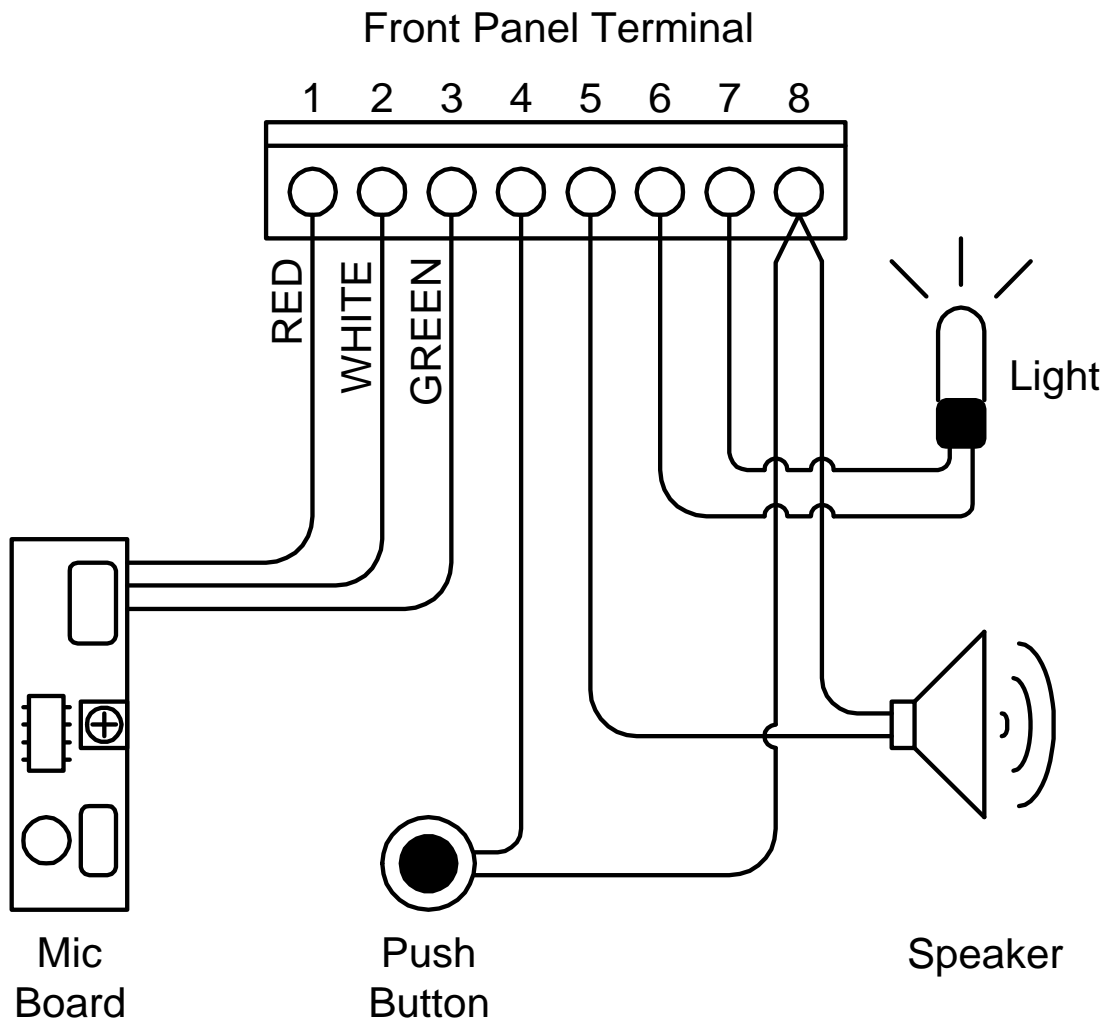

- If the 1812 is to be powered from a 24-Volt DC source such as batteries or solar panels, it is recommended that the panel light be removed. This will prolong the battery charge.
- There are no user-required connections to the front panel terminal strip. Diagram above is for reference and trouble shooting only.

## **SECTION 2 – PROGRAMMING**

The DoorKing 1812 Telephone Intercom System can be programmed by three different programming methods.

- **KEYPAD:** The keypad on the front of the entry system can be used to program all features in the 1812 unit. The MASTER CODE can only be programmed from the keypad.
- **COMPUTER:** Using the DoorKing Auto-Programming Software for Windows, almost all of the programmable features provided in the 1812 unit can be set using a PC.
- **TELEPHONE:** Using a touch-tone telephone, many of the programmable features can be programmed from the house or remotely from an off-site location.

**IMPORTANT! We strongly suggest that you read these programming instructions in their entirety before beginning any programming of this telephone entry system.**

### **2.1 PROGRAMMING INFORMATION**

#### ***2.1.1 Programming from the Keypad***

Follow the programming instructions as described in each section of this manual. The system will prompt you with short tones (beep) when programming steps have been followed correctly, and with a long tone (beeeeeep) when the programming step is ended.

This symbol \_ in the programming steps indicates numbers that you will need to enter, one number per symbol.

#### ***2.1.2 Programming with a PC***

Prior to programming the system with a personal computer and the DoorKing Auto-Programming Software for Windows, there is certain information that you must know and must program into the 1812 before the computer can communicate with it. See page 22 to set-up the 1812 for PC programming. Programming the unit with a PC may be accomplished either on-site (from the residence home) or remotely from an off-site location.

#### ***2.1.3 Programming with a Touch-Tone Telephone***

Follow these steps when programming the 1812 from the resident's touch-tone telephone. NOTE: The system attention number is factory set to 7. This can be changed to any number, see 2.2.2.

1. Press \* and then the system attention number 7 (beep).
2. Follow the programming instructions as described in each section of this manual. The system will prompt you with short (beep) tones when programming steps have been followed correctly.
3. When complete, hang up.

Follow these steps when programming the 1812 from an off-site touch-tone telephone. NOTE: The 1812 must be programmed to answer incoming calls.

1. Call the resident telephone number. The 1812 will answer with a short beep after the programmed number of rings.
2. Follow the programming instructions as described in each section of this manual. The system will prompt you with short (beep) tones when programming steps have been followed correctly.
3. When complete, hang up.

## 2.2 PC PROGRAMMING SET-UP

Prior to programming the 1812 with the DoorKing Auto-Programming Software for Windows, the system must have the MASTER CODE and SYSTEM SET-UP information programmed into it. These programming functions cannot be set with the PC and must be programmed from the system keypad.

### 2.2.1 Master Code

This programming step sets the system MASTER CODE. The master code is the four-digit number required to gain access to the system memory.

**NOTE: The master code cannot be programmed from an off-site location. The master code can only be programmed from the system keypad.**

**Factory setting = Last 4-digits of the serial number.**

1. Open the cabinet of the telephone entry system and turn the master code switch (the small toggle switch) on.
2. Enter a four-digit master code \_\_\_\_ then press \* (beep).
3. Turn the master code switch off and close the cabinet.

### 2.2.2 System Set-up Code

These steps will program the system set-up code. The system set-up code is a four-digit number that will program the 1812 for: 1st digit) single or multiple systems on the phone line, 2nd digit) the units attention number, 3rd digit) the number of rings to the house allowed before the system hangs up, 4th digit) single or double ring to the house. You will need to enter a four-digit number in step 2 (see chart below) to set the system set-up code.

**The factory default code setting is 1 7 3 1.**

1. Press \* 0 4 and then enter the four-digit MASTER CODE \_\_\_\_ (beep).
2. Enter the four-digit SET-UP CODE \_\_\_\_ and then press \* (beep).
3. Press 0# TOGETHER to end this programming step (beeeeeep).

Digit Step 2	Valid Entries	Function
1 st	0 or 1	Enter 1 for a single system, or enter 0 when multiple systems are sharing the phone line.
2 nd	0 – 9	Unit attention number.
3 rd	2 – 9	Number of rings to the house before the unit hangs up.
4 th	0 or 1	Enter 0 for the standard long ring, or enter 1 for the double ring.

**STOP!!**

If the telephone entry system is to be programmed from a PC, no other programming is required at the system itself. Complete the 1812 programming using the Auto-Programming Software. However – if the 1812 IS NOT on a shared phone line, then you must program Sections 2.3.5 and 2.3.6. If you are not programming the 1812 using the software, continue with the remaining sections in this manual.



## 2.3 GENERAL PROGRAMMING

Proceed with the programming steps on the following pages if PC programming will not be used.

### 2.3.1 Relay Strike Time

These steps will program Relay 1 and Relay 2 strike times. Strike times can be programmed from 1/4 second (enter 00 in step 4) up to 99 seconds by entering the desired time in seconds.

1. Press \* 0 3 and enter the four-digit MASTER CODE \_ \_ \_ \_ (beep).
2. Press 1 \* (beep) to set relay 1, **or** 2 \* (beep) to set relay 2 strike time.
3. Enter the two-digit strike time \_ \_ (00-99) then press \* (beep).
4. Repeat steps 2 and 3 to set other relay strike time.
5. Press 0# TOGETHER to end this programming step (beeeeeep).

### 2.3.2 Tone Open Numbers

These steps will program the tone open number(s) for both relay 1 and relay 2. Each relay is programmed independently. You will need to enter a four-digit number (see chart below) to set each relay. If a function is not desired, enter # in place of a number. For example, if you want the relay to have a momentary activation function only, and you want the relay to activate when the number 9 is pressed, enter 9 # # # in step 4.

1. Press \* 0 5 and enter the four-digit MASTER CODE \_ \_ \_ \_ (beep).
2. Press 1 \* (beep) to set relay 1, **or** press 2 \* (beep) to set relay 2.
3. Enter the four-digit tone open number code \_ \_ \_ \_ then press \* (beep).
4. Repeat steps 3 and 4 to set the other relay tone open number(s).
5. Press 0# TOGETHER to end this programming step (beeeeeep).

Digit Step 3	Function
1 st	Momentary activation. The relay will activate for its programmed strike time.
2 nd	Hold open. The relay will activate and remain activated until commanded to deactivate.
3 rd	Deactivate relay.
4 th	Hold open 1 hour. The relay will activate for 1 hour and then deactivate itself.

### **2.3.3 Phone / Intercom Mode**

The 1812 is normally connected in series with a residents incoming phone line, which supplies a constant source of DC voltage. When the 1812 is connected in this manner, program the unit for PHONE mode.

If the 1812 is to be connected to an open C.O. (Central Office) port on a key type telephone system, or if the 1812 is connected directly to another telephone without a C.O. line, program the unit for INTERCOM mode. When programmed in intercom mode, the 1812 will supply the constant DC voltage necessary for operation and will disconnect the PHIN terminals from the circuit since these are not used in intercom mode.

If the 1812 is programmed for the intercom mode, the call forwarding and preprogrammed dial-out phone number features will not work.

1. Press \* 0 6 and enter the four-digit MASTER CODE \_ \_ \_ \_ (beep).
2. Press 1 \* (beep) for phone mode, **or** press 0 \* (beep) for intercom mode.
3. Press 0# TOGETHER to end the programming step (beeeeeep).

### **2.3.4 Talk Time**

This programming sequence sets the maximum time allowed for conversation when the entry system places a call to the residents house, or if call forwarding is active, or if any of the three dial out numbers are used. The talk can be set from 1 second up to 255 seconds (4 minutes, 15 seconds) and is entered as a three-digit number. For example, to set a talk time of 30 seconds, enter 030 in step 3.

1. Press \* 0 8 and enter the four-digit MASTER CODE \_ \_ \_ \_ (beep).
2. Enter the three-digit talk time code \_ \_ \_ then press \* (beep).
3. Press 0# TOGETHER to end this programming step (beeeeeep).

### **2.3.5 Answer Incoming Call**

The 1812 can be programmed to answer calls placed to the residence from an outside phone line. When this feature is turned on, the 1812 will pick-up the call after the number of rings programmed in section 2.3.6. This then allows remote programming or remote relay activation of the system. If this feature is turned off, the 1812 will not answer any call regardless of the number of rings programmed in 2.3.6.

1. Press \* 1 5 and enter the four-digit MASTER CODE \_ \_ \_ \_ (beep).
2. Press 0 \* (beep) to turn this feature off, or press 1 \* (beep) to turn this feature on.
3. Press 0# TOGETHER to end this programming step (beeeeeep).

### **2.3.6 Number of Rings**

This programming section sets the number of rings that the 1812 will allow to pass through the system before it picks up the call. Some things to consider when programming this section is to not set the number of rings low as this may cause the 1812 to answer calls that are not intended for it. If the resident has an answer machine on their phone, this may present a problem. If the answer machine is set to answer on the fourth ring, and the 1812 is set to answer on the 6th ring, the answer machine will always pick-up the call before the 1812 does. On the other hand, if the 1812 is set to answer on the fourth ring, and the answer machine is set to pick-up the call on the 6th ring, the 1812 will always answer the call unless the answer incoming call (section 2.3.5) is turned off. The number of rings to answer can be set from 1 to 99 rings and must be entered as a two-digit number. For example, if you want the 1812 to answer the call after the sixth ring, enter 06 in step 3.

1. Press \* 1 8 and enter the four-digit MASTER CODE \_ \_ \_ \_ (beep).
2. Enter the number of rings \_ \_ then press \* (beep).
3. Press 0# TOGETHER to end this programming step (beeeeeep).

## 2.4 TIME FUNCTION PROGRAMMING

### 2.4.1 Time Clock Programming

This programming sequence programs the calendar chip in the 1812 system for the current time and date. The calendar chip must be programmed if any of the time related features are going to be used.

1. Press \* 3 3 and enter the four-digit MASTER CODE \_ \_ \_ \_ (beep).
2. Enter the current hour and minutes \_ \_ \_ \_ then press \* (beep). Do not use military (24 hour) time format, simply enter the hour (2 digits) and the minutes (2 digits). For example, 8:30 is entered as 0830 whether it is AM or PM.
3. Press 0 \* (beep) for AM, **or** press 1 \* (beep) for PM.
4. Enter the month \_ \_ , day of the month \_ \_ , year \_ \_ , day of the week \_ , and then press \* (beeeeeep). NOTE: When entering the day of the week, Sunday = 1, Saturday = 7.

### 2.4.2 Do Not Disturb Time Zone Programming

The Do Not Disturb (DND) feature allows the resident to program a time zone when they do not want the 1812 to ring the house phones or to call forward when the call button on the unit is pressed. For example, a resident may program a do not disturb time zone from 10 PM to 7 AM on certain days of the week, or all seven days. Once the DND time zone has been programmed, it can be turned on or off as needed.

1. Press \* 3 4 and enter the four-digit MASTER CODE \_ \_ \_ \_ (beep).
2. Press 0 \* (beep) to turn DND off, **or** press 1 \* (beep) to turn DND on.
3. Enter the begin time hour and minutes \_ \_ \_ \_ then press 0 \* (beep) for AM, **or** press 1 \* (beep) for PM.
4. Enter the end time hour and minutes \_ \_ \_ \_ then press 0 \* (beep) for AM, **or** press 1 \* (beep) for PM.
5. Enter the days of the week that the DND time zone is to be active \_ \_ \_ \_ \_ \_ then press \* (beep). NOTE: Sunday = 1, Saturday = 7. To skip a day (or days) of the week, enter # in place of the day. For example, if the DND time zone is to be active Monday through Friday only, enter 2 3 4 5 6 # # in step 6.
6. Press 0# TOGETHER to end this programming step (beeeeeep).

### **2.4.3 Automatic Relay Activation Time Zones**

This program sequence sets up time zones to automatically activate and deactivate the relays on the control board. Each relay can be programmed with two independent time zones. Time zones 1 and 2 affect relay 1 operation; time zones 3 and 4 affect relay 2 operation. These time zones can be independently turned on or off after they have programmed.

1. Press \* 3 5 and enter the four-digit MASTER CODE \_ \_ \_ \_ (beep).
2. Enter the time zone number \_ then press \* (beep).
3. Press 0 \* (beep) to turn time zone off, **or** press 1 \* (beep) to turn time zone on.
4. Enter the begin time hour and minutes \_ \_ \_ \_ then press 0 \* (beep) for AM, **or** press 1 \* (beep) for PM.
5. Enter the end time hour and minutes \_ \_ \_ \_ then press 0 \* (beep) for AM, **or** press 1 \* (beep) for PM.
6. Enter the days of the week that the time zone is to be active \_ \_ \_ \_ \_ \_ then press \* (beep). NOTE: Sunday = 1, Saturday = 7. To skip a day (or days) of the week, enter # in place of the day. For example, if the time zone is to be active Saturday and Sunday only, enter 1 7 # # # # # in step 6.
7. Repeat steps 3 through 7 to program the other time zones.
8. Press 0# TOGETHER to end this programming step (beeeeeep).

### **2.4.4 Entry Code Time Zones**

This programming sequence sets up a time zone for all four-digit entry codes that have been programmed into the time zoned entry code location areas. Entry codes that are programmed into these location areas will not work outside of the programmed time zone. This time zone can be turned on or off once it is programmed. See 2.6.1 to program entry codes.

1. Press \* 3 6 and enter the four-digit MASTER CODE \_ \_ \_ \_ (beep).
2. Press 0 \* (beep) to turn time zone off, **or** press 1 \* (beep) to turn time zone on.
3. Enter the begin time hour and minutes \_ \_ \_ \_ then press 0 \* (beep) for AM, **or** press 1 \* (beep) for PM.
4. Enter the end time hour and minutes \_ \_ \_ \_ then press 0 \* (beep) for AM, **or** press 1 \* (beep) for PM.
5. Enter the days of the week that the time zone is to be active \_ \_ \_ \_ \_ \_ then press \* (beep). NOTE: Sunday = 1, Saturday = 7. To skip a day (or days) of the week, enter # in place of the day. For example, if the entry code time zone is to be active Monday through Friday only, enter 2 3 4 5 6 # # in step 6.
6. Press 0# TOGETHER to end this programming step (beeeeeep).

### **2.4.5 Call Forward Time Zone**

This programming sequence sets up a time zone for the call-forwarding feature. The 1812 will automatically send calls to the forwarding number if the time and day are within the time zone boundary and the time zone is turned on. This feature is also dependent on the call forward feature being turned off and the time and day being outside the DND time zone if that feature is enabled. This sequence simply sets the call forwarding time zone. You must also program a call forwarding number (2.5.1) and turn the call forwarding **off** (2.5.2).

1. Press \* 3 7 and enter the four-digit MASTER CODE \_ \_ \_ \_ (beep).
2. Press 0 \* (beep) to turn time zone off, **or** press 1 \* (beep) to turn time zone on.
3. Enter the begin time hour and minutes \_ \_ \_ \_ then press 0 \* (beep) for AM, **or** press 1 \* (beep) for PM.
4. Enter the end time hour and minutes \_ \_ \_ \_ then press 0 \* (beep) for AM, **or** press 1 \* (beep) for PM.
5. Enter the days of the week that the time zone is to be active \_ \_ \_ \_ \_ \_ then press \* (beep). NOTE: Sunday = 1, Saturday = 7. To skip a day (or days) of the week, enter # in place of the day. For example, if the call forward time zone is to be active Monday through Friday only, enter 2 3 4 5 6 # # in step 6.
6. Press 0# TOGETHER to end this programming step (beeeeeep).

### **2.4.6 Flash Code Programming**

Flash codes are entry codes that are valid for a single day only. This programming sequence sets the day of the month that the flash codes will be active. There is one flash entry code per relay.

1. Press \* 4 5 and enter the four-digit MASTER CODE \_ \_ \_ \_ (beep).
2. Press 1 \* (beep) for relay 1 flash code, **or** press 2 \* (beep) for relay 2 flash code.
3. Enter the day of the month that the code is to be valid \_ \_ then press \* (beep).
4. Repeat steps 3 and 4 to enter the other relay flash day.
5. Press 0# TOGETHER to end the programming session (beeeeeep).

The flash code will be valid for a single day only. For example, if you program a flash code on July 1st to be active on July 10th, the code will become active on midnight July 10th, and expire on midnight July 11th. The code will not be active on August 10th. Programming flash codes is a two-step process. This sequence simply sets the day that the flash codes will be valid. Go to section 2.6.1 to program the four digit flash code.

## 2.5 PROGRAMMING DIAL-OUT FUNCTIONS

### 2.5.1 Call Forward Programming

These steps program the call forwarding telephone number into the 1812 memory. Call forwarding can only be used when the 1812 is programmed in phone mode (see 2.3.3).

1. Press \* 1 0 and enter the four-digit MASTER CODE \_ \_ \_ \_ (beep).
2. If the forwarding number is long distance, press 1 then enter the area code \_ \_ \_ and then press \* (beep). If the forwarding number is 10 digits, press # then enter the area code \_ \_ \_ and then press \* (beep). If the forwarding number is local, press # # # # then press \* (beep).
3. Enter the seven-digit phone number \_ \_ \_ \_ \_ \_ \_ then press \* (beep).
4. Press 0# TOGETHER to end this programming step (beeeeeep).

### 2.5.2 Call Forward On / Off

These programming steps are used to turn call forwarding on or off.

1. Press \* 1 4 and enter the four-digit MASTER CODE \_ \_ \_ \_ (beep).
2. Press 1 \* (beep) to turn call forwarding ON, **or** press 0 \* (beep) to turn call forwarding OFF.
3. Press 0# TOGETHER to end this programming step.

### 2.5.3 Preprogrammed Phone Numbers

The 1812 system has the capability of calling out to three preprogrammed phone numbers from the system keypad. These numbers are different than the call forwarding number that was programmed in 2.5.1. When a visitor presses 01, 02, or 03 on the system keypad, the 1812 will call the preprogrammed phone number programmed under the specific directory number. This feature cannot be used if the 1812 is programmed in the intercom mode (2.3.3).

To program the number that will be called when 0 1 is pressed on the keypad:

1. Press \* 2 1 (**see note below**) and enter the four-digit MASTER CODE \_ \_ \_ \_ (beep).
2. If the number to be called is long distance, press 1 then enter the area code \_ \_ \_ and then press \* (beep). If the forwarding number is 10 digits, press # then enter the area code \_ \_ \_ and then press \* (beep). If the number to be called is local, press # # # # then press \* (beep).
3. Enter the seven-digit phone number \_ \_ \_ \_ \_ \_ \_ then press \* (beep).
4. Press 0# TOGETHER to end this programming step (beeeeeep).

#### STEP 1 NOTE:

Press \* 2 2 to program the phone number called when 02 is pressed on the keypad.

Press \* 2 3 to program the phone number called when 03 is pressed on the keypad.

## 2.6 ENTRY CODE PROGRAMMING

### 2.6.1 Four-Digit Entry Code Programming

This programming sequence programs four digit entry codes into the system memory. You can store up to 50 unique entry codes into the system memory, however these codes will perform different functions dependent on the location code that they have been stored in. Each relay can have 14 momentary activation codes, one flash code, five hold codes, and five time zoned codes. We suggest that you keep a log of all entry codes programmed into the system (see appendix).

1. Press \* 0 2 and enter the four-digit MASTER CODE \_ \_ \_ \_ (beep).
2. Enter the location code \_ \_ then press \* (beep).
3. Enter the four-digit entry code \_ \_ \_ \_ then press \* (beep).
4. Repeat steps 2 and 3 to enter additional codes.
5. Press 0# TOGETHER to end this programming step (beeeeeep).

Relay 1		Relay 2	
Location Code	Function	Location Code	Function
01 – 14	Momentary	26 – 39	Momentary
15	Flash	40	Flash
16 – 20	Hold	41 – 45	Hold
21 - 25	Time Zoned	46 - 50	Time Zoned

### 2.6.2 Delete Four-Digit Codes

This programming sequence allows you to delete individual four digit entry codes.

1. Press \* 0 2 and enter the four-digit MASTER CODE \_ \_ \_ \_ (beep).
2. Enter the location code \_ \_ then press \* (beep).
3. Enter # # # # then press \* (beep).
4. Repeat steps 2 and 3 to delete more entry codes.
5. Press 0# TOGETHER to end this programming step (beeeeeep).

### 2.6.3 Delete ALL Four-Digit Entry Codes

This programming sequence deletes all four-digit entry codes that have been programmed into the system. **CAUTION: this programming step is irreversible once it is started.**

1. Press \* 0 0 and enter the four-digit MASTER CODE \_ \_ \_ \_ (beep).
2. Press 9 9 9 9 \* (beep). This programming sequence will automatically end itself. This will be indicated by a long tone (beeeeeep).



## **SECTION 3 – ADJUSTMENTS**

### ***Speaker Volume***

The speaker volume potentiometer is labeled SPEAKER VOL on the control board. The speaker volume should be adjusted for adequate sound. Adjusting the speaker volume too loud will cause feedback from the microphone.

1. Open the front of the telephone entry system and locate the speaker volume adjustment.
2. Push the "Push To Call" button to place a call to the resident. While they are talking, adjust the speaker volume potentiometer for adequate sound. To increase the volume rotate the potentiometer clockwise, to decrease the volume rotate the potentiometer counter clockwise.

### ***Feedback 1***

The feedback 1 potentiometer is labeled FB1 on the control board. This adjustment minimizes feedback from the microphone to the speaker when the system is connected to the resident telephone.

1. Open the front of the telephone entry system and locate the feedback adjustment.
2. Push the "Push To Call" button to place a call to the resident. After they answer, ask the resident to remain silent.
3. While rubbing your finger across the microphone hole, rotate the feedback potentiometer clockwise, and then counter clockwise. When the noise from the speaker is minimum, this is the correct adjustment for the feedback potentiometer.

### ***Feedback 2***

The feedback 2 potentiometer is labeled FB2 on the control board. This adjustment minimizes feedback from the microphone to the speaker when the system has placed a call to an outside phone line. NOTE: Feedback 2 is not used when the 1812 is programmed in the intercom mode.

1. Open the front of the telephone entry system and locate the feedback adjustment.
2. Enter one of the preprogrammed phone number directory codes (01, 02, 03) on the system keypad to place a call to an outside number (see 2.5.3 to program an outside number). After the party answers, ask them to remain silent.
3. While rubbing your finger across the microphone hole, rotate the feedback potentiometer clockwise, and then counter clockwise. When the noise from the speaker is minimum, this is the correct adjustment for the feedback potentiometer.

### ***Master Code Switch***

The master code switch is left in the off position for normal operation. Turn the master code switch on when setting the system master code. See programming instructions to set the system master code.

If the master code switch is turned on and a new master code is not entered, the system will sound a short tone after approximately 30 seconds. This tone will continue every 30 seconds until a new master code is entered, or until the switch is turned off. After the switch is turned off, the display will remain lit for approximately 30 seconds, and then will go off.

# Circuit Board Adjustment Locations

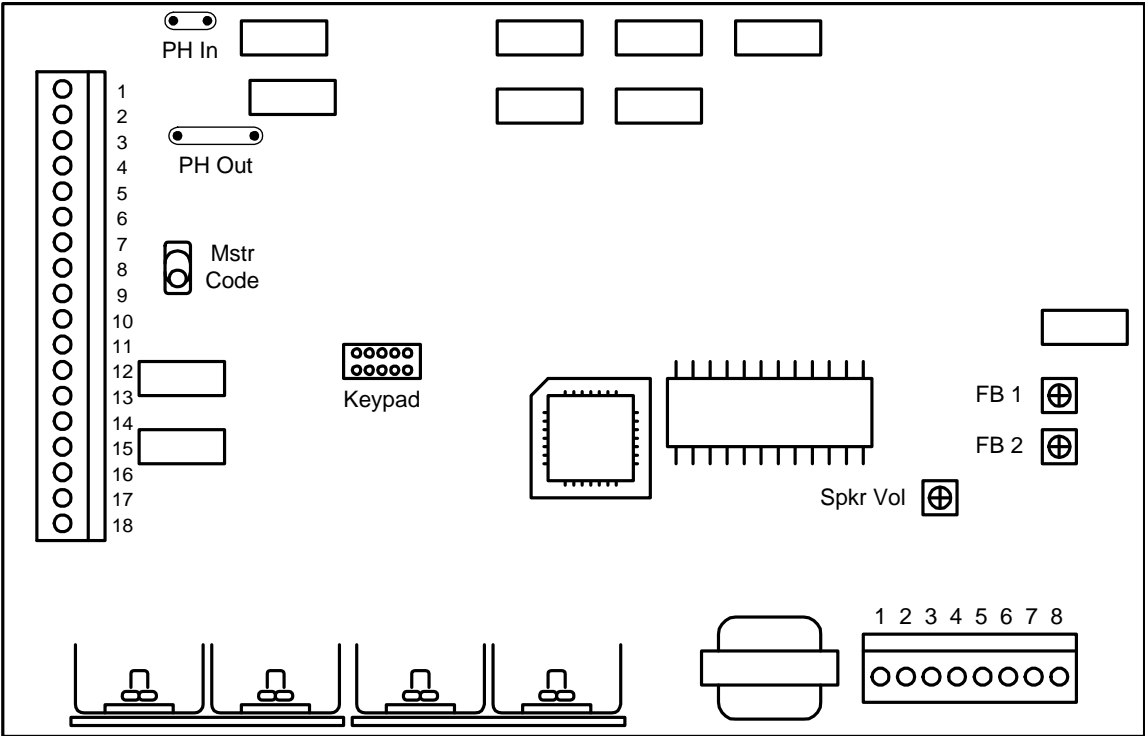

## **SECTION 4 – OPERATING INSTRUCTIONS**

### **4.1 Calling the Resident**

To place a call from the 1812 to the resident's house, the guest simply presses the PUSH TO CALL button located on the faceplate. Once the guest has been identified by voice communication, the resident may grant them access by pressing the appropriate tone open number, or they may deny access by simply hanging up.

1. To grant access to a guest, press the programmed tone open number. (The factory setting for the tone open number is 9, however this can be programmed to any number desired. See section 2.3.2 to program tone open numbers.) The 1812 will respond with a confirming tone and will open the door or gate.
2. To deny access, hang up the telephone.

Prior to ringing the resident's phones, the 1812 will perform several logic steps to check the status of the Do Not Disturb (DND) and Call Forwarding features. If the DND feature is turned on, the DND time zone will be checked. If the time is within the DND time zone boundary, the system will not ring the resident's phones and will not call forward, even if the call forward feature is turned on. If the DND feature is turned on but the time is outside the DND time zone, the system will then check the call forwarding function. If the DND feature is turned off, the system will check the call forwarding function.

If the call forwarding feature is turned on, the 1812 will automatically dial out the preprogrammed call forwarding number when the guest pushes the Push To Call button regardless if the call forwarding time zone is turned on or off. If the call forwarding feature is turned off, the system will then check the call forwarding time zone. If the call forwarding time zone is turned on and the time is within the call forwarding time zone boundaries, the system will dial the preprogrammed call forwarding number. If the call forwarding time zone is turned on and the time is outside the call forwarding time zone boundaries, the system will ring the resident's phones. If the call forwarding time zone is turned off, the system will ring the resident's phones.

### **4.2 Call Waiting**

When the resident is on their telephone and a guest pushes the Push To Call push button, the 1812 will sound a short tone in the resident's handset. This indicates to the resident that a guest is at their door or gate.

1. To place the outside call on HOLD, press #. This will connect the resident's telephone with the 1812.
2. To grant the guest access, press the programmed tone open number. The 1812 will respond with a confirming tone, open the door or gate, and will reconnect the resident's phone with their outside call.
3. To deny the guest access, press #. The 1812 will disconnect from the resident's phone and reconnect it to the outside call.

The same process can be used when the resident is talking to a guest at the 1812 and an outside call comes in. The resident can place the 1812 on hold and switch to the outside call.

### **4.3 Preprogrammed Numbers**

To use the preprogrammed phone number feature, the guest simply presses 01, 02, or 03 on the system keypad. The 1812 will automatically dial out the specific preprogrammed phone number. Once the call is answered at the other end, that party may grant or deny a guest access by pressing the programmed tone open number or simply hanging up. NOTE: These numbers are different than the call forwarding number.

1. To call the first preprogrammed number, press 01 on the keypad.
2. To call the second preprogrammed number, press 02 on the keypad.
3. To call the third preprogrammed number, press 03 on the keypad.

### **4.4 Entry Codes**

The four-digit entry codes will operate either relay 1 or relay 2 depending on the location code that the particular four-digit code has been stored under. The specific operation of the code is also dependent on the location code used (see 2.6.1).

1. Press # .
2. Enter the four-digit entry code \_ \_ \_ \_ .

When the entry code is entered on the keypad, the system will check its memory to see if the code entered is stored and under which location code it has been stored. If the entry code is stored under a momentary activation location code, either relay 1 or relay 2 will activate for the programmed strike time depending on which location code the entry code was stored under. If the entry code is stored under a hold location code, the specific relay will latch on until another entry code is entered on the keypad.

If the entry code entered is stored under a time zoned location, the system will first check to see if the entry code time zone is turned on or turned off. If this time zone is turned off, the entry code will activate the specific relay for the programmed strike time. If the entry code time zone is turned on, the system will check the clock to determine if the entry code is within the time zone boundary. If the entry code is within the time zone boundary, the respective relay will activate for the programmed strike time. If the entry code is outside of the time zone boundary, the relay will not activate.

If the entry code is stored under a flash location, the system will check the clock to determine if the current day is the programmed operating day for the entry code. If the current day is valid, the respective relay will operate for the programmed strike time. If the current day is not valid, the relay will not operate. Once the programmed operating day is past, the flash entry code will not work unless a new flash operating day is programmed into the system.

## ***Resident Operating Instructions***

The following operating instructions assume that the 1812 features are being turned on and off from the resident's touch tone telephone and that the system attention number is 7 (factory setting). If the system attention number has been changed, use the new attention number in step 1. These steps can also be performed at the system keypad by skipping step 1 (start with step 2) and by pressing 0 # together in place of step 4.

### ***4.5 Call Forwarding Enable / Disable***

To use the call forward feature, be sure that a call forwarding number has been programmed into the system memory (2.5.1). This operating step turns the call-forwarding feature on or off. If this feature is turned on, all calls from the 1812 will be forwarded regardless of whether the call forwarding time zone is turned on or off. If the call forwarding feature is to be time zoned, this step must be programmed off.

1. Pick up your telephone and press \* 7 (beep).
2. Press \* 1 4 and enter the four-digit MASTER CODE \_ \_ \_ \_ (beep).
3. Press 1 \* (beep) to turn call forwarding on, **or** press 0 \* (beep) to turn call forwarding off.
4. Hang up.

### ***4.6 Call Forward Time Zone Enable / Disable***

To use the call forwarding time zone feature, be sure that a call forwarding time zone has been programmed into the system (2.4.5), that a call forwarding number is programmed (2.5.1), and that the call forwarding is turned off (2.5.2). This will cause the 1812 to check the time zone before forwarding any calls to the forwarding number.

1. Pick up your telephone and press \* 7 (beep).
2. Press \* 3 7 and enter the four-digit MASTER CODE \_ \_ \_ \_ (beep).
3. Press 1 \* (beep) to turn call forward time zone on, **or** press 0 \* (beep) to turn call forward time zone off.
4. Hang up.

### ***4.7 Do Not Disturb Enable / Disable***

To use the Do Not Disturb feature, be sure that a do not disturb time zone has been programmed into the system memory (2.4.2). When the do not disturb feature is turned on, the 1812 will not allow calls from the unit to ring up to the house and will not allow calls to be forwarded regardless of whether the call forwarding feature is turned on or off.

1. Pick up your telephone and press \* 7 (beep).
2. Press \* 3 4 and enter the four-digit MASTER CODE \_ \_ \_ \_ (beep).
3. Press 1 \* (beep) to turn do not disturb on, **or** press 0 \* (beep) to turn do not disturb off.
4. Hang up.

#### **4.8 Entry Code Time Zone Enable / Disable**

The entry code time zone affects only those entry codes programmed under the time zoned entry code location codes 21-25 for relay 1, 46-50 for relay 2. To use this feature, be sure that four-digit entry codes have been programmed into the system under the proper location codes, and be sure that an entry code time zone has been programmed (2.4.4).

1. Pick up your telephone and press \* 7 (beep).
2. Press \* 3 6 and enter the four-digit MASTER CODE \_ \_ \_ \_ (beep).
3. Press 1 \* (beep) to turn the entry code time zone on, **or** press 0 \* (beep) to turn the entry code time zone off.
4. Hang up.

#### **4.9 Auto Relay Time Zones Enable / Disable**

The four automatic relay activation time zones can be turned on or off as required. Time zones one and two operate relay 1, while time zones three and four operate relay 2. To use this feature, be sure that the automatic relay activation time zones have been programmed (2.4.3).

1. Pick up your telephone and press \* 7 (beep).
2. Press \* 3 5 and enter the four-digit MASTER CODE \_ \_ \_ \_ (beep).
3. Enter the time zone number \_ then press \* (beep).
4. Press 1 \* (beep) to turn the auto relay time zone on, **or** press 0 \* (beep) to turn the auto relay time zone off.
5. Hang up.

#### **4.10 Auto Answer Enable / Disable**

The auto answer feature must be turned on to allow relay activation and programming of the system from a remote location. When the residents phone number is called, the 1812 will pick up the call after the programmed number of rings (2.3.6).

1. Pick up your telephone and press \* 7 (beep).
2. Press \* 1 5 and enter the four-digit MASTER CODE \_ \_ \_ \_ (beep).
3. Press 1 \* (beep) to turn auto answer on, **or** press 0 \* (beep) to turn auto answer off.
4. Hang up.

### **4.11 Relay Activation Check**

The 1812 can be called to check if relay 1, relay 2, or both relays in the system are latched and holding a door or gate in the open (unlocked) position.

1. Pick up your telephone and press \* 7 (beep).
2. Listen for the following sequence of tones. No tones: neither relay is activated. Relay 1 activated: beep - pause - beep - pause . . . Relay 2 activated: beep beep - pause - beep beep - pause . . . Both relays activated: beep beep beep - pause - beep beep beep - pause . . .
3. Hang up.

### **4.12 Remote Programming**

The 1812 can be programmed from a remote location using a touch-tone telephone. The auto answer feature must be turned on (4.10) to perform any remote programming. The 1812 master code cannot be programmed remotely.

1. Call the residents phone number. After the programmed number of rings (2.3.6) the 1812 will answer with a tone (beep).
2. Follow the desired programming steps in programming section of this manual.
3. When complete with the desired programming section, hang up. You cannot use 0# to end programming steps from a touch-tone telephone.

### **4.13 Remote Relay Activation**

The 1812 system relays can be activated from the house or from a remote (off site) location. The auto answer feature must be turned on (4.10) to activate any of the relays from a remote location.

To activate the relay(s) from the resident's house, perform the following steps.

1. Pick up your telephone and press \* 7 (beep).
2. Enter the desired tone open number \_ (beep).
3. Hang up.

To activate the relay(s) from a remote (off-site) location, perform the following steps.

1. Call the residents phone number. After the programmed number of rings (2.3.6) the 1812 will answer with a tone (beep).
2. Press \* 1 6 .
3. Enter the four-digit MASTER CODE \_ \_ \_ \_ (beep).
4. Enter the desired tone open number \_ (beep).
5. Hang up.

#### **4.14 Switch Input Operation**

A switch closure between terminals 7 and 9 will activate relay 1 for its programmed strike time. A switch closure between terminals 8 and 9 will activate relay 2 for its programmed strike time.

A switch closure between terminals 6 and 9 will activate the external time zone input. When this input is activated, entry codes that have been programmed into the time zone restricted location codes will not work.

The 1812 has two time zones available as a built in programming function. The external time clock input provides a method to activate a third time zone, but requires an external time clock.



## **SECTION 5 – MAINTENANCE**

The DoorKing telephone entry system is essentially a maintenance free device. When the unit is properly installed, it should provide years of trouble free service. Maintenance is limited to updating the directory and phone number and/or entry codes when residents move in or out.

The faceplate of the unit should be cleaned on a regular basis to keep contaminants in the air from sticking to the surface and possibly causing pitting. When cleaning the faceplate of the system, never use an abrasive cleaner or cloth. Stainless steel cleaner works very well with a soft cloth for systems with a stainless steel faceplate. A clean damp soft cloth should be used to clean gold plated faceplates.

### **5.1 TROUBLE SHOOTING**

If problems should develop with your telephone entry system, refer to the trouble-shooting guide on the following pages to try and correct any problems. Our experience has shown that a majority of reported problems are actually programming related and can be corrected on site. If problems persist and they cannot be corrected, contact your authorized DoorKing dealer for assistance. Before performing any trouble-shooting, check the following:

1. Have a good VOM meter handy to check voltages and continuity.
2. Have a telephone test set (DoorKing p/n 1800-050 or equivalent) to check the telephone line. Noise on the phone line will cause problems with the entry system.
3. Be sure that the entry system case is properly grounded.
4. Be sure that the telephone wires are twisted.
5. A hum on the system indicates that the phone line or 24 VAC power lines may be grounded. Check to be sure that the phone lines or power lines are not shorted to ground. Be sure that the cable used for communication is a twisted pair, good quality phone cable insulated for direct underground burial. Using phone wire that is designed for indoor use only can absorb moisture and cause a hum on your phone line.
6. Check the 24 VAC system power. Be sure that the transformer is properly rated (20 VA). Keep the wire run from the transformer to the entry system as short as possible. Use 16 or 18 AWG, 600 volt insulated wire only. **The importance of proper power wiring cannot be over stressed!**

#### ***Isolating Noise Problems***

If noise or hum is present on the residents phone line after installation of the 1812 telephone intercom system, use the procedure on the next page to find and correct the source of the noise. This procedure will require the use of a telephone test set (DoorKing p/n 1800-050 or equivalent). Typically, noise is usually introduced into the system because of incorrect wiring, poor quality of wire, wire runs exceeding maximum distances, phone and high voltage power wires running in the same conduit or in very close proximity to each other, a wrong type transformer was substituted, or the phone lines, power lines or 1812 circuit board is grounded.

## ***Isolating Noise Problems***

1. Remove all external items connected to the 1812 unit, such as back-up batteries, relay connections, push button switches, or time clocks. All terminals should be free of any wiring except terminals 1 and 2 (PHON IN WIRES), terminal 3 (CASE GROUND WIRE), terminals 4 and 5 (PHON OUT WIRES), and terminals 17 and 18 (24 VAC POWER WIRES). If noise is still present, proceed to step 2. If noise is gone, the source of the noise is one of the external devices that was connected to the 1812. Reconnect them one at a time until you find the item that is the source of the noise.
2. Place the BYPASS switch in the BYPASS mode (slide switch to right). If noise goes away, problem is with phone in/out wiring, power wiring, or 1812 unit. Place the BYPASS switch in the ENTRY SYSTEM mode (slide switch to left) and proceed to step 3. If noise is still present when switch is in the bypass mode, disconnect C.O. wires and HOUSE wires from bypass switch. Connect the C.O. wires to the HOUSE wires. If the noise goes away, the bypass switch is bad and needs to be replaced. If noise is still present, contact the telephone company for service.
3. Remove the PHON OUT wires from terminals 4 and 5 at the 1812 unit. Connect your handy phone directly to the loose PHON OUT wires. The wires should be dead and you should not have any dial tone on these wires. If you do have dial tone, the 1812 is wired incorrectly. Disconnect power immediately and refer to the wiring information section in this manual starting on page 7.
4. Disconnect your handy phone from the PHON OUT wires (step 3). Remove the PHON IN wires from terminals 1 and 2 at the 1812 unit. Connect the PHON IN wires to the PHON OUT wires. This completely disconnects the 1812 unit from the circuit. Check the phones in the house. If the noise is gone, problem is with or in the 1812 unit, or with the power supply or power wiring. Reconnect the PHON IN wires to terminals 1 and 2, and the PHON OUT wires to terminals 4 and 5, then proceed to step 5. If the noise is still present, problem is with the PHON IN or PHON OUT wires running from the 1812 unit to the bypass switch. These wires will need to be replaced and/or re-routed to correct the problem.
5. Disconnect the 24 VAC wires from terminals 17 and 18. If the phone line is now clear, the problem is in the 24 VAC power run. Check the power lines for a ground, or running next to high voltage wires, or an improper wire size and insulation, or too long of a wire run (see page 7 for wiring information). If noise is still present, go to step 6.
6. If noise is still present at this step in the trouble shooting sequence, this would indicate a short to ground internally in the 1812 unit. Remove the 8-pin front panel terminal strip from the circuit board, and check for noise again. If noise is gone, this would indicate a problem with the microphone board, speaker, push button, or lights on the front panel assembly. Check for any shorts to ground on any of these components or wiring. Check to be sure that none of the wires are pinched. If noise is still present, check the wires entering the back of the 1812 box and be sure that none are pinched. Be sure that these wires are not touching the back of the 1812 circuit board, possibly causing a short to ground. If all of the above steps fail to identify the source of noise, contact DoorKing for additional assistance.

SYMPTON	POSSIBLE SOLUTION(S)
Cannot get into programming mode.	<ul style="list-style-type: none"> <li>• Wrong master code entered. Start over.</li> <li>• Waiting too long between pushing buttons. Enter information quicker.</li> <li>• Keypad is not plugged into board correctly. Cable points down.</li> </ul>
System emits a long tone and cancels programming.	<ul style="list-style-type: none"> <li>• Waiting too long between pushing buttons.</li> <li>• Forgetting to press * first when programming.</li> </ul>
Keypad is dead.	<ul style="list-style-type: none"> <li>• No power. Check for 24 VAC input power.</li> <li>• Check that the keypad is properly connected to the circuit board. The cable on the plug points down when connected to the circuit board.</li> </ul>
Dial tone is heard on the 1812 speaker.	<ul style="list-style-type: none"> <li>• The system is not wired in series with the resident phone line. Check the PHON IN terminals (1 &amp; 2) and the PHON OUT terminals (4 &amp; 5).</li> </ul>
Buzz or noise on the line.	<ul style="list-style-type: none"> <li>• Check for a short to ground behind the circuit board.</li> <li>• Check for pinched wires near the door hinge.</li> <li>• Check for 24-volt power shorted to a conduit.</li> <li>• Check for a phone line shorted to ground.</li> <li>• Check that the phone wires are twisted.</li> <li>• Check that all wires, speaker, keypad, etc., are isolated from ground.</li> <li>• Check that the cabinet is properly grounded. Be sure case ground (terminal 3) is not used as a low voltage common.</li> <li>• Check for excessive voltage drop on 24 VAC power.</li> <li>• Check phone line with telephone test set.</li> </ul>
Buzz on telephone line.	<ul style="list-style-type: none"> <li>• Remove the PHON IN and PHON OUT wires from the 1812 terminal strip. Connect the PHON IN wires to the PHON OUT wires. If the noise is still present, bad PHON IN or PHON OUT wires.</li> <li>• Remove 24 VAC wires from the terminal strip. Check house phones. If noise goes away, 24 VAC wires are probably grounded. Replace wires.</li> <li>• Check internal wires, switch wires, battery wires for any pinches or shorts.</li> </ul>
Phones in home will not ring.	<ul style="list-style-type: none"> <li>• Check that the by-pass switch is not set to by-pass mode.</li> <li>• Do Not Disturb time zone may be enabled. Turn Do Not Disturb off or change time zone boundaries.</li> <li>• Call forwarding feature enabled or call forwarding time zone is turned on. Turn off call forwarding and call forwarding time zone. Change call forwarding time zone boundaries.</li> <li>• Voltage drop in 24 VAC supply. Check voltage at terminals 17 &amp; 18.</li> <li>• Disconnect PHON OUT wires from terminals 4 &amp; 5. Connect test telephone to terminals 4 &amp; 5. If test telephone rings, problem is with phone out wiring. If test phone does not ring, circuit board may be at fault.</li> </ul>
Phones in home ring, but no communication occurs.	<ul style="list-style-type: none"> <li>• Check telephone company demarcation (interface) device placement. 1812 must be wired so that the C.O. wires exiting the demarcation device are connected to the C.O. terminals on the bypass switch. Check the wiring diagram.</li> <li>• Disconnect the PHON OUT wires and connect a test telephone to the PHON OUT terminals (4 &amp; 5). If the 1812 cannot communicate with the test phone, PHON IN and PHON OUT wires may be connected backwards. Check wiring and reconnect.</li> </ul>
System will not activate relays. Phones do not generate a tone.	<ul style="list-style-type: none"> <li>• Switch the wires on the PHON OUT terminals (4 &amp; 5).</li> </ul>

SYMPTON	POSSIBLE SOLUTION(S)
System generates tone when granting access to a visitor, but will not work on regular phone line.	<ul style="list-style-type: none"> <li>• Switch the wires on the PHON IN terminals.</li> </ul>
System will not answer when called from the residents phone.	<ul style="list-style-type: none"> <li>• Using the wrong attention number. Re-program attention number.</li> </ul>
System will not answer when called from a remote location.	<ul style="list-style-type: none"> <li>• Auto-answer feature is turned off. Turn auto-answer feature on.</li> <li>• Number of rings to answer may be programmed too high. Reprogram number of rings to answer.</li> </ul>
Electric strike locks on or gate operator holds open.	<ul style="list-style-type: none"> <li>• Excessive voltage drop on 24 VAC line.</li> <li>• Relay auto-activate time zone enabled. Turn off auto-activate or reprogram time zone.</li> <li>• Entry code used was programmed under a hold location code. Reprogram entry code into a momentary activation location code.</li> </ul>
Entry code will not work.	<ul style="list-style-type: none"> <li>• Forgetting to press # first.</li> <li>• Entry code is programmed under a time zone restricted location code and the entry code time zone is enabled. Turn entry code time zone off, reprogram time zone boundaries or reprogram entry code under momentary activation location code.</li> <li>• Entry code is programmed under a time zone restricted location code and external time zone input (terminals 6 &amp; 9) is shorted (activated). Remove external time zone input or reprogram entry code under a momentary activation location code.</li> </ul>

## 5.2 ACCESSORIES

Slave Keypad	Allows remote activation of the system relays by use of the entry codes. Does not provide any voice communication to the main unit or to the resident telephone. P/N 1812-082.
Surge Suppressers	High voltage (115 V) suppresser. P/N 1876-010. Phone line suppresser. P/N 1877-010. Low voltage (28 V) suppresser. P/N 1878-010.
Mounting Post	Gooseneck mounting post with concrete base plate. P/N 1200-045. Gooseneck mounting post – direct burial. P/N 1200-046.
Telephone Test Set	Includes clips, cord and carrying case. P/N 1800-050.
Battery	12 volt .8 amp hour gel cell provides stand by power during power interruptions. P/N 1801-008.
Postal Lock Box	Provides a means for the mail carrier to enter the premise to deliver mail. P/N 1402-080.
CCTV Camera	Camera mounted in phone system. P/N 1812-130 Color, P/N 1812-040 Black & White.
Magnetic Locks	A variety of magnetic locks are available to meet individual application requirements. Contact your DoorKing dealer.
Electric Strikes	A variety of electric strikes are available to meet individual application requirements. Contact your DoorKing dealer.

## 5.3 TABLES

Complete the information in the tables on the following pages to maintain a record of the information that has been programmed into the telephone entry system if the system IS NOT being programmed from a PC. If PC programming is being utilized, there is no reason to maintain these log sheets since the PC will maintain a complete record of the information that has been programmed.

MASTER CODE			

Tone Open Numbers	Relay 1	Relay 2
Momentary Activation		
Continuous Activation		
Release		
Hold 1 Hour		

Do Not Disturb Time Zone	
Begin Time	
End Time	
Days of Week	

Call Forward Time Zone	
Begin Time	
End Time	
Days of Week	

4-Digit Entry Code Time Zone	
Begin Time	
End Time	
Days of Week	

Auto Relay Activation Time Zones				
	Relay 1		Relay 2	
	Zone 1	Zone 2	Zone 3	Zone 4
Begin Time				
End Time				
Days of Week				

## Entry Code Log Sheet

Location Number	Relay	Function	Entry Code	Location Number	Relay	Function	Entry Code
01	1	Momentary		26	2	Momentary	
02	1	Momentary		27	2	Momentary	
03	1	Momentary		28	2	Momentary	
04	1	Momentary		29	2	Momentary	
05	1	Momentary		30	2	Momentary	
06	1	Momentary		31	2	Momentary	
07	1	Momentary		32	2	Momentary	
08	1	Momentary		33	2	Momentary	
09	1	Momentary		34	2	Momentary	
10	1	Momentary		35	2	Momentary	
11	1	Momentary		36	2	Momentary	
12	1	Momentary		37	2	Momentary	
13	1	Momentary		38	2	Momentary	
14	1	Momentary		39	2	Momentary	
15	1	Flash		40	2	Flash	
16	1	Hold		41	2	Hold	
17	1	Hold		42	2	Hold	
18	1	Hold		43	2	Hold	
19	1	Hold		44	2	Hold	
20	1	Hold		45	2	Hold	
21	1	Time Zone		46	2	Time Zone	
22	1	Time Zone		47	2	Time Zone	
23	1	Time Zone		48	2	Time Zone	
24	1	Time Zone		49	2	Time Zone	
25	1	Time Zone		50	2	Time Zone	