

VILLA PERGOLA  
VILLA PERGOLA

Avec sa construction simple, la Villa Pergola s'assemble facilement et rapidement. L'utilisation de l'aluminium offre une durabilité à long terme tout en minimisant l'entretien.

With its simple construction, the pergola Villa assembles easily and quickly. The use of aluminum provides long term durability while minimizing maintenance.

HAUTEUR | HEIGHT 8' (250 cm)

DIMENSIONS | DIMENSIONS 10'x10' | 10'x13' | 13'x13' | 19'x13'  
 PERSIENNES | LOUVER 135 x 30 x 1.2 mm  
 POTEAUX | BEAM 127 x 127 x 2 mm

\* Les dimensions impériales sont approximatives \* Imperial dimensions are approximate

Options additionnelles:  
Additional options:

- Pergola manuelle
- Pergola automatisée
- Moustiquaire manuel
- \* • Moustiquaire automatisée
- \* • Panneau intimité
- Manual pergola
- Automated pergola
- Manual pergola screen
- Automated pergola screen
- Intimty panel

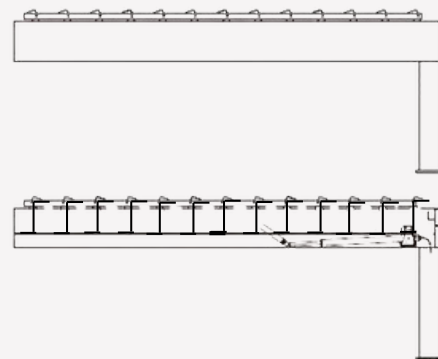

VUE DE COUPE  
SECTIONAL VIEW



BLANC - CHARBON - HYBRIDE  
WHITE - CHARCOAL - HYBRID



\* Consulter la fiche technique individuelle  
\* Consult the individual technical sheet



Courriel  
info@procamdistribution.ca

Site web  
www.procamdistribution.ca

Téléphone  
1-844-776-2266

Adresse  
780 rue Vernon Suite D  
Gatineau (Québec) J9J 3K5

**PIÈCES**  
*PIECES*

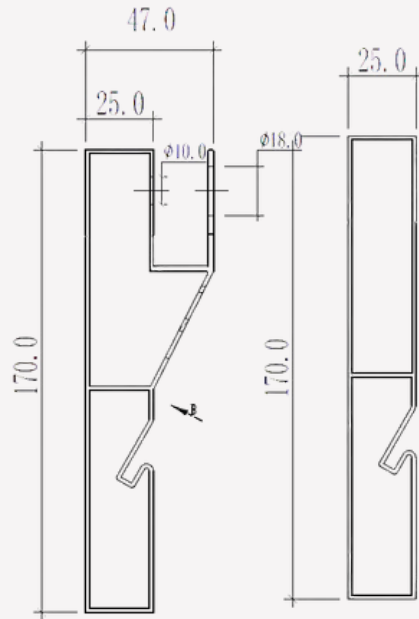

**MOTEUR TÉLÉSCOPIQUE**  
*TELESCOPIC ENGINEER*

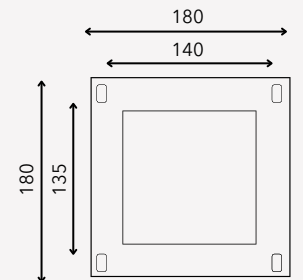
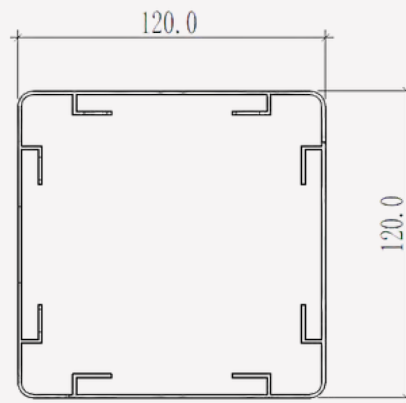
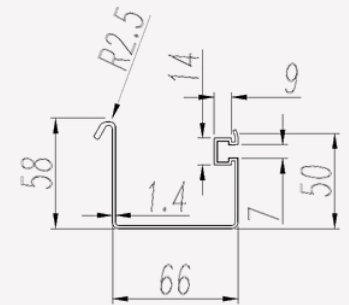

Épaisseur  $\pm 7\text{ mm}$   
Thickness  $\pm 7\text{ mm}$

**DÉTAIL PLAQUE ANCRAGE**  
*GROUND ARTICULATION DETAIL*

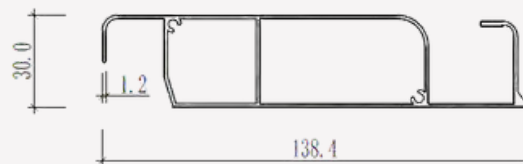

Courriel  
[info@procamdistribution.ca](mailto:info@procamdistribution.ca)

Site web  
[www.procamdistribution.ca](http://www.procamdistribution.ca)

Téléphone  
1-844-776-2266

Adresse  
780 rue Vernon Suite D  
Gatineau (Québec) J9J 3K5