

# Mini-Bar 15-16

Crowbar Circuit

Full kit

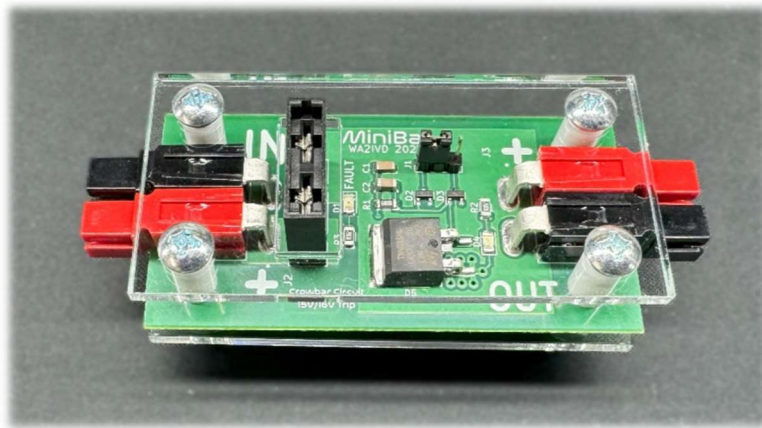

Assembly Manual

Designed by: WA2IVD

2024

A2Z Tech LLC

Thank you for purchasing the MiniBar 15-16 Full Kit!

## Introduction

The MiniBar 15-16 crow-bar circuit is designed to protect electronic equipment from damage because of over-voltage in the event of a power supply failure. It is designed for radio and electronic equipment that operates nominally at 13.8 Volts DC. The MiniBar 15-16 can be set to trip at 15 volts or 16 volts. The 15 volt setting is best when operating directly from a 13.8 volt power supply and provides the highest level of protection for electronic equipment.

The 16 volt setting can be used when operating from a vehicle 12 volt charging system or from lithium ion batteries while connected to solar or other charging equipment. Some lithium battery charging systems and automotive charging systems can operate very close to 15 volts under certain conditions. The 16 volt trip setting provides additional margin against false trips while still providing overvoltage protection for sensitive loads.

The MiniBar 15-16 includes the additional filtering to filter noise spikes that might trip the crowbar if it is plugged directly into a live power source.

Thank you for purchasing the MiniBar 15-16 crowbar circuit kit!

## Parts List

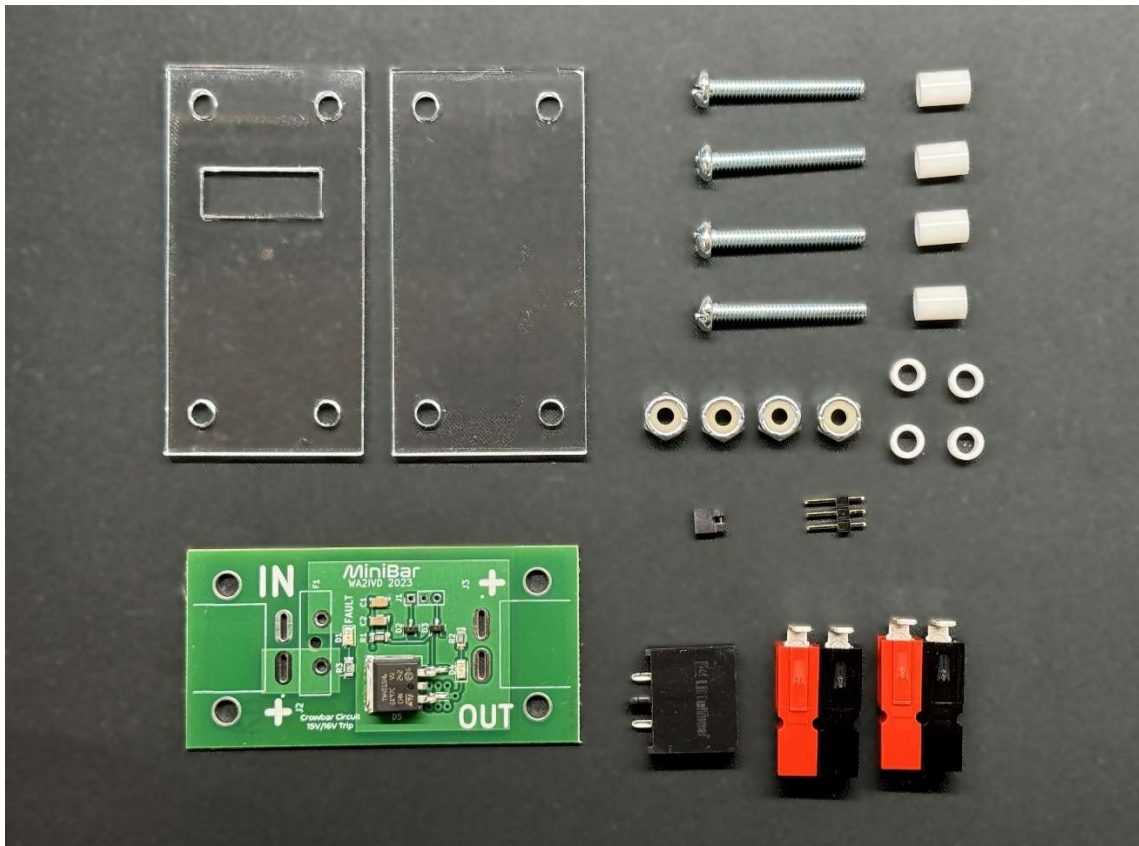

Parts List	
QTY	Description
1	PC Board w/ all SMT components placed and soldered
2	Anderson PowerPole 45Amp PCB Mount Red/Black connector
1	Littelfuse PCB Mount Automotive blade fuse holder
1	3-pin header – 0.1" (2.54mm) pin spacing
1	2-pin trip voltage selection jumper
1	Acrylic front plate (with hole for fuse holder)
1	Acrylic back plate
4	8-32 x 1-1/4 screws
4	8-32 nylon locknuts
4	#8 round 3/8" nylon spacer (for top side of circuit board)
4	#8 round 1/8" nylon spacer (for back side of circuit board)
1	Thank you / Instruction QR code card

## Circuit Details

The positive load current goes through the fuse and solid copper planes on the front side of the board. Negative load current goes through a solid copper plane on the back side of the board.

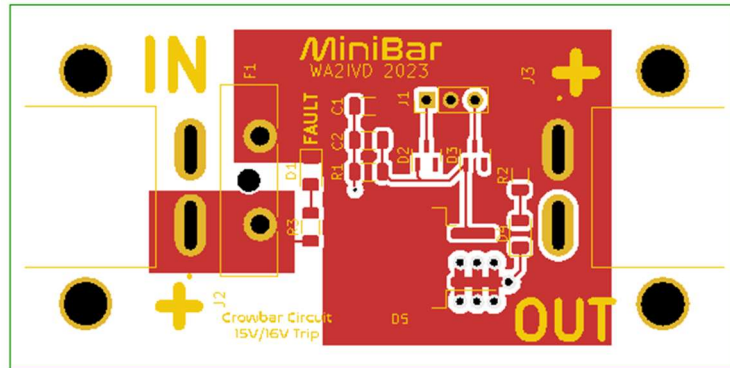

PC Board Front side Copper & Silkscreen

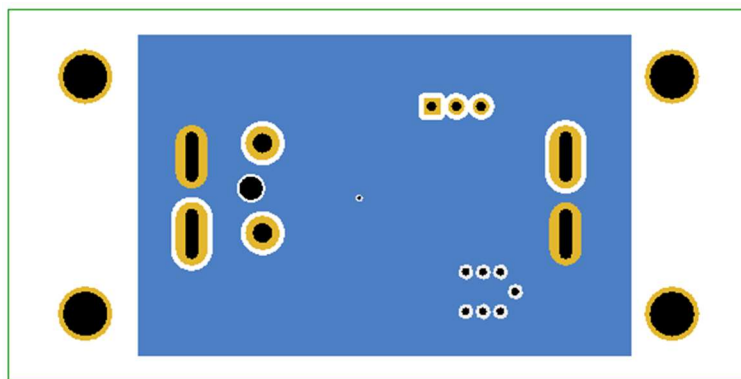

PC Board Back side Copper (viewed from front)

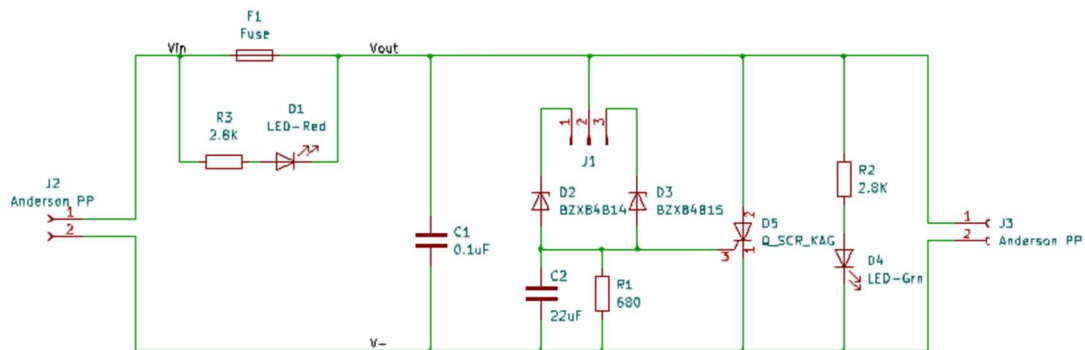

Schematic

## Assembly instructions

**Important:** You will be soldering large terminals to solid copper planes. You will need to use at least a 50-75 watt soldering iron or a temperature controlled soldering station. You should be using a large chisel tip. If you have a soldering station, set the temperature to at least 680F (360C).

It is counterintuitive, but the higher temperature actually helps to minimize the chance of damaging the PC board by heating the terminals and PC board up quickly to melt the solder faster.

- [ ] Install the 3 pin header (J1) on the board

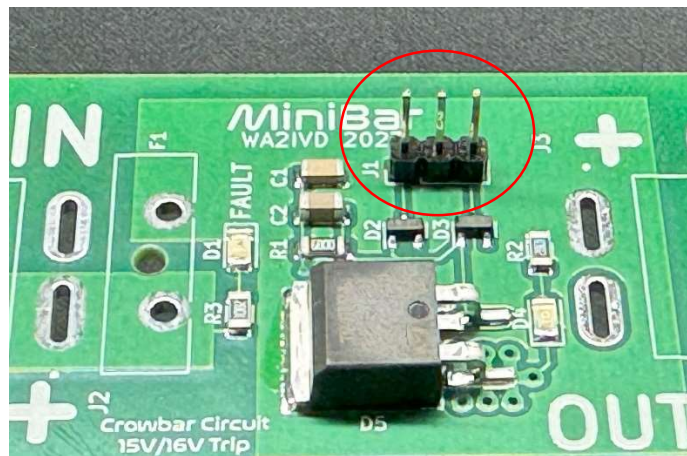

Hold the header in place while soldering ONLY ONE Pin on the back side of the board. If you don't have a Helping Hands or similar device, you can hold the header in place by placing the board upside down on your workbench.

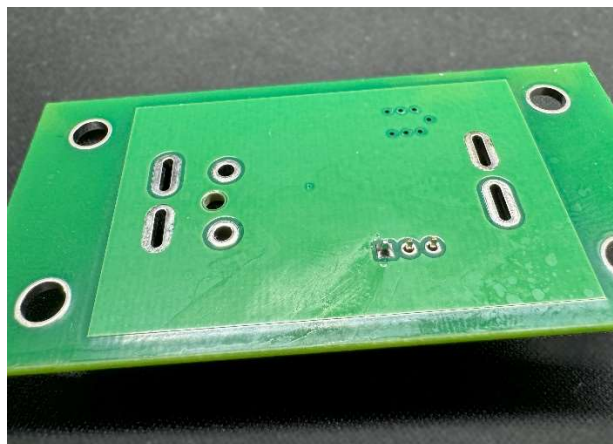

- [ ] Confirm that the header is vertical and flush to the board. You can re-melt the solder on the one pin to reposition the header. Once the header is properly placed, then solder the remaining 2 pins.

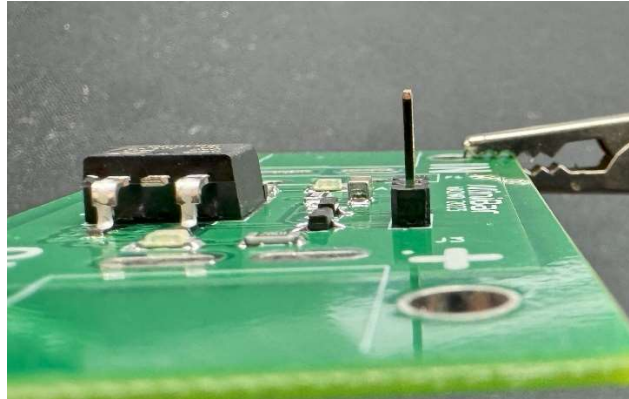

- [ ] Install the jumper to select desired trip voltage.  
Pin 1 is closest to J1 label on PC board.  
- Jumper Pins 1-2 for 15V trip  
- Jumper Pins 2-3 for 16V trip

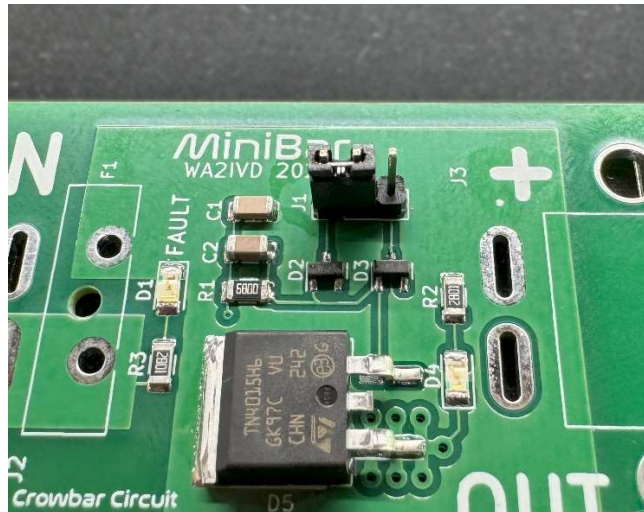

15V trip is shown



- [ ] Insert one of the Anderson PowerPole connectors into the Input or Output slots on the PC Board.

The back side of the connector (closest to the solder terminals) must be held flush to the board while it is being soldered.

If you don't have a small vise or other clamp, a large butterfly clip (found in office supply stores) can be used as a clamp to hold the connector in place while it is soldered.

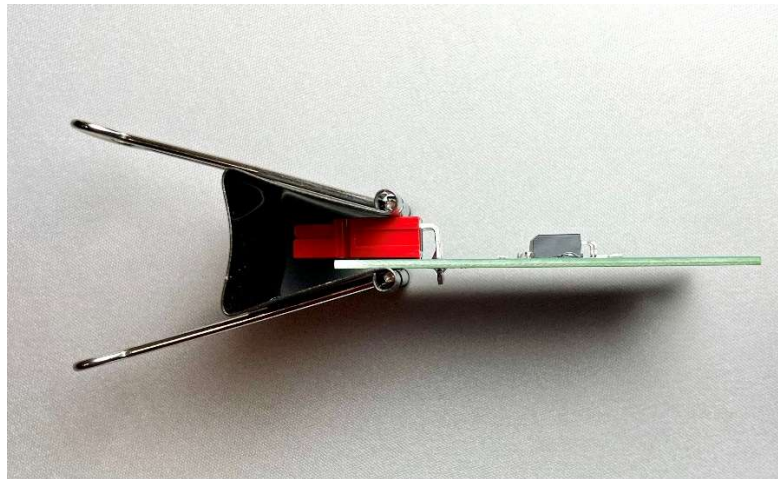

Solder the connector in place

- [ ] Insert the other Anderson PowerPole connector into Board. Be sure the connector is flush to the board and solder it in place.
- [ ] Insert the fuse holder (F1) into the PC Board. The center plastic post on the fuse holder will snap into the center hole on the board and hold it in place. Solder the fuse holder.

- [ ] Assemble the top and bottom acrylic plates using the provided screws, nuts and spacers.

The top acrylic plate is pre-cut for the fuse holder.

The smaller (1/8") spacers go between the bottom of the board and the bottom acrylic plate. The larger (3/8") spacers go between the board and the top acrylic plate.

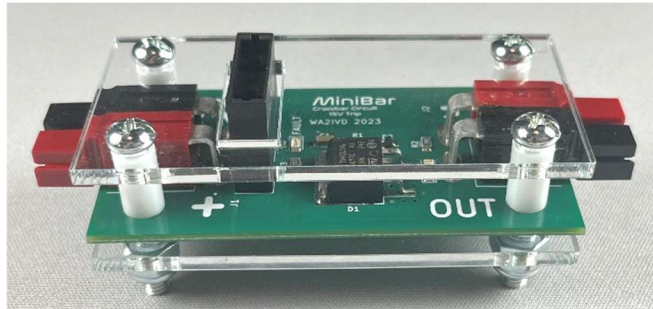



## Using the MiniBar

When power is available at the output connector, a green LED (D4) next to the output connector will be lit.

The MiniBar monitors the voltage from the power source. It will trip and put a short circuit across the input fuse if the power source voltage exceeds 15 or 16 volts, depending on the selection. Its primary purpose is to prevent the radio or other electronic load from ever seeing excessive voltage.

The actual trip voltage will vary based on operating temperature and component tolerances.

15V setting - 14.6 to 15.4 volts

16V setting – 15.6 to 16.4 volts

When the fuse has been blown, the red Fault LED (D1) next to the fuseholder will illuminate. If no load or a very small load is connected, the red Fault LED and green output LED will both light.

Capacitor C2 in the SCR gate circuit helps prevent false trips from voltage spikes when connecting to a live DC power source. However, it is still good practice to turn power off whenever possible before connecting power sources, loads, or other equipment.

Connect the IN side of the MiniBar to your power source. Connect the OUT connector of the MiniBar to your load. This might be a radio, a station accessory, or some type of power distribution box.

A fuse is not included with the MiniBar. You must select a fuse rating appropriate to the load(s) you are powering.

The maximum allowable fuse is 30 Amps.

**IMPORTANT:** Always use high-quality brand name fuses, such as Eaton-Bussmann®, Littelfuse®, or similar.

**NOTE:** The MiniBar 15-16 PC Board can handle approximately 15 Amps continuous current. For higher currents, up to 30 amps, you must operate at 50% duty cycle or less and no more than 30 seconds continuous at 30 amps. This should be adequate for operating SSB, FT8, or CW with typical 100W radios. For data modes with long transmission times such as SSTV or RTTY with lengthy text, you will need to reduce output power to approximately 50 watts or less to avoid overheating the MiniBar.

**IMPORANT:** Your power source must be able to deliver at least 2X more current than whatever fuse rating you choose. If your power source delivers less current, the fuse might not trip reliably.

If your power source cannot deliver sufficient current to blow the fuse, the MiniBar can overheat and will be damaged.