

SSV KIT - Smart-Locker Kit Maverick X3 MY17 to MY18

Part number (SKU) : 715004746

Product:	Side-by-side
Project no:	487802613
Instruction Sheet P/N:	487802613
Revision no:	
Revision date:	
Item covered:	Smart-Locker Kit Maverick X3 MY17-18

The following symbols may be used in this document:

 **WARNING**

Indicates a hazardous situation which, if not avoided, could result in death or serious injury.

 **CAUTION:** Indicates a hazard situation which, if not avoided, could result in minor or moderate injury.

NOTICE Indicates an instruction which, if not followed, could severely damage vehicle components or other property.

 **WARNING**

- For safety reasons, this kit must be installed by an authorized BRP dealer.
- This kit is designed for specific applicable models only (authorized BRP dealers will confirm model(s)). It is not recommended for units other than the one (those) for which it was sold.
- Should removal of a locking device (e.g. lock tabs, self-locking fasteners, etc.) be required when undergoing disassembly/assembly, always replace with a new one.
- Torque wrench tightening specifications must strictly be adhered to.
- Always wear EYE PROTECTION AND APPROPRIATE GLOVES when using power tools.
- Some components may be HOT. Always wait for engine to cool down before performing work.

 **WARNING**

Some important safety information and/or operating instructions dedicated to the end user might be included in this instruction sheet. Make sure to give the kit part number as well as the instruction sheet included with this kit to the customer. Verify that the customer has access to all the information required for proper use of the accessory.

NOTE: USE TIGHTENING TORQUES IN THE FOLLOWING TABLE IF NOT OTHERWISE SPECIFIED.

	GRADE			
	5.8	8.8	10.9	12.9
M4	1.8 ± 0.2 N•m (16 ± 2 lbf•in)	2.8 ± 0.2 N•m (25 ± 2 lbf•in)	3.8 ± 0.2 N•m (34 ± 2 lbf•in)	4.5 ± 0.5 N•m (40 ± 4 lbf•in)
M5	3.3 ± 0.2 N•m (29 ± 2 lbf•in)	5 ± 0.5 N•m (44 ± 4 lbf•in)	7.8 ± 0.7 N•m (69 ± 6 lbf•in)	9 ± 1 N•m (80 ± 9 lbf•in)
M6	7.5 ± 1 N•m (66 ± 9 lbf•in)	10 ± 2 N•m (89 ± 18 lbf•in)	12.8 ± 2.2 N•m (113 ± 19 lbf•in)	16 ± 2 N•m (142 ± 18 lbf•in)
M8	15.3 ± 1.7 N•m (135 ± 15 lbf•in)	24.5 ± 3.5 N•m (18 ± 3 lbf•ft)	31.5 ± 3.5 N•m (23 ± 3 lbf•ft)	40 ± 5 N•m (30 ± 4 lbf•ft)
M10	29 ± 3 N•m (21 ± 2 lbf•ft)	48 ± 6 N•m (35 ± 4 lbf•ft)	61 ± 9 N•m (45 ± 7 lbf•ft)	73 ± 7 N•m (54 ± 5 lbf•ft)
M12	52 ± 6 N•m (38 ± 4 lbf•ft)	85 ± 10 N•m (63 ± 7 lbf•ft)	105 ± 15 N•m (77 ± 11 lbf•ft)	128 ± 17 N•m (94 ± 13 lbf•ft)
M14	85 ± 10 N•m (63 ± 7 lbf•ft)	135 ± 15 N•m (100 ± 11 lbf•ft)	170 ± 20 N•m (125 ± 15 lbf•ft)	200 ± 25 N•m (148 ± 18 lbf•ft)
M16	126 ± 14 N•m (93 ± 10 lbf•ft)	205 ± 25 N•m (151 ± 18 lbf•ft)	255 ± 30 N•m (188 ± 22 lbf•ft)	305 ± 35 N•m (225 ± 26 lbf•ft)
M18	170 ± 20 N•m (125 ± 15 lbf•ft)	273 ± 32 N•m (201 ± 24 lbf•ft)	330 ± 25 N•m (243 ± 18 lbf•ft)	413 ± 47 N•m (305 ± 35 lbf•ft)

The illustrations in this document show typical construction of the different assemblies and may not reproduce the full detail or exact shape of the parts; however, they represent parts that have the same or similar function.

In the pictures below, parts may have been removed for clarity purposes.

Installation time is approximately 3.0 hour.

PARTS TO BE INSTALLED

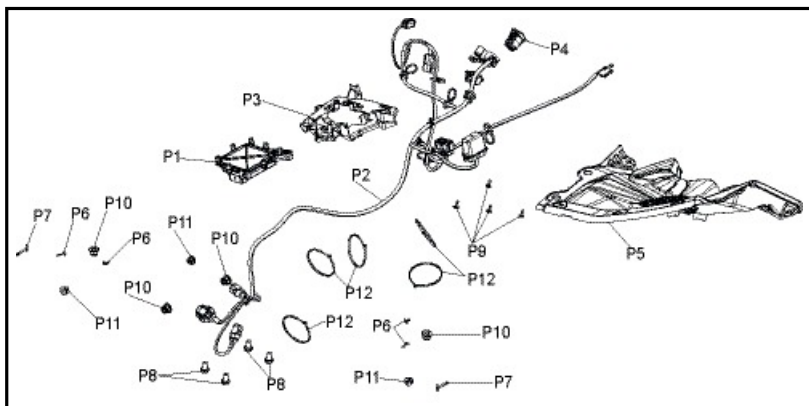

ITEM	DESCRIPTION	Part number	QTY
P1	FDM module	710006479	1
P2	Front differential wiring harness	710005778	1
P3	FDM support	710005807	1
P4	4x4 Differential switch	710006040	1
P5	LH dash	707900646	1
P6	Cotter pin	211400017	4
P7	Cotter pin	250400084	2
P8	M10 x 20 Flanged screw	207502046	4
P9	PT type K-50 x 16 Screw	250000959	4
P10	M12 Elastic flanged nut	233221466	4
P11	M10 Elastic flanged nut	233201416	3
P12	368mm Locking tie	293750008	15

INSTRUCTIONS

Vehicle preparation

1. Disconnect the battery.

NOTICE Always disconnect battery before doing any electrical modifications. Do not place tools on battery. Proceed exactly in this specific order:

- Disconnect black cable (-) first.
- Disconnect red cable (+) after.

Differential installation

1. Drain the differential. Refer to *PERIODIC MAINTENANCE PROCEDURES* subsection in the shop manual.
2. Remove both drive shafts. Refer to *FRONT DRIVE* subsection in the shop manual.
3. Remove the RH upper suspension arm. Refer to *FRONT SUSPENSION* subsection in the shop manual.
4. Remove the propeller shaft from the differential.
5. Remove the four retaining screws from the bottom skid plate.

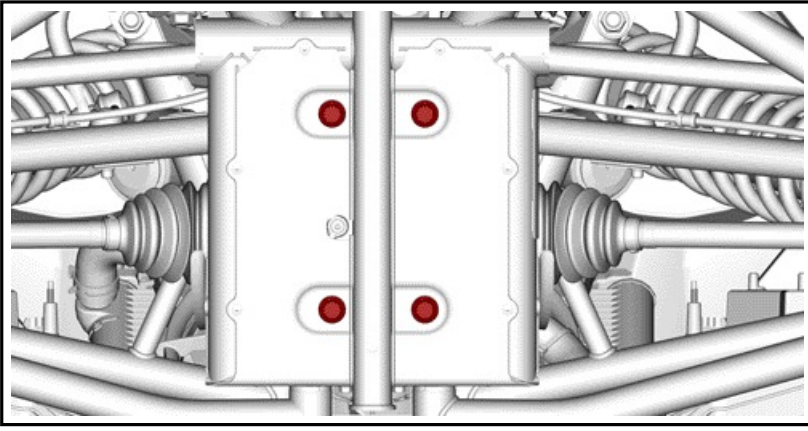

6. Remove the differential from the RH side of vehicle.
7. Install the new Smart-Lok differential and fix it with the four new bolts in this kit.
8. Install the new differential with associated half-shafts (sold separately) and reinstall all previously removed parts with provided hardware.

Harness installation

1. If equipped, move up the windshield washer tank to pass the wires in the rubber deflector.
2. Insert the three connectors of the differential in the rubber deflector.

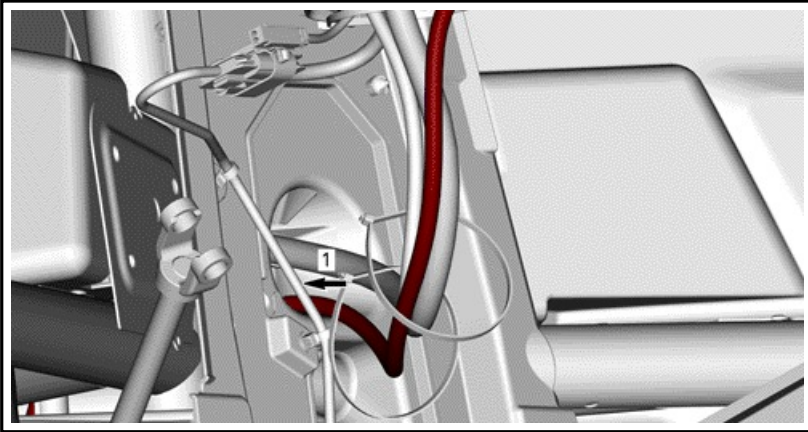

3. Follow the electric harness of the vehicle to the differential harness and connect the three connectors to the differential.

NOTE: A connector is identified with a yellow tape to avoid confusion and ensure proper wiring.

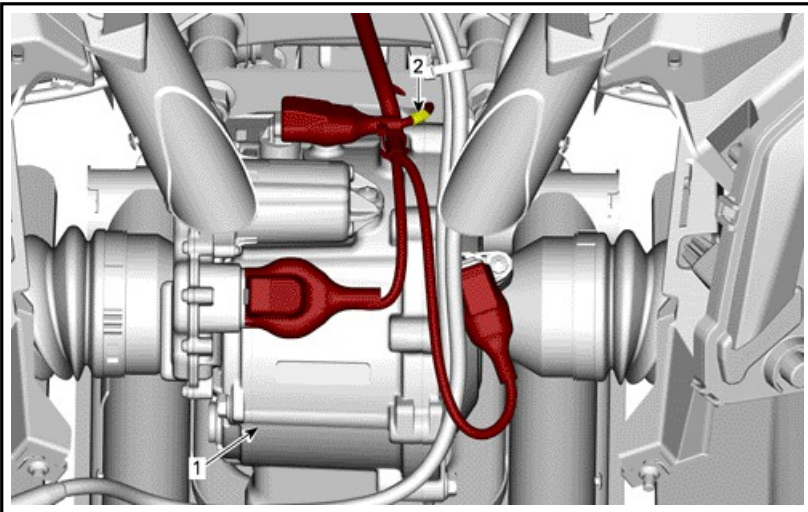

1. Differential
2. Yellow tape

4. Disconnect and discard the factory installed 4x4 switch. Take the loose 4x4 connector on the vehicle harness and plug it into the Smart-Lok harness at this location.

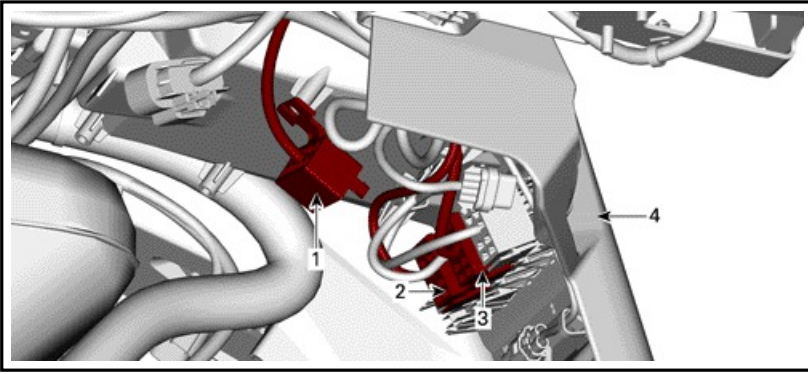

1. Connect the vehicle 4x4 selector connector into the Smart-Lok harness
2. Smart -Lok 4x4 mode selector switch connector (switch sold separately)
3. Smart-Lok harness 4x4 connector
4. Console

5. The provided harness [P2] has two connector housings. install the 4x4 switch [P4] to the connector without yellow tape. The loose connector will be used by the differential mode switch (sold separately).

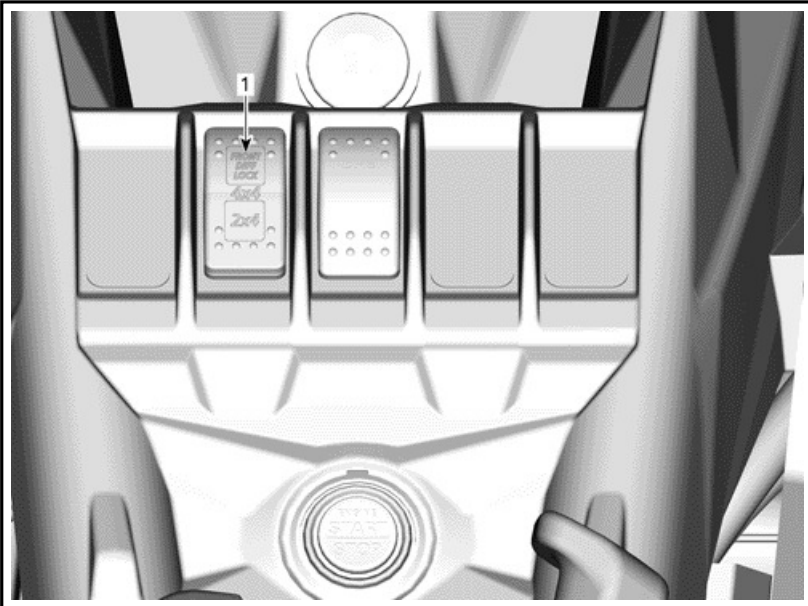

1. 4x4 switch

6. Connect the 4x4 Differential switch [P4]. Connect the 4x4 mode selector switch in the designated connector identified by a yellow tape on the harness (sold separately).

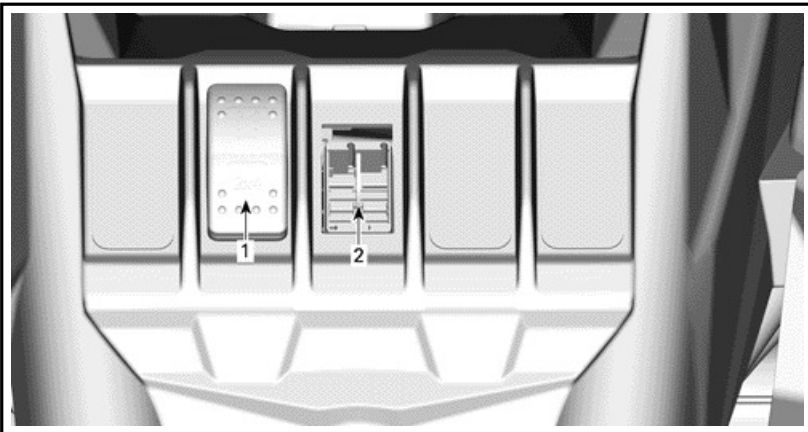

1. 4x4 Differential switch [P4] location
2. 4x4 mode selector switch location

7. Remove the passenger side console panel. Refer to shop manual.

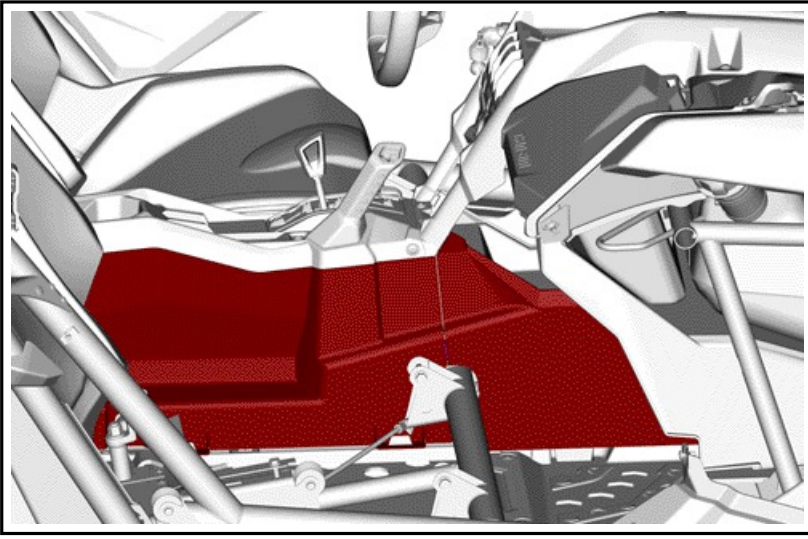

8. Connect the positive wire and the negative wire to the junction block. Refer to shop manual.

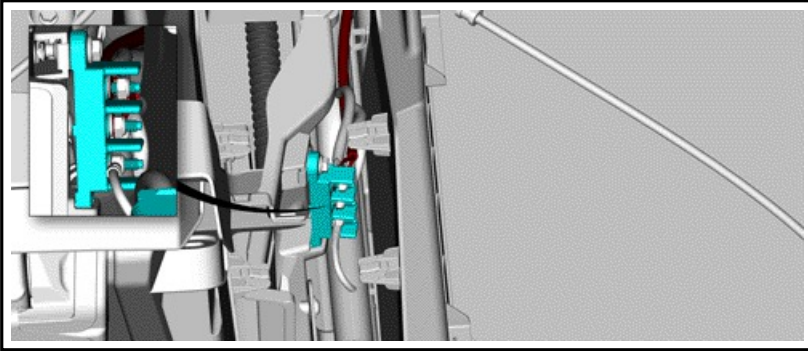

9. Disconnect the diagnostic connector in the glove compartment.

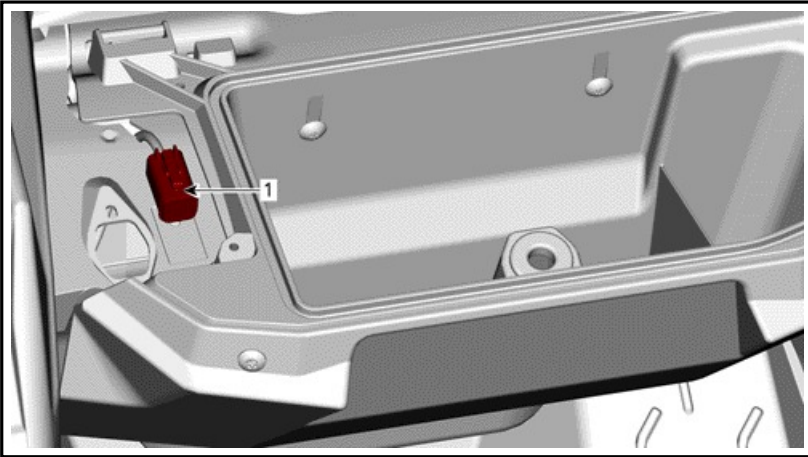

1. Diagnostic connector

10. Connect the diagnostic cable of the vehicle in the female connector of the Smart-Lok harness. Position the diagnostic cable of the Smart-Lok harness at the original location in the glove compartment.

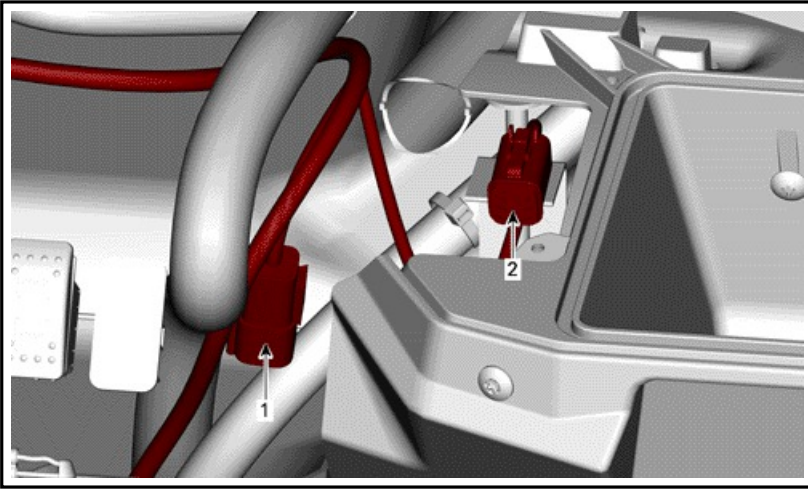

1. Female connector of the Smart-Lok harness
2. Diagnostic connector original location

Module installation

1. Remove all installed switches on the dash.
2. Remove the seven screws and the two Tuflok plastic rivet retaining the dash.

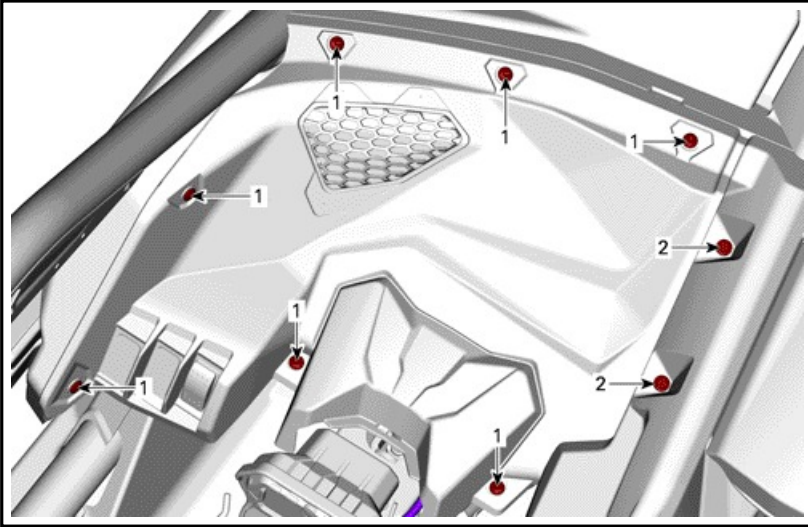

1. Screw
2. Tuflok plastic rivet

3. Remove the clip holding the dash and remove the dash.

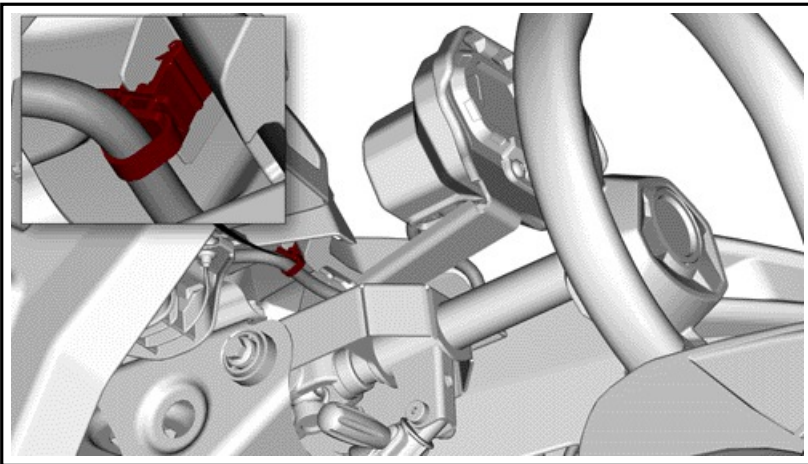

4. Remove the speaker hole trim from the vehicle dash and reinstall it on the new dash [P5].

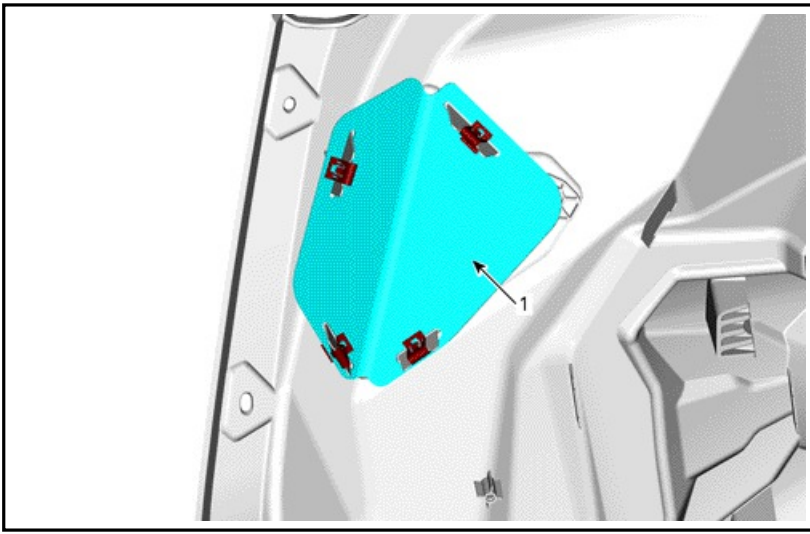

1. Speaker hole trim

5. Press on the FDM module [P1] to clip on the FDM support [P3].

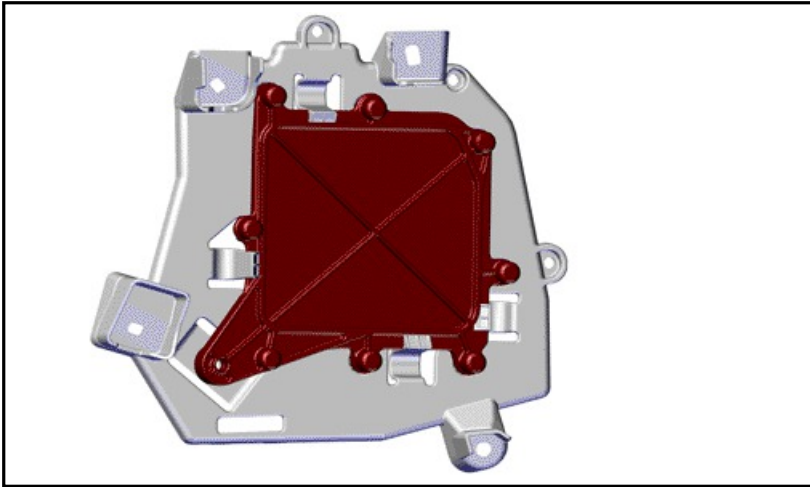

6. Install the FDM support [P3] on the LH dash [P5] with four PT type K-50 x 16 Screw [P9].

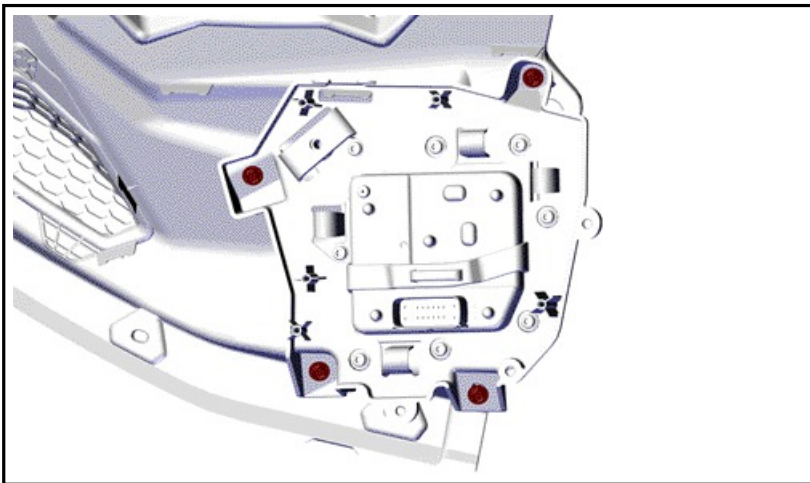

Tightening torque

PT type K-50 x 16 Screw [P9]

6 to 6.5 N•m (53 to 58 lbf•in)

7. Install the LH dash [P5]. The installation is the reverse of the removal procedure.

8. Connect the connector of the FDM module [P1] and fix the fuse holder on the FDM support [P3].

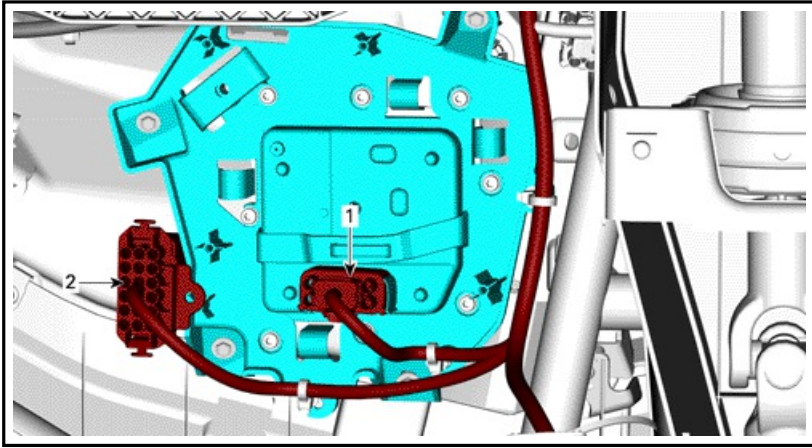

- 1. Connector of the FDM module
- 2. Fuse holder

- 9. Secure all wires using locking ties [P12].
- 10. Reconnect the battery.

NOTICE Connect RED cable (+) first then BLACK cable (-).

- 11. Turn on the vehicle.
- 12. Verify on the multifunction dial for any error message.
- 13. Put the switch in 4x4 position. The switch should lit up.
- 14. Verify on the multifunction dial for any new error message.
- 15. If the switch doesn't light up:
 - 15.1 Turn off the vehicle.
 - 15.2 Verify all connections (module, switches, differential, power, etc.)
 - 15.3 Turn the vehicle back on.
 - 15.4 Repeat step 11 and 12. If switch doesn't turn on, contact your local BRP dealer fore a more in-depth troubleshooting.

NOTICE Make sure power harness does not come into contact with any sharp edge, mobile parts and hot surfaces before securing it in place.
