

QUICKTRONIC® PROStart® CF Universal Dual Entry Systems

<10% THD Electronic T4 Compact Fluorescent
Programmed Rapid Start Systems
Normal Ballast Factor



Professional Series

CF DUAL ENTRY

Lamp / Ballast Guide

Primary Systems

13W T4 – DULUX D/E, T/E lamps
1-lamp or 2-lamp QTP1/2x13CF/UNV

18W T4 – DULUX D/E, T/E lamps
1-lamp or 2-lamp QTP1/2x18CF/UNV

26W T4 – DULUX D/E, T/E lamps
1-lamp QTP2x26CF/UNV
2-lamp QTP2x26CF/UNV

32 or 42W T4 – DULUX T/E lamps
1-lamp QTP2x26CF/UNV
2-lamp QTP2x26/32/42CF/UNV

57W or 70W T4 – DULUX T/E lamp
1-lamp QTP2x26/32/42CF/UNV

For other lamp types, refer to the Performance Guide section on the next page.

SYLVANIA QUICKTRONIC PROStart CF ballasts operate DULUX® D/E and T/E lamps with full lumen output and optimal system performance.

QUICKTRONIC CF ballasts feature one mounting style of low profile, lightweight enclosures to provide simple assembly for any fixture application.

Universal input voltage (120–277V) and multi-lamp multi-watt capability allow for fewer SKUs to support a wide range of applications.

Dual entry, color coded connectors located on the side and bottom allow for increased mounting flexibility with one ballast and also increased ease of installation.

These ballasts are RoHS compliant and feature lead-free solder, printed circuit boards and manufacturing process.

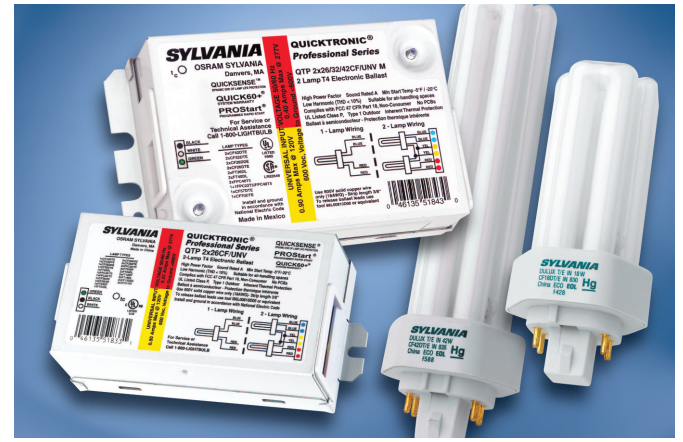

Setting the standard for quality, QUICKTRONIC PROStart CF Systems are covered by our QUICK 60+® warranty, the first and most comprehensive system warranty in the industry.

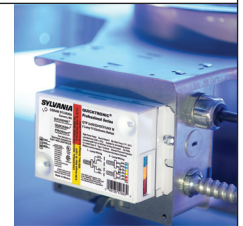

Key System Features

- Universal Input Voltage (120-277V)
- Dual entry, color coded connectors
- PROStart Ballasts program rapid start
- QUICKSENSE ballast technology
- High Power Factor
- Low Harmonic Distortion
- Small size and lightweight
- Metal enclosure
- UL, CSA, FCC
- QUICK 60+ warranty
- RoHS compliant
- Lead-free solder, printed circuit board and manufacturing process

System Information

PROStart programmed rapid start is the optimum starting method, providing up to 100,000 switching cycles for use on occupancy sensors and building control systems.

QUICKSENSE® end of lamp life sensing technology helps to protect against overheated bases and sockets, as well as cracking of the glass wall. QUICKSENSE ballast technology uses dynamic end-of-lamp-life sensing to avoid false shutdowns caused by some static sensing methods and will auto-reset when the end-of-life lamps are replaced with new ones.

QUICKTRONIC CF ballasts come with wire-trap connectors for quick and easy installation.

A complete OSRAM SYLVANIA System Performance Guide showing performance characteristics of lamps and ballasts is available upon request.

Application Information

SYLVANIA QUICKTRONIC CF ballasts

are ideally suited for:

- Recessed downlights
- Wall sconces
- Ceiling fixtures
- Commercial
- Retail, hospitality, institutional

Small Metal Case

Dual Entry Metal with and without PEM Studs
Side & Bottom Mount Capabilities



QTP2x26/32/42CF/UNV Metal Case Models

Dual Entry Metal with and without PEM Studs
Side & Bottom Mount Capabilities



SPECIFICATION DATA

Catalog #	Date	Type
Project	Prepared by	
Comments		

Universal Voltage (120-277V)



Item Number	Description ¹	Input Current (AMPS)	Lamp ¹ Type	Rated ² Lumens (lm)	No. of Lamps	Ballast Factor (BF)	System Lumens	Mean Lumens	Input Power (Watts)	System Efficacy (lm/W)	BEF ⁴
51818	QTP 1/2x13CF/UNV DM	0.25/0.11	13W DD/E,T/E	900	1	1.00	900	775	16	56	6.25
			13W DD/E,T/E	900	2	1.00	1800	1550	29	62	3.45
51823	QTP 1/2x18CF/UNV DM	0.32/0.14	18W DD/E,T/E	1200	1	1.00	1200	1030	20	60	5.00
			18W DD/E,T/E	1200	2	1.00	2400	2065	38	63	2.63
51833 51898	QTP 2x26CF/UNV DM QTP 2x26CF/UNV DM PEM	0.50/0.22	26W DD/E,T/E	1800	1	1.00	1800	1550	28	64	3.57
			26W DD/E,T/E	1800	2	1.00	3600	3095	54	67	1.85
			32W DT/E	2400	1	0.98	2350	2025	35	67	2.80
			42W DT/E	3200	1	0.96	3070	2640	45	68	2.13
51843 51863	QTP 2x26/32/42CF/UNV DM QTP 2x26/32/42CF/UNV DM PEM	0.90/0.40 0.53/0.23 0.57/0.25	26W DT/E	1800	2	1.02	3670	3155	54	68	1.89
			32W DT/E	2400	2	0.96	4610	3965	69	67	1.39
			42W DT/E	3200	2	0.95	6080	5230	94	65	1.01
			57W DT/E	4300	1	1.00	4300	3700	62	69	1.61
			70W DT/E	5200	1	0.92	4780	4115	71	67	1.30

1: Also compatible with other manufacturers' equivalent 4 pin lamp types that meet ANSI specifications.
 2: Rated lamp lumens and performance data based on DULUX T/E series 4 pin lamps.
 3: Data is for all models within the brackets. The maximum input current is shown for maximum input power.
 4: Ballast Efficiency Factor (BEF) shown = (Ballast Factor x 100) divided by Input Power (Note: calculation based on lowest wattage value).

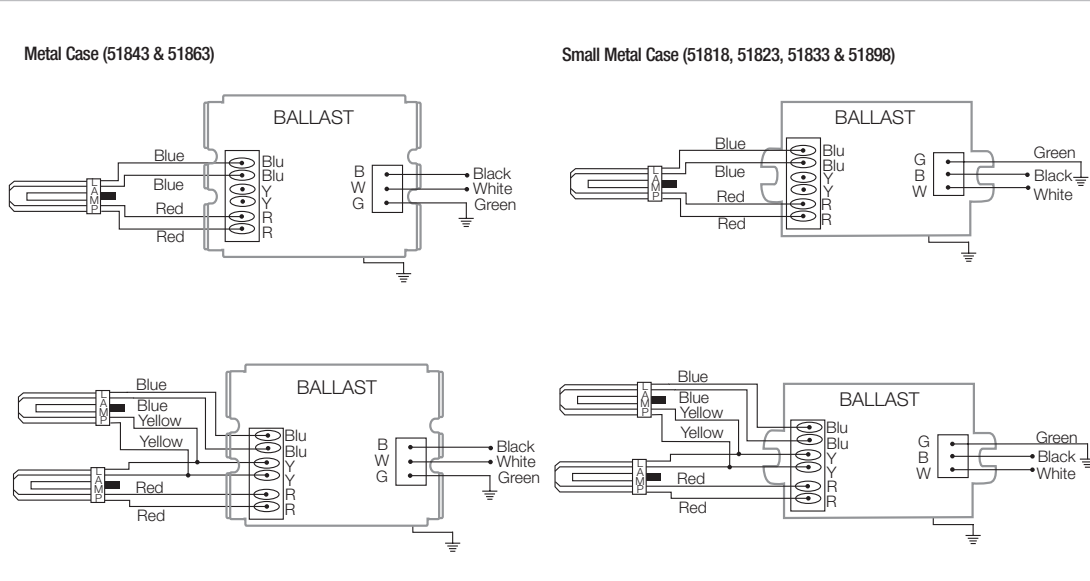

Dimensions:
 Metal case (51843 & 51863): 4.95" L x 2.93" W x 1.35" H
 Small Metal case (51818, 51823, 51833 & 51898): 4.95" L x 2.37" W x 1.10" H
 Mounting: Utilize flanges (4.57" L), or (2) #8-32 x 0.375" Long PEM studs on 2" centers

Packaging:
 Quantity: 20 pieces per case
 16 pieces per case for Item Number 51898
 18 pieces per case for Item Number 51863
 Weight: 0.40 lbs ea. (Small Metal case)
 0.90 lbs ea. (Metal case)

Wiring:
 Push-in connectors (no leads provided)
 Use 18AWG solid copper wire only

Item Number	51843 QTP 2 x 26/32/42 CF / UNV DM	Case Type (Dual Mount)
QUICKTRONIC PROFESSIONAL		Line Voltage (120-277V)
Number of Lamps (1, 2)		Primary Lamp Wattage

Normal Ballast Factor

CF Universal

Professional Series

Performance Guide

QTP 2x26CF/UNV models also operates:
 1-lamp: CF28/2D, CF38/2D, FPC40/T5, FT40DL
 1- or 2-lamp: FPC22/T5, FT24DL, FT24DF
 2-lamp: CF13DSE, FT18DL, FT18DF, CF21/2D
 QTP 2x26/32/42CF/UNV models also operates:
 2-lamp: FT36DL, FT40DL, FPC40T5
 1+1: FPC22/T5 / FPC40T5

CF DUAL ENTRY

Specifications

Starting Method: Programmed Rapid Start
Circuit Type: Series
Lamp Frequency: >40kHz
Lamp CCF: Less than 1.7
Starting Temp: -5°F/-20°C min.⁵
Input Frequency: 50/60 Hz
Low THD: <10%
Power Factor: >98%
Voltage Range: ±10% of 120-277V rated line (108-305V)

UL Listed Class P, Type 1 Outdoor
 CSA or C/UL Certified
 75°C Max Case Temp. (5 yr. warranty)
 80°C Max Case Temp. (3 yr. warranty)
 FCC 47CFR Part 18 Non-Consumer
 Sound Rated A
 RoHS Compliant⁶
 ANSI C62.41 Cat. A Transient Protection
 Dynamic End-of-Lamp-Life Sensing
 Remote Mounting (Max. wire length from ballast case to lampholder): up to 15 feet for one lamp and up to 6 feet for two lamp.

⁵ Operation below 50°F (10°C) may affect light output or lamp operation – see Low Temperature Starting definition.
⁶ Complies with European Union Restriction of Hazardous Substances Directive (Directive EC 2002/95)

System Life / Warranty

QUICKTRONIC products are covered by the QUICK 60+[®] warranty, a comprehensive lamp and ballast system warranty. For additional details, refer to the QUICK 60+ warranty bulletin.

OSRAM SYLVANIA
National Customer Service and Sales Center
 1-800-LIGHTBULB
 (1-800-544-4828)
 www.sylvania.com

Specifications subject to change without notice.