

Real Pet Food Company - Procedure Manual		
Pollution Incident Response Management Plan		
Page: 1 of 23	Issue: 9	Procedure: 280 App B

1. Introduction

1.1 Key Aspects of the Pollution Incident Response Management Plan

This Pollution Incident Response Management Plan (PIRMP) covers the key actions to minimise the occurrence of a pollution incident and manage a pollution incident if one occurs (during and after a pollution incident).

This document has been prepared for managing the impact to human health (employees and nearby neighbours) and the environment (onsite and offsite).

1.2 Background to Real Pet Food Company (RPFCo) Ingleburn

Real Pet Food Company has a manufacturing plant located on Williamson Road in the strategically zoned industrial area of Ingleburn NSW. The Plant holds an EPA licence #5061, which cover all activities undertaken on the premises

The facility manufactures a variety of wet based pet food for dogs and cats sold to both domestic and international markets.

1.3 Legislative requirement

The specific requirements for the PIRMP are set out in part 5.7A of the Protection of the Environment Operations Act 1997 (POEO Act) and the Protection of the Environment Operations (General) Regulation 2009 (POEO (G) Regulation). In summary, this provision requires the following:

All holders of environment protection licences must prepare a pollution incident response management plan (section 153A, POEO Act)

The plan must include the information detailed in the POEO Act (section 153C) and be in the form requirement by the POEO(G) Regulation (clause 98B)

Licensees must keep the plan at the premises to which the environment protection license relates or, in the case of trackable waste transporters and mobile plant, where the relevant activity takes places (section 153D, POEO Act).

Licensees must test the plan in accordance with the POEO(G) Regulation (clause 98E)

If a pollution incident occurs in the course of an activity so that material harm to the environment is caused or threatened, licensees must immediately implement the plan (section 153F, POEO Act)

2. Structure of PIRMP

Table outline the structure of the PIRMP, as per the requirements of the POEO(G) Regulation

Clause #	Requirement	Section in Plan
153A	Duty of licence holder to prepare a PIRMP	Whole document
153 C (a)	Procedures followed in notifying <ul style="list-style-type: none"> i) Owners or occupiers of premises in the vicinity of the premises ii) local authority iii) persons or authorities required to be notified 	Section 5 Section 10
153 C (b)	Detailed description of actions to be taken after pollution incidents to reduce or control pollution	Section 6
153 C (c)	Procedures for coordinating action and communication	Section 5
153 D	Keeping of plan	Section 1
153 E	Testing of plan	Section 11
153 F	Implementation of plan	Section 4
98 C (1) (a)	Description of the hazard to human health or the environment associated with the activity to which the licence relates (the relevant activity)	Section 6
98 C (1) (b)	The likelihood of any such hazards occurring, including details of any conditions or events that could, or would, increase that likelihood	Section 6
98 C (1) (c)	Details of the pre-emptive action to be taken to minimise or prevent any risk of harm to human health or the environment arising out of the relevant activity	Section 6
98 C (1) (d)	An inventory of potential pollutants on the premises or used in carrying out the relevant activity	Section 7
98 C (1) (e)	The maximum quantity of any pollutant that is likely to be stored or held at particular locations (including underground tanks) at or on the premises to which the license relates	Section 7
98 C (1) (f)	A description of the safety equipment or other devices that are used to minimise the risk to human health or the environment and to contain or control a pollution incident	Section 8
98 C (1) (g)	The names, positions and 24-hour contact details of those key individuals who: <ul style="list-style-type: none"> i. Are responsible for activating the plan ii. Are authorised to notify relevant authorities under section 148 of the Act iii. Are responsible for managing the response to a pollution incident 	Section 10.1
98 C (1) (h)	The contact details of each relevant authority referred to in section 148 of the Act	Section 10.2
98 C (1) (i)	Details of the mechanisms for providing early warnings and regular updates to the owners and occupiers of premises in the vicinity of the premises to which the license relates or where the scheduled activity is carried on	Section 5.1 Section 6 Section 10
98 C (1) (j)	The arrangements for minimising the risk of harm to any persons who are on the premises or who are present where the scheduled activity is being carried on	Section 9
98 C (1) (k)	A detailed map (or set of maps) showing the location of the premises to which the licence relates, the surrounding area that is likely to be affected by a pollution incident, the location of potential pollutants on the premises and the location of any storm water drains on the premises	Section 3
98 C (1) (l)	A detailed description of how any identified risk of harm to human health will be reduced, including (as a minimum) by means of early warnings,	Section 6 Section 5

	updates and the action to be taken during or immediately after a pollution incident to reduce that risk	Section 10
98 C (1) (m)	The nature and objectives of any staff training program in relation to the plan	Section 11
98 C (1) (n)	The dates on which the plan has been tested and the name of the person who carried out the test	Section 11.3 As per Internal audit schedule
98 C (1) (o)	The date on which the plan is updated	Base document
98 C (1) (p)	The manner in which the plan is to be tested	Section 11, mock as per Internal audit schedule

3. SITE INFORMATION

2.1 Site Details

The site is a 2.383 hectare area, located at 12 Williamson Road, Ingleburn NSW Australia

2.2 Immediate Neighbours

RPFCo has two immediate neighbours;

EAST – Vacant spillway – Bow Bowing Bunbury Curran creek system which flows into Georges River

NORTH – Higher than chemical storage company Univar

WEST - Williamson Road, main road with 2 lanes each way and large median strip

SOUTH - Slightly below metal fabrication company Steel force and PET plastic packaging manufacturer Visy

2.3 Site Aerial Photo



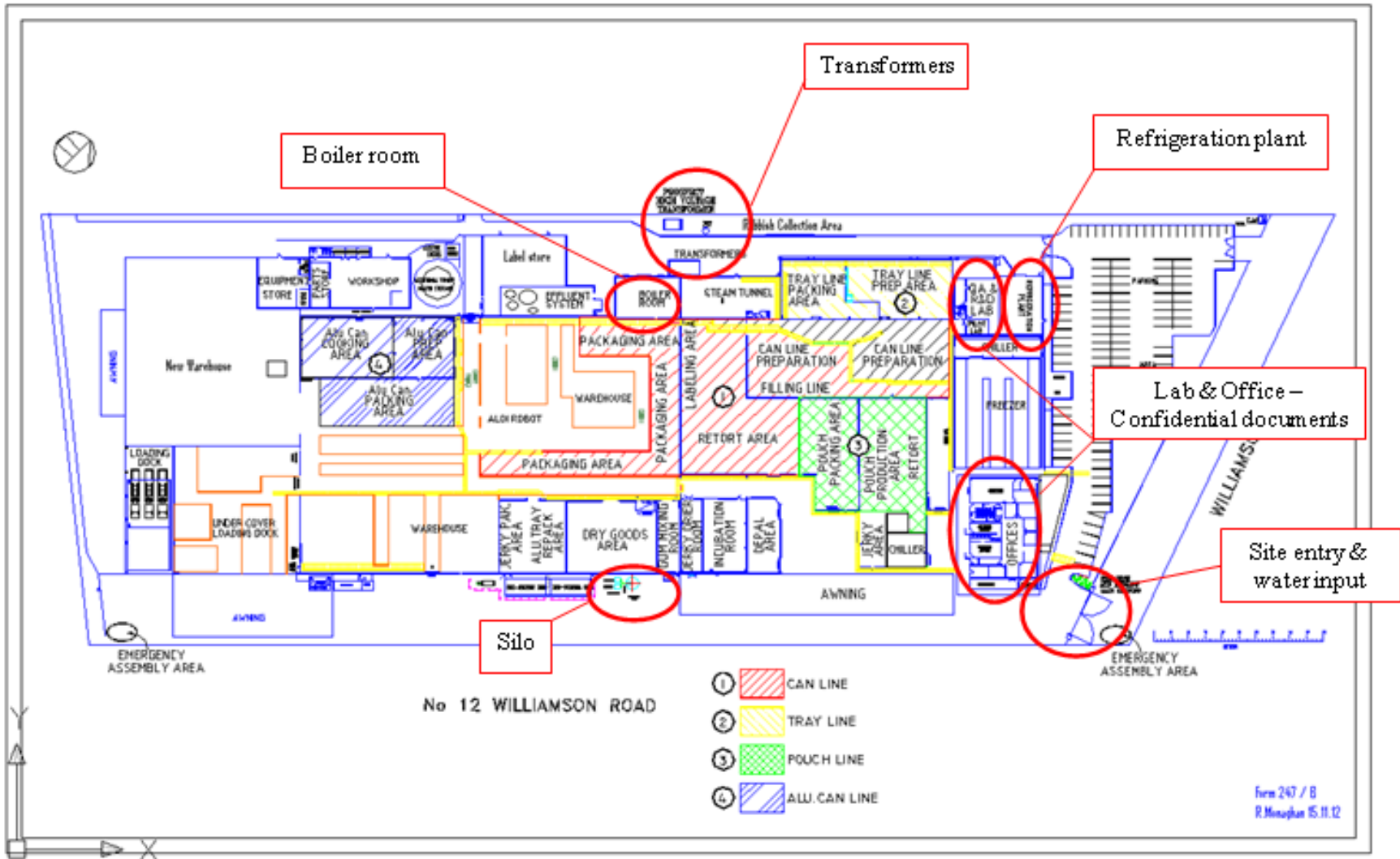

2.4 Site Map A

2.4 Site Map B

Australian Pet Brands Emergency Response

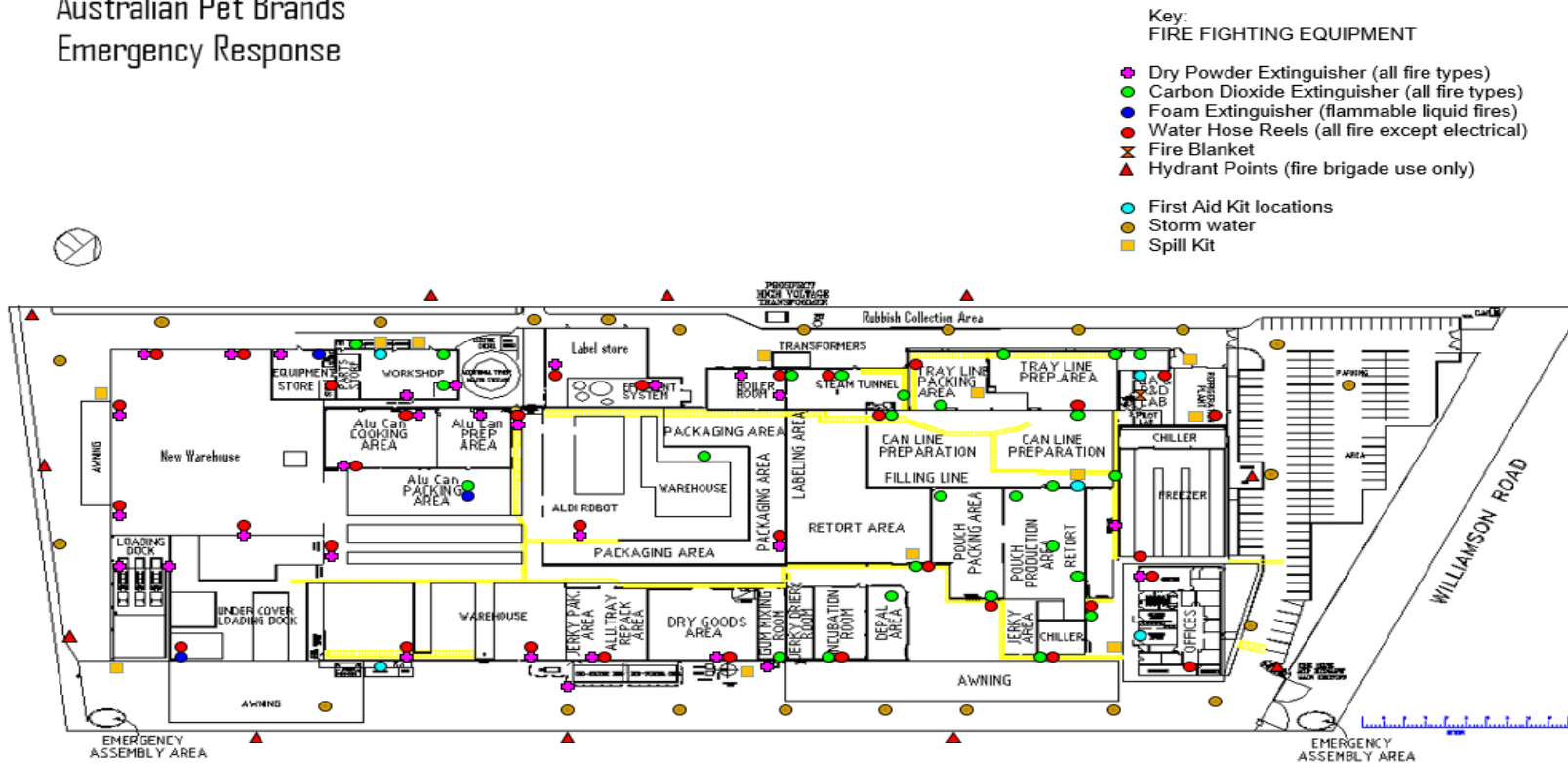

Form 247 / C
D. Yang 30.10.19

Real Pet Food Company - Procedure Manual		
Pollution Incident Response Management Plan		
Page: 7 of 23	Issue: 9	Procedure: 280 App B

4. Definition of a Pollution Incident

Under the legislation, the PIRMP is to clearly document pollution risks, communication procedures to authorities and community regarding pollution incidents, and testing and training for pollution response.

A pollution incident is required to be notified if there is a risk of 'material harm to the environment', which is defined in *section 147 of the POEO Act* as:

- (a) *Harm to the environment is material if:*
 - (i) *It involves actual or potential harm to the health or safety of human beings or to ecosystems that is not trivial, or*
 - (ii) *it results in actual or potential loss or property damage of an amount, or amounts in aggregate, exceeding \$10,000 (or such other amount as is prescribed by the regulations), and*
- (b) *loss includes the reasonable costs and expenses that would be incurred in taking all reasonable and practicable measures to prevent, mitigate or make good harm to the environment.*

If there is a pollution incident involving material harm or threatened material harm to human health or the environment, RPFC (Ingleburn) will implement this PIRMP.

Real Pet Food Company - Procedure Manual		
Pollution Incident Response Management Plan		
Page: 8 of 23	Issue: 9	Procedure: 280 App B

5. Notification of an Incident & Actions

a) Identification and escalation

Employees are instructed to report any environment, safety or property incidents to their shift manager, and to utilise press buttons to activate the emergency alarm when required.

There are also automatic triggers for the initiation of the alarm process (fire detectors). Procedure 280 – Emergency preparedness details the sites alarm and evacuation process. This includes audible alarms and provision of dedicated evacuation areas. Also included are processes such as conducting roll calls to account for personnel, search processes and facilitating interaction with emergency services departments.

If an environmental incident occurs that is a potentially notifiable pollution even it is escalated to the Site Operations Manager. The Site Operations Manager consults any relevant sites staff and co-ordinated the involvement of corporate staff to assess if a notifiable pollution incident has occurred. In the event the Site Operations Manager is not onsite the deputy will be the Shift Manager who will communicated with the Site Operations Manager until available onsite

In the event of an environmental incident occurring at the site, impacts on the neighbouring business and local community will be variable and depend on location, volume of spill or other factors such as wind direction and velocity. If an environmental incident on site is likely to impact neighbouring business or the local community, surrounding neighbours will be contacted by face to face, by telephone or through information left at the place of residence by the Site Operations Manager and/or their representative to notify them of the situation.

This notification should include any possible impacts to the neighbours as well as the procedures that have been put in place to rectify the situation. Communication methods will be used on a case by case basis, but in all situations RPFCo will attempt to provide early warnings to those neighbours likely to be directly affected. Early warnings would typically include details of the nature of the incident and how those likely to be affected can best prepare and respond to the incident. On going communication with neighbouring business/residents will be maintained until such time as the incident is rectified

b) External notification

The emergency process includes an alarm system. Activation of this system results in automatic notification of NSW Fire Services. It also encompasses and audible alarm / PA notification system

If it is determined that a notifiable environmental incident has occurred the Site Operations Manager will assign responsibility to execute the immediate notification and communication as required under section 148 POEO Act, to all the Appropriate Regulatory Authorities (ARA) and external parties. These include:

- Environment Protection Authority (EPA);
- Ministry of Health
- SafeWork NSW
- Local council;
- Fire and Rescue NSW; and
- Surrounding properties.

It is understood that information provided in a notification about a pollution incident consists of the following:

Real Pet Food Company - Procedure Manual		
Pollution Incident Response Management Plan		
Page: 9 of 23	Issue: 9	Procedure: 280 App B

- a) The time, date, nature, duration and location of the incident,
- b) The location of the place where pollution is occurring or is likely to occur,
- c) The nature, the estimated quantity or volume and the concentration of any pollutants involved, if known,
- d) The circumstances in which the incident occurred (including the cause of the incident, if known),
- e) The action taken or proposed to be taken to deal with the incident and any resulting pollution or threatened pollution, if known,
- f) Other information prescribed by the regulations.
 - The information required by this section is the information known to the person notifying the incident when the notification is required to be given.
 - If the information required to be included in a notice of a pollution incident by subsection c), d) or e) is not known to that person when the initial notification is made but becomes known afterwards, that information must be notified immediately after it becomes known

d. Actions following a pollution incident

If a pollution incident occurs, there will be a detailed incident investigation and a report will be sent to RPFCo head office and relevant ARA's. If RPFCo were notified of the pollution incident by the public then the complaint will be logged as per the complaint process with subsequent incident reporting also completed.

Following a pollution incident, the PIRMP will continue to be reviewed and tested. RPFCo will continue to liaise with the relevant ARA's to reduce the likelihood of the pollution incident occurring.

All staff and contractors will receive the necessary refresher training, and the key outcomes of the incident investigation will be reported to staff and contractors.

Follow up communications with the community stakeholders will be carried out as directed by the Operations Manager. Further undertakings include but are not limited to the following:

- Face to face contact or telephone call
- Letterbox drops
- Publication of updates on RPFCo website
- Emailing of updates
- Door-knocking

Pollution Incident Response Procedure Overview

1. Immediate Response

- Ensure the safety of people
- Identify the materials involved
- Contain the incident



2. Notify RPFC (Ingleburn) Senior Management



3. Assess the Level of Risk

- Has the incident resulted in harm to the environment?
- Is the incident likely to result in harm to the environment?
- Is the incident affecting or likely to affect people or property or nearby premises?



4. Notify Relevant Authority (if Necessary)



5. Notify Nearby Premises (if Necessary)



6. Clean Up



7. Reporting, Recording, Investigation and Corrective Action

Real Pet Food Company - Procedure Manual		
Pollution Incident Response Management Plan		
Page: 11 of 23	Issue: 9	Procedure: 280 App B

6. Description and likelihood of hazards and pre-emptive actions

6.1 This section has been prepared to meet requirements of clause 98 C (1) (a), (b) and (c) of the POEO (G) Regulation. A pollution incident risk assessment for RPFCo has been prepared to:

- Describe the hazards to human health and the environment;
- Describe the likelihood of any such hazards occurring;
- Outline existing controls to prevent pollution incident occurring; and
- Outline the key pollution response measures

6.2 The pollution risk assessment outlines potential pollution incidents at RPFCo. For each potential pollution risk, there are several controls outlined. Some general controls which are in place to reduce the likelihood of a pollution incident occurring include:

- Site environmental and safety management plans
- Regular inspections and maintenance
- Environmental monitoring
- Correct storage and waste management
- Training and awareness

The site will make all attempts to ensure pollution incident do not occur

The site makes all attempts to prevent pollution incidents; but in the situation where a pollution incidents imminent and may potentially cause detrimental impacts to human health or the environment, the site will contact the necessary stakeholders (employees, contractors, neighbours, ARA's) to provide as much early warning as possible

Risk Category	Potential Hazard / Risk (Impact)	Likelihood	Consequence	Rating	Condition or Event that could or would increase likelihood	Existing Controls / Management Response	Pollution Response Measures
Water System (storm water and sewer)	Contamination of water system causing impact to human health	Unlikely	Minor	Low	1. Poor maintenance and/or control of trade waste system 2. Not covering and/or protecting storm water drainage 3. Uncontrolled discharge of chemicals	1. GMP / Cleaning and sanitation standards 2. Routine maintenance / repair of machinery and plant undertaken within controlled environments 3. Emergency spill kits located throughout the areas of storage 4. Emergency procedures in place to control spills 5. Incident reporting procedures	1. Assess the situation 2. Contact ARA's in accordance with the PIRMP 3. If safe and possible to do so, undertake immediate measures that prevent further damage, such as deployment of spill containment equipment and intercepting substance from entering water system
	Contamination of water system causing impact to the environment	Unlikely	Minor	Low		6. Routine monitoring of water 7. Training and awareness on use of spill kits	4. Seek immediate assistance from a specialist environmental consultant 5. Take direction for ARA's as required 6. Complete incident investigation and send report to relevant ARA's

Risk Category	Potential Hazard / Risk (Impact)	Likelihood	Consequence	Rating	Condition or Event that could or would increase likelihood	Existing Controls / Management Response	Pollution Response Measures
Overall Air Quality	Reduction of air quality causing impact to human health	Unlikely	Minor	Low	1. Poor treatment of trade waste system 2. Poor hygiene of waste disposal area 4. Poor cleaning practices within facility 5. Damage to chemical storage bins/tanks 6. Release of ammonia from refrigeration plant	1. Emergency evacuation procedures 2. Emergency response procedures 3. Fire, smoke & ammonia detection systems	1. Visually Assess the situation 2. Activate emergency evacuation procedures. 3. Contact ARA's in accordance with the PIRMP
	Reduction of air quality causing impact to the environment	Unlikely	Minor	Low		4. Emergency control equipment onsite 5. Incident reporting procedures	4. Take direction for ARA's as required 5. Complete incident investigation and send report to relevant ARA's

Real Pet Food Company - Procedure Manual

Pollution Incident Response Management Plan

Page: 14 of 23

Issue: 9

Procedure: 280 App B

Risk Category	Potential Hazard / Risk (Impact)	Likelihood	Consequence	Rating	Condition or Event that could or would increase likelihood	Existing Controls / Management Response	Pollution Response Measures
Waste	Incorrect handling, use, storage and/or disposal of waste causing impact to human health	Unlikely	Minor	Low	1. Poor control of waste treatment area 2. Poor hygiene of waste disposal area 3. Large production 'event' causing excess rejected product and liquid waste	1. GMP / Cleaning and sanitation standards 2. No access to the site by public 3. Contracts with licenced contractors 4. Waste tracking and reporting streams 5. Incident reporting procedures 6. Training and awareness	1. Visually assess the situation 2. Activate emergency evacuation procedures 3. Contact ARA's in accordance with the PIRMP 4. Seek immediate assistance from a specialist environmental consultant 5. Take direction for ARA's as required 6. Complete incident investigation and send report to relevant ARA's
	Incorrect handling, use, storage and/or disposal of waste causing impact to the environment	Unlikely	Minor	Low			

Risk Category	Potential Hazard / Risk (Impact)	Likelihood	Consequence	Rating	Condition or Event that could or would increase likelihood	Existing Controls / Management Response	Pollution Response Measures
Noise	Noise emissions from site causing impact to human health	Unlikely	Minor	Low	1. Failure of pressure release valves include air compressors 2. Doors left open 3. Grinding work conducted outside facility 4. Alarm testing completed during evening hours	1. All work conducted within building 2. Complaint handling procedure	1. Upon receipt of a noise complaint handle and manage complaint in accordance with the complaints procedure
	Noise emissions from site causing impact to the environment	Unlikely	Minor	Low		3. N/A for environment	2. Immediately investigate noise levels recorded by noise monitoring equipment to determine the source of the noise at the time of incident 3. N/A for environment

6.3 Risk Matrix on conditions or events that could, or would, increase the likelihood

1. Determine the risk score						
SEVERITY						
Probability		INSIGNIFICANT	MINOR	MODERATE	MAJOR	SEVERE
	RARE	Low 1	Low 3	Medium 6	Medium 10	Medium 15
	UNLIKELY	Low 2	Low 5	Medium 9	Medium 14	High 19
	POSSIBLE	Low 4	Medium 8	High 11	High 18	Very High 22
	LIKELY	Medium 7	Medium 12	High 17	High 21	Very High 24
	ALMOST CERTAIN	Medium 11	High 16	High 20	Very High 23	Very High 25

2. Probability...What is the possibility that the effect will occur?		
	Criteria	Description
Almost Certain	Expected to occur in most circumstances	Effect is a common result
Likely	Will probably occur in most circumstances.	Effect is known to have occurred at this site or it has happened
Possible	Could occur at some time	Effect could occur at the site or I've heard of it happening
Unlikely	Not likely to occur in normal circumstances	Effect is not likely to occur at the site or I have not heard of it happening
Rare	May occur only in exceptional circumstances	Effect is practically impossible.

3. Severity...What will be the expected effect?	
Consequence / Impact level	Description
Insignificant	No effect – or so minor that no first aid is required
Minor	First aid treatment required
Moderate	Medical treatment required
Major	Hospital Admission
Severe	Death or permanent disability

4. Record...Risk score on worksheet

Note – Risk scores have no absolute value and should only be used for comparison and discussion.

Score	Action
Very High	Operations must stop immediately until risk / impact is minimised.
High	Agreed controls must be in place and verified to effectively minimise the risk/impact before commencing task.
Medium	Actions to minimise the risk/impact must be completed within 1 month.
Low	Actions, where applicable, must be completed within 3 months

7. Pollutant Inventory

A site inspection has been conducted to establish a potential pollutants inventory and hazards. The inventories include details of at the storages, the maximum quantity that is likely to be stored or held at the facility, and whether the storages have the potential to be associated with a material pollution incident.

Product Name	Location	Maximum Quantity
LPG Tank	External north-side near warehouse office	4.2 Kilo litres
Bulk Flour silo	External north-side near Receiving	80 Tonnes
Fire Well	External south-side near workshop	545,000 Litres
Cooling water tanks	External south-side near trade waste plant	55,000 Litres
Caustic acid tank	Internal south-side in trade waste plant	10,000 kg
Chemical Storage	External south-side near trade waste plant	5,000 kg
Coagulant tank	Internal south-side in trade waste plant	10,000 Litres
Waste holding tank	Internal south-side trade waste plant	70,000 Litres
Ammonia System	Internal/External south-side in trade waste plant	3 Tanks holding ~3T
Bulk Slurry system	Internal south-side (adjacent to carpark)	6 tanks holding 20T each
CIP Tank	External south-side (adjacent to carpark & slurry)	3 tanks holding 2000L each

Real Pet Food Company - Procedure Manual		
Pollution Incident Response Management Plan		
Page: 19 of 23	Issue: 9	Procedure: 280 App B

8. Inventory of Safety Equipment

All emergency response equipment is in easy identifiable locations throughout the facility. Refer to Emergency Evacuation Plan.

RPFC (Ingleburn) staff are trained to know emergency response equipment locations and suitability for use on various types of fires or in the various situations. The emergency evacuation plan shows the egress from the building during an emergency evacuation.

Note: Emergency response equipment includes fire extinguishers, fire hose reels, first aid kits and spill clean-up kits.

Fire Extinguishers

Refer to the emergency evacuation map for the location of fire extinguishers.

This equipment is only suitable to use on fires in their incipient stages, and not fires that are well developed or have been burning for some time.

The classes of fire are:

Class A - Ordinary Combustibles

Class B - Flammable and combustible liquids

Class C - Flammable gases

Class D - Combustible metals

Class E - Electrically energized equipment

Class F - Cooking oils and fats.

Dry Chemical Powder – Red with a white band

These extinguishers are rated ABE and are considered suitable for Class A, Class B, Class C and Class E fires. They are not considered effective for Class F fires.

Carbon Dioxide (CO₂) – Red with a black band

Suitable for Class E fires. Has a limited effectiveness on Class A, Class B, and Class F fires.

Fire Hose Reels

Fire hose reels provide a reasonably accessible and controlled supply of water to combat a potential Class A fire risk.

Spill Kits

There are spill kits located in factory areas as per the site map and these are to be used if a chemical is accidentally spilled onto the floor.

First Aid Kits

First aid kits are located throughout the facility as well the administration office. There is a stocked first aid room, well stocked with first aid supplies.

Safety Data Sheets (SDS)

There are SDS folders kept in the Laboratory. These folders hold a copy of SDS's of each chemical used in the factory.

Emergency Alarms

RPFC (Ingleburn) has emergency alarm fitted, which is hard wired. The fire alarm is monitored and tested by Force Fire (1300 667 704).

Real Pet Food Company - Procedure Manual		
Pollution Incident Response Management Plan		
Page: 20 of 23	Issue: 9	Procedure: 280 App B

9. Minimising harm to persons on the premises

All staff and contractors are to be inducted before completing any work on site. The induction covers procedures for minimising the chance of a pollution incident occurring, managing a pollution incident and actions following a pollution incident

Minimising the impact to persons at RPFCo during a pollution incident must be the highest priority

In the event that a pollution incident requires the evacuation of the site, actions will be completed in accordance with the site evacuation procedure. All staff are informed on the location of evacuation locations through the site inductions, signage and ongoing training. As part of the preparation of the PIRMP, the key aspects of the plan will be provided to staff and contractors

Real Pet Food Company - Procedure Manual		
Pollution Incident Response Management Plan		
Page: 21 of 23	Issue: 9	Procedure: 280 App B

10. Contact details

10.1 Details for those responsible for activating the plan, managing the response and authorised to notify relevant authorities under section 148 of the Act, with site Factory Manager taking the lead

RPFCO Business Contacts	
Person	Phone Number
David Grant – Chief Executive Officer	0419 588 551
Joseph Dalo – Operation Director	0415 380 114
Damien Zahra – Operations Manager - Ingleburn	0478 317 597
Stephen Elliston – Engineering & Reliability Manager	0422 717 174
Gowtham Subramanian – HSE Business Partner	0481 476 162
Ana Sritharan – Quality Manager	0439 936 586
Ryan Monaghan - Food Safety (Form 107 – Food Industry Recall Protocol)	0459 168 997
Mark Torrens – Procurement (Form 137 – Approved Supplier Register)	0476 823 256
Insurance – GSA Policy: 01CL551455	+61 2 8274 8100

10.2 Details for the appropriate relevant authorities

This section has been prepared to meet the requirements of clause 98C (1) h of the POEO(g) Regulation. The following tables outlines the contact details for the appropriate regulatory authorities (ARA's) for reporting incidents

Emergency Services	
Organisation	Phone Number
Fire	000
Ambulance	000
Police	000
Fire and Rescue NSW	1300 729 579
Hospital - Campbelltown General	(02) 4625 9222
Hospital - Campbelltown Private	(02) 4621 9111
Poisons Information Centre	132 126

General Services	
Organisation	Phone Number
Sydney Water	132090
Campbelltown Council	(02) 4645 4000
Liverpool Council	(02) 9821 9222
Environmental - DEC - Chris Kelly	(02) 42244100
Environmental – EPA (24 hours)	131 555
NSW Ministry of Health (south west public health unit)	9828 3130
SafeWork NSW - Narelle O'Brien	131 050
Department of Planning and Infrastructure	9228 6111
Department of Primary Industry	6391 3100

Adjoining Property Owners	
Organisation	Phone Number
Steel Force	1300 883 701
Business Manager: Glenn Needham -	0448 019 561
Representative: Tony Taylor	0488 100 984
Visy PET Containers	8796 6100
Jamie Fenton - Safety Manager	0477 666 851
Tom Lee - Operations Manager	0409 477 503
Univar	9827 6500
Plant Manager: Evangelos Karperos	0418 613 889
SHEQ Manager: Lewis Mancini	0439 446 100

10.3 In the event of a pollution incident – which may impact neighbouring premises or the broader local community, the following methods will include but not limited to:

- Face to face contact
- Telephone to advise community stakeholders of the incident with recommended actions to prevent or minimize harm such as close doors and windows, evacuate building or premises, not to drink or swim in water courses, etc
- Potentially affected community members will be determined based on the nature / scale of the pollution incident and the current weather conditions

10.4 Follow up communications with the community stakeholders will be carried out as directed by the Factory Manager. Further undertakings include but are not limited to the following:

- Face to face contact or telephone call
- Letterbox drops
- Publication of updates on RPFCo website
- Emailing of updates
- Door-knocking

11. PLAN TESTING, TRAINING, REVIEW and RECORDS

11.1 Testing of Plan

This plan will be tested at least once every 12 months as per Procedure 171 – Internal Audits to ensure that the information contained within the plan is accurate and up to date, and that the plan is capable of being implemented in a workable and effective manner. The primary method for testing the plan will be via desktop simulations. Documentation of the name of the person who carried out the test will be recorded on Form 23 – Internal audit matrix

11.2 Staff Awareness/Training

All site personnel will be made aware of the requirements of this plan during the RPFC (Ingleburn) site induction process. Completion of this induction package is a pre-requisite for working at RPFC (Ingleburn). Refresher training will be reviewed annually in conjunction with site mock evacuations

To satisfy the requirements under this PIRMP the training nature and objectives will include:

- Awareness of the PIRMP
- Where this Plan can be accessed
- Pollution incident classification and reporting under this plan
- Spill response actions under this plan
- Other incident response actions under this plan
- Early warnings internally and to neighbours where appropriate
- Specific procedures in dealing with potential pollution incidents e.g. spill response procedure

11.3 Review

The RPFC (Ingleburn) Pollution Incident Response Management Plan (PIRMP) and associated documents, shall be reviewed on an annual basis as part of RPFC (Ingleburn) Food Safety and Quality Management System Review process and according to Procedure 171 – Internal audit

This PIRMP was last tested on	Test by	Result
1 November 2022	Gowtham Subramanmian	Satisfactory

11.4 Records

A Record of events, including details of contacts made, communications, notifications and reports issued will be retained as part of RPFC (Ingleburn) Communication & Information Retention recording procedure.

11.5 Availability of Pollution Incident Response Management Plan (PIRMP)

A copy of RPFC (Ingleburn) Pollution Incident Response Management Plan (PIRMP) is available on the company's website, HAZMAT control box at site entry or through contacting the business contact list.