

DATA SHEET

VXLF 2.250

ROTARY VANE VACUUM PUMPS

oil-free

air-cooled

MAKE IT BECKER.



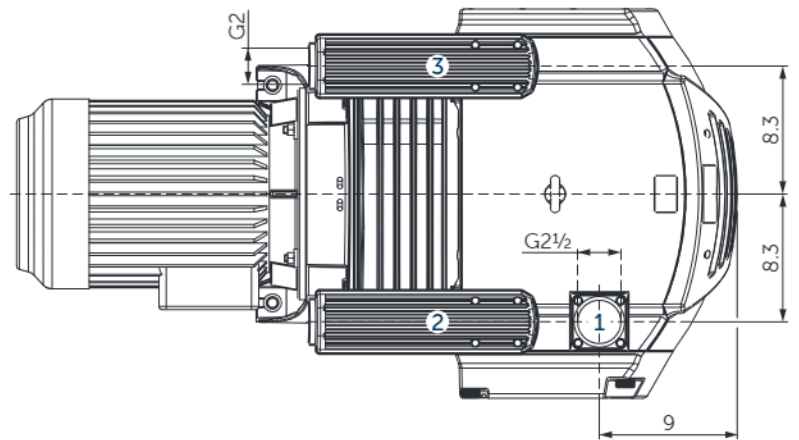
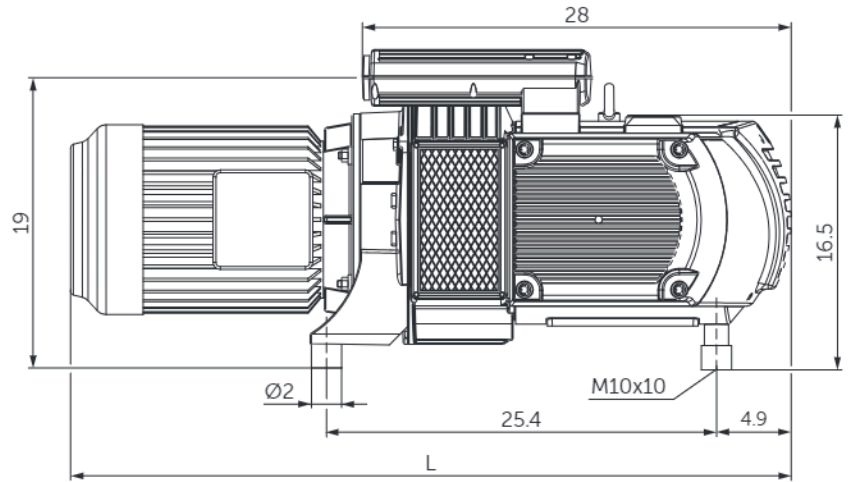
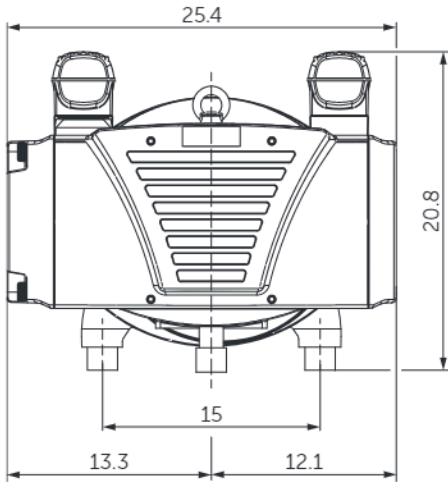

- 1 Vacuum connection (G2½)
- 2 Vacuum relief valve with silencer
- 3 Blow-off valve with silencer
- Including integrated suction air filter
- The motor illustration may vary.
- Dimensions in inch

Suction air rate		Vacuum		Emission sound pressure level ¹⁾		Weight without motor
50 Hz	60 Hz	50 Hz	60 Hz	50 Hz	60 Hz	lbs
144	169	23.6	23.6	77	79	333

¹⁾ According to DIN EN ISO 3744 (KpA = 3 dB(A)), 39.4 inch distance, at medium load, both connection sides piped

3~ Motors												L	
#	50 Hz				60 Hz				Version	Weight lbs	inch		
	hp	V	rpm	A	hp	V	rpm	A					
01	7.4	Δ230/Y400	IE3	972	23.4/13.5	8.9	Δ265/Y460	IE3	1170	23.4/13.5	IP55 • ISO F • bimetal	224.9	45.1
							Δ230/Y400			1162			
02	7.4	Δ400/Y690	IE3	976	13.5/7.8	8.9	Δ460/Y795	IE3	1173	13.6/7.9	IP55 • ISO F • bimetal	235.9	45.1
							Δ400/Y690			1160			
03						8.9	YY230/Y460	IE3	1175	27.8/13.9	UL(E235514) • CSA CC329B IP55 • ISO F • bimetal	235.9	45.1
							YY208			1159			
04	7.4	Δ200/Y350	IE3	974	26.9/15.5	8.9	Δ220/Y380-400	IE3	1168	26.7/15.4-15.3	IP55 • ISO F • bimetal	235.9	45.1
							Δ200/Y350			1162			
05						8.9	Δ400/Y690	IE3	1175	15.2/8.8	UL(E235514) • CSA CC329B IP55 • ISO F • bimetal	235.9	45.1
06						10.0	208-230/460		1175	28.5-25.8/12.9	NEMA • IP55 • ISO	289.0	49.1

• Current consumption and rotation speed may vary. Tolerance in each case -1.5/+2%

SERIES X: BECKER INNOVATION WITH TOP WARRANTY

Equipped with specially developed vanes, these oil-free rotary vane pumps distinguish themselves by high abrasion resistance, and with that extremely long service lives. Due to the low wear there is also minimal dust, so the series X pumps are perfectly suited for precision processes under clean room conditions.

This innovation branded by Becker is outstanding not only because of its 100 percent oil-free operation, excellent degree of efficiency and low power consumption.

In the area of sensitive vacuum, series X also guarantees precise low-pulsation air conduction.

Becker guarantees for these pumps a vane life-time of 20,000 operating hours or a maximum of 3 years. The enhanced longevity of X series pumps also extends service life intervals, and can cut out the need for frequent service visits with costly pump failures now no longer an issue.



ADVANTAGES

- Quick, clean and quiet
- Oil-free
- Wear resistant
- Energy saving
- Long-life reliability

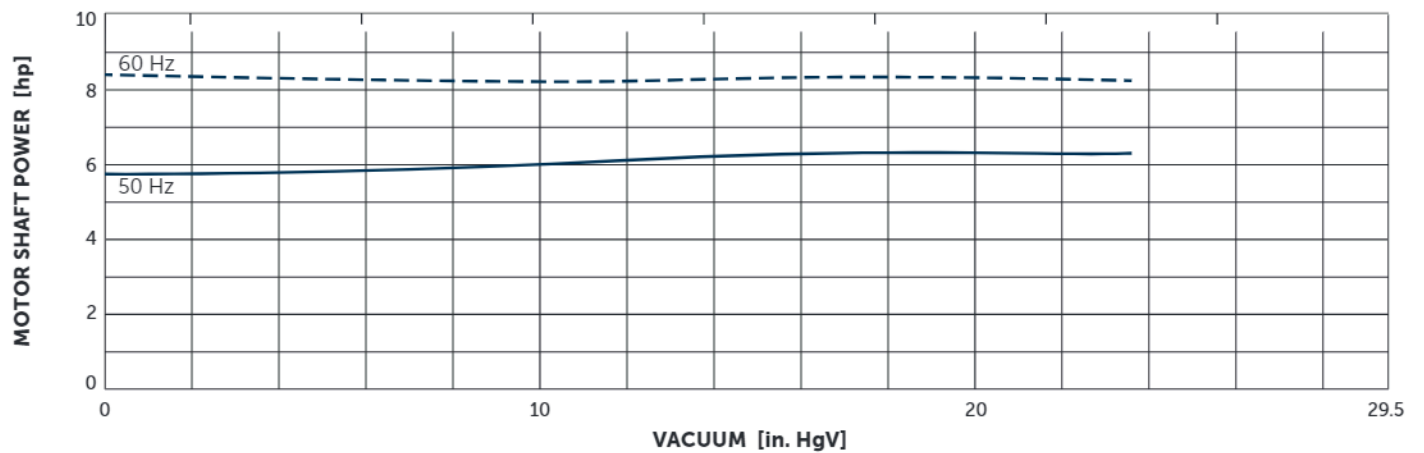
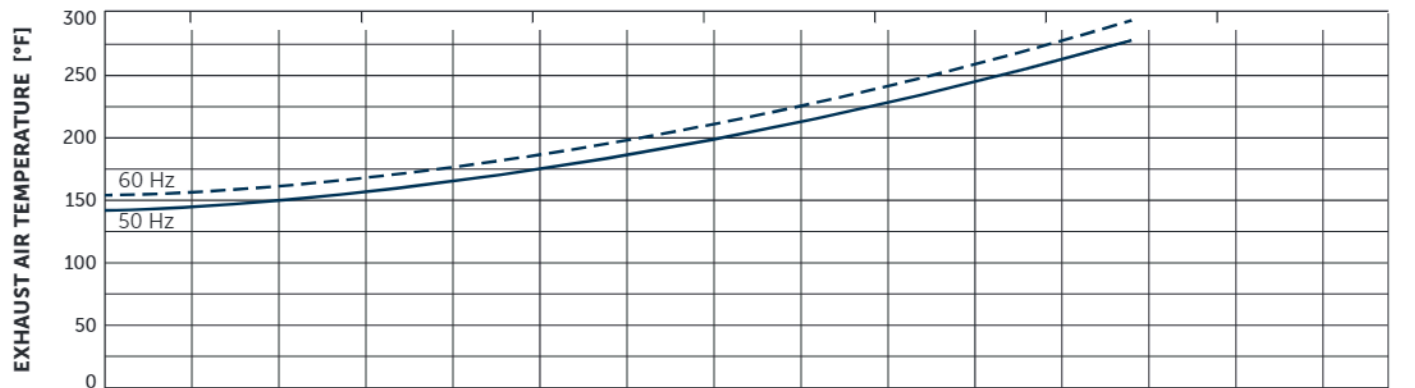
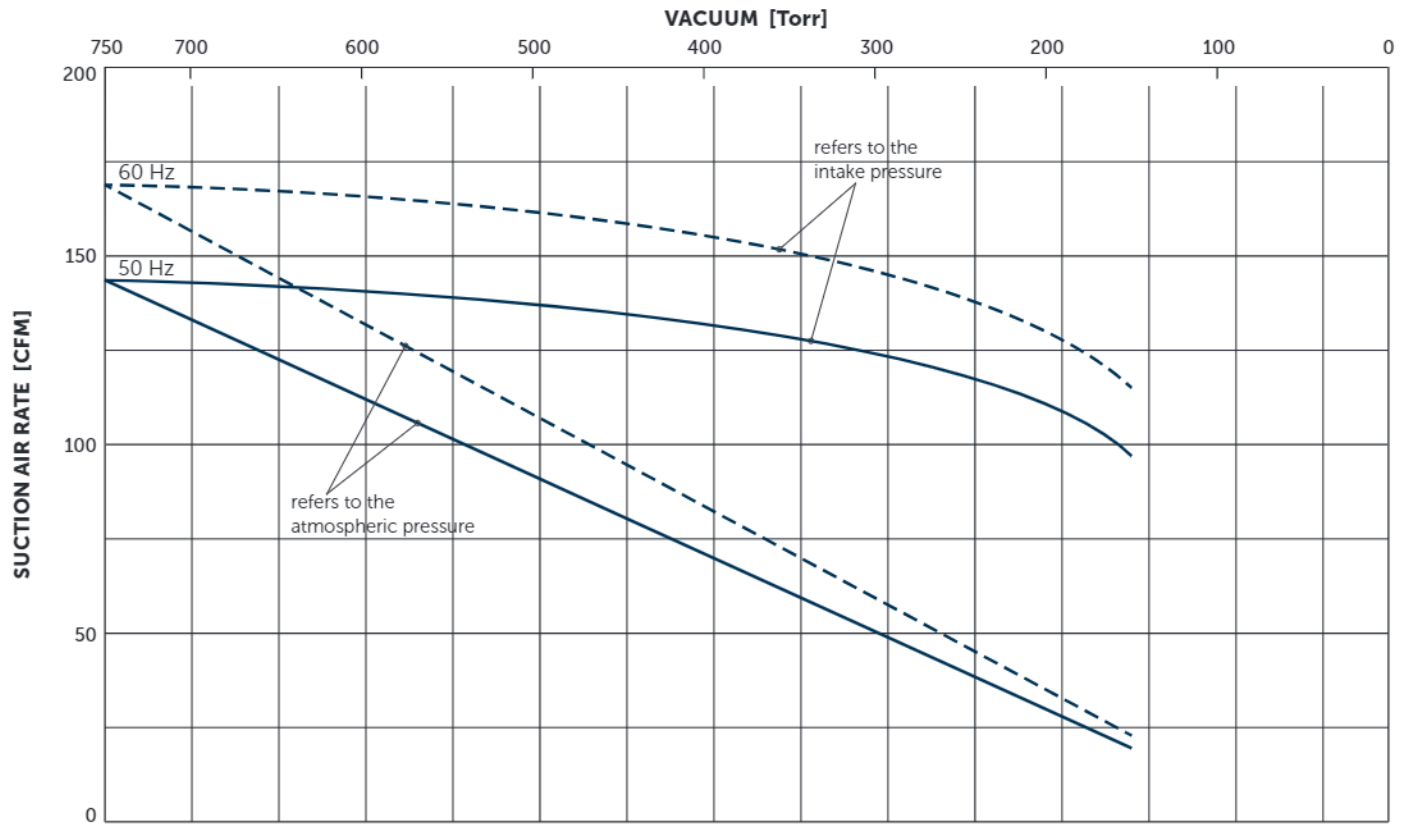

Reference data (atmosphere): 0 in. HgV, 68°F; Tolerance: ±5%

+ VARIANTS AND ACCESSORIES

- **VARIAIR VXLF 2.250/0-400** with frequency inverter¹⁾
- Integrated non return valve
- External suction filter¹⁾
- Sound proof box SH 12¹⁾



VARI AIR VXLF 2.250/0-400



Example for an external suction filter



Sound proof box SH 10

¹⁾ See separate data sheet
• Possible combinations on request

MAKE IT BECKER.

