

Misure / Measures

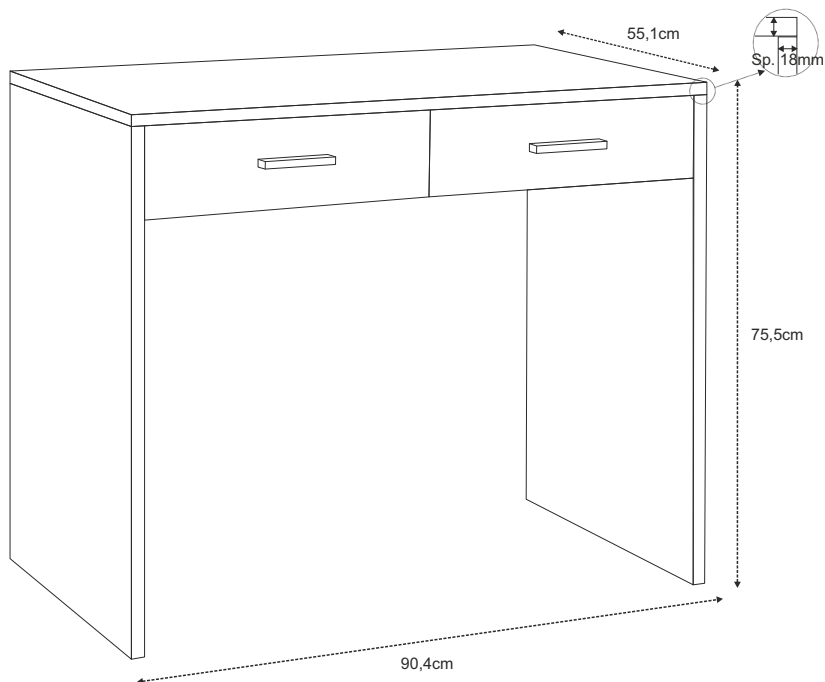

Dettagli / Details







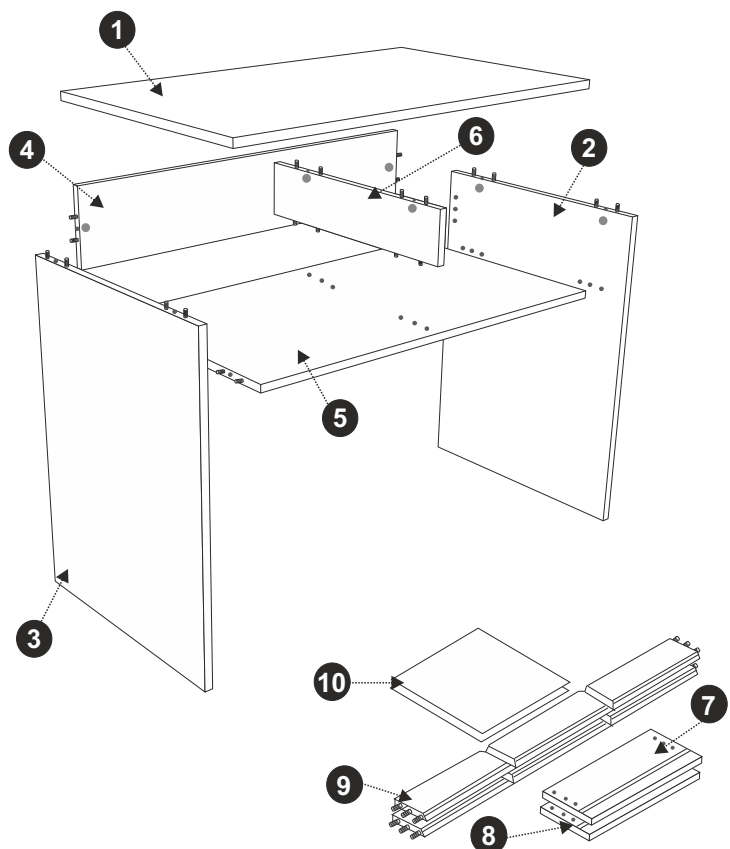

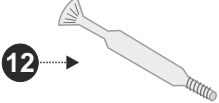

- Struttura materiale in truciolare nobilitato
- Guide cassetto a rullo
- Maniglie verniciate cromo satinato
- Mobile in kit
- Material structure in engineered wood
- Roller slides drawer
- Chrome-plated handles
- Kit furniture

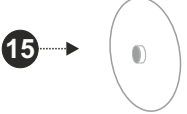
Utile cassetto  
Usefull drawer  
h.8 l.37 p.28cm

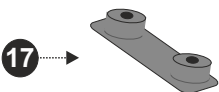
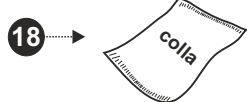
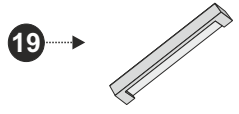
Componenti / Elements

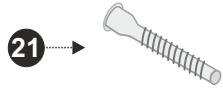

Pos.	Pezzi / Pcs	Descrizione / Description
1	1	Coperchio (904 x 551 x 18mm) Cover (904 x 551 x 18mm)
2	1	Fianco dx (735 x 550 x 18mm) Rh Side (735 x 550 x 18mm)
3	1	Fianco sx (735 x 550 x 18mm) Lh Side (735 x 550 x 18mm)
4	1	Tramezza (867 x 174 x 16mm) Partition Shelf (867 x 174 x 16mm)
5	1	Tramezza orizzontale (867 x 493 x 16mm) Hor. Partition Shelf (867 x 493 x 16mm)
6	1	Tramezza verticale (111 x 493 x 16mm) Ver. Partition Shelf (111 x 493 x 16mm)
7	1	Davanti Cassetto Dx (430 x 123 x 16mm) Rh Front Drawer (430 x 123 x 16mm)
8	1	Davanti Cassetto Sx (430 x 123 x 16mm) Lh Front Drawer (430 x 123 x 16mm)
9	2	Sponda Cassetto (399 x 300 x 85mm) Drawer Structure (399 x 300 x 85mm)
10	2	Fondo Cassetto (386 x 301 x 3mm) Drawer Backrest (386 x 301 x 3mm)

Accessori / Equipment	Pos.	Pezzi / Pcs	Descrizione / Description
	11	2	Guide cassetto a rullo Roller slides drawer
	12	12	Perno per eccentrico Cam Bolt
	13	8	Eccentrico x sp. 16mm Cam th. 16mm
	14	4	Eccentrico x sp. 18mm Cam th. 18mm
	15	12	Tappino copri eccentrico Cam covercap
	16	2	Tappino copri vite Screw covercap
	17	4	Piedini Feet
	18	2	Colla Glue
	19	2	Maniglia Handle
	20	4	Vite 4x20 Screw 4x20
	21	2	Vite 7x50 Screw 7x50
	22	12	Vite 3,5x20 Screw 3,5x20
	23	4	Vite Euro 6,3x9 Euro Screw 6,3x9
	24	4	Vite Euro 6,3x13 Euro Screw 6,3x13

### Istruzioni di montaggio / Assembly Instructions

**A**

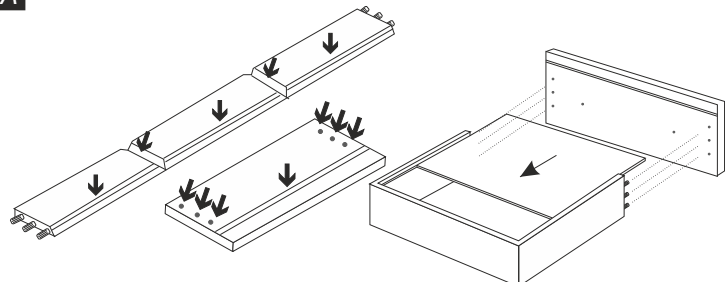

Distendere su un piano i davanti cassetto (7 e 8) e le sponde cassetto (9), ed applicare la colla (18). Chiudere le sponde sui fondi cassetto (10) ed inserire i fianchi delle sponde nei davanti.

Lay out the front drawer (7 and 8) and the shores (9), and apply the glue (18). Close the structure drawer on the drawer backrest (10). Insert the shore side on the front.

**B**

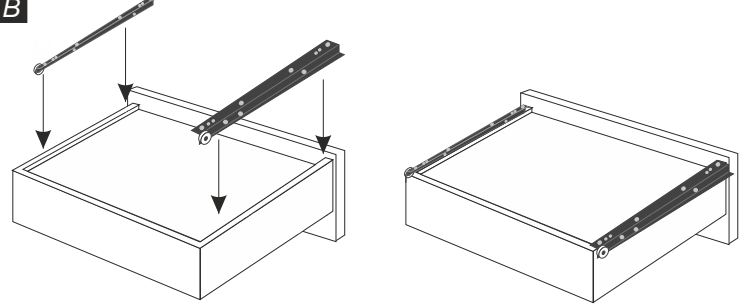

Capovolgere il cassetto e fissare le guide cassetto (11) sui bordi dx e sx sul fondo del cassetto con le viti 3,5x20 (22). Le guide vanno poste con le ruote rivolte verso l'esterno e retro del cassetto.

Flip the drawer and fasten the drawer runners (11) on the right and left edges on the bottom of the drawer with the screws 3,5x20 (22). The runners must be placed with the wheels pointing outwards and back of the drawer.

**C**

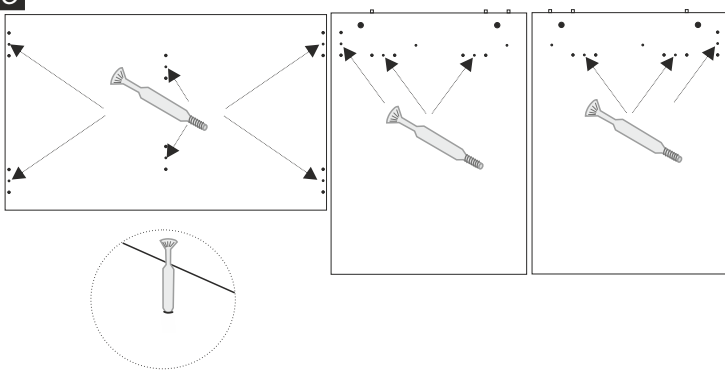

Avvitare i perni per eccentrico (12) nei fori sul coperchio (1) e sui fianchi (2 e 3). Avvitarli sino a fine corsa.

Screw the cam bolts (12) into the holes on the cover (1) and sides (2 and 3). Screw them up at the end of the stroke.

**D**

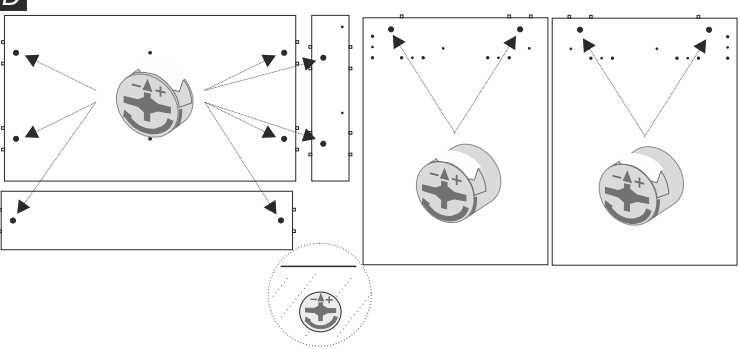

Inserire gli eccentrici sp. 18 (14) nei fori posti sui fianchi (2 e 3). Gli eccentrici sp. 16 (13) sulle tramezze (4, 5 e 6). Gli eccentrici vanno inseriti con la freccia rivolta verso il bordo più vicino come mostrato in figura.

Insert the cams th. 18 (14) into the holes on the sides (2 and 3). The cams th. 16 (13) on the partitions (4, 5 and 6). The eccentrics must be inserted with the arrow pointing toward the nearest edge as shown in the figure.

Istruzioni di montaggio / Assembly Instructions

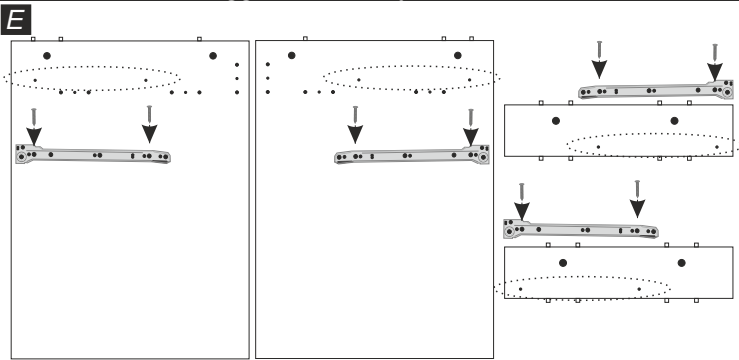

Fissare sui fianchi (2 e 3) le guide cassetto (11) con le viti 6,3x13 (24). Fissare su entrambi i lati della tramezza (6) le guide cassetto (11) con le viti 6,3x9 (25).

*Fix on sides (2 and 3) the drawer runners (11) with the screw 6,3x13 (24). Fix on both sides of the partition (6) the drawer runners (11) with the screw 6,3x9 (25).*

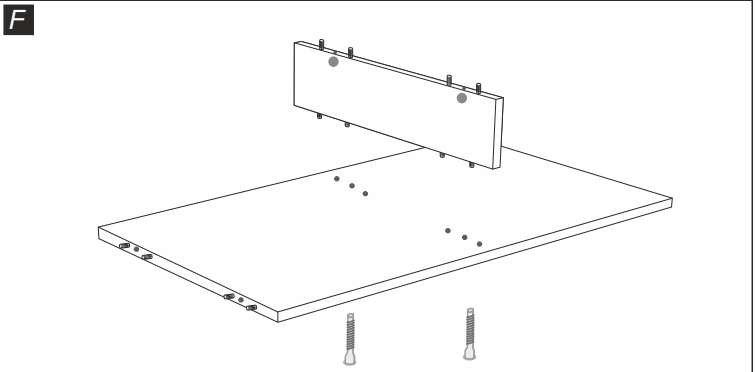

Inserire la tramezza (6) sulla tramezza (5). Sull'altro lato della tramezza (5) fissare le due tramezze con le viti 7x50 (21). Coprire le viti con i tappini coprivite (16).

*Insert the partition (6) on the partition (5). Act on the other side of the partition (5) to fix them with the screws 7x50 (21). Cover the screws with the screw covercaps (16).*

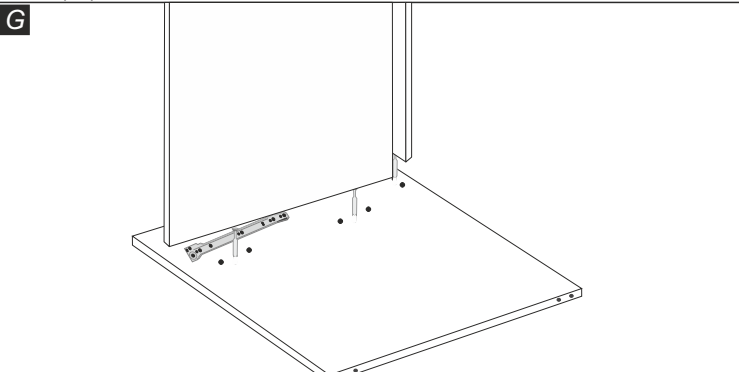

Posizionare il fianco sx (3) su una superficie piana con i fori rivolti verso l'alto. Sistemare la tramezza (5) e la tramezza (4) sul fianco sx (3), infilandolo sui perni per eccentrico inseriti precedentemente.

*Place the Lh side (3) on a flat surface with the holes facing upwards. Place the partition shelf (5) and the partition (4) on the Lh side (3), inserting it on bolts inserted previously.*

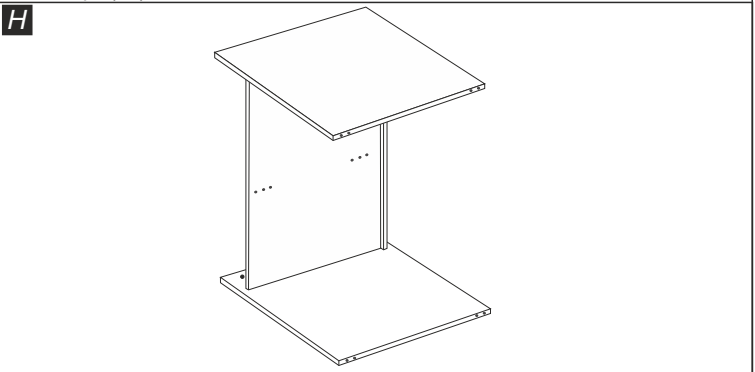

Sistemare ora il fianco dx (2) sulle tramezze (4 e 5), infilandolo con i perni per eccentrico inseriti precedentemente.

*Now place the rh side (2) on the partition shelves (4 and 5), inserting it with the bolts inserted previously.*

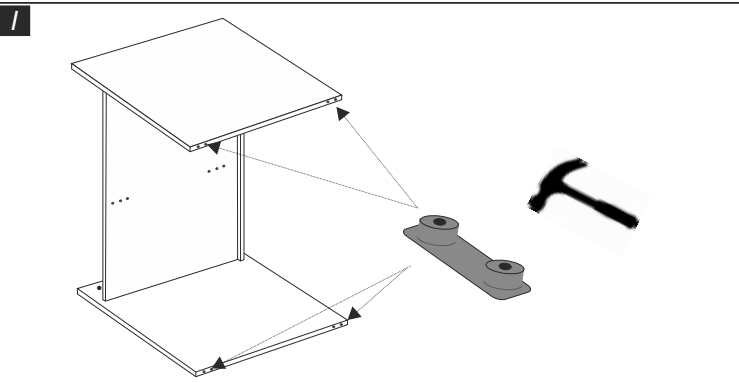

Inserire negli appositi fori posti sui fianchi, i piedini (17).

*Insert in the holes located on the sides, the feet (17).*

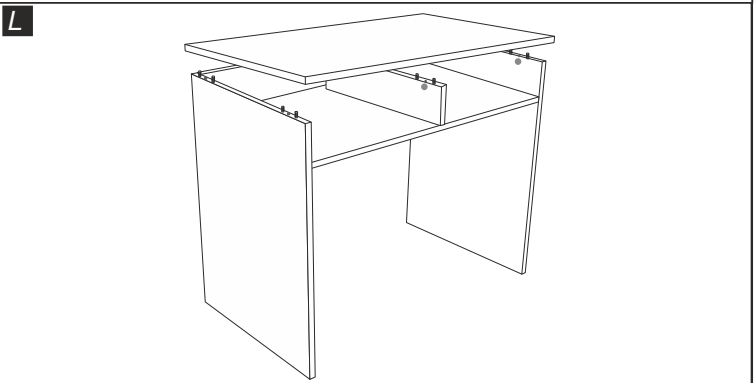

Mettere in piedi ora il telaio così ottenuto, composto dai fianchi dx e sx (2 e 3) e dalle tramezze (4 e 5). Chiudere l'insieme con il coperchio (1), infilandolo sui perni per eccentrico (12) inseriti precedentemente.

*Place now the chassis thus obtained in a vertical position, comprising the rh and lh sides (2 and 3) and the partition shelf (4 and 5). Close all with the cover (1), on the top, inserting it on the bolts (12) inserted previously.*

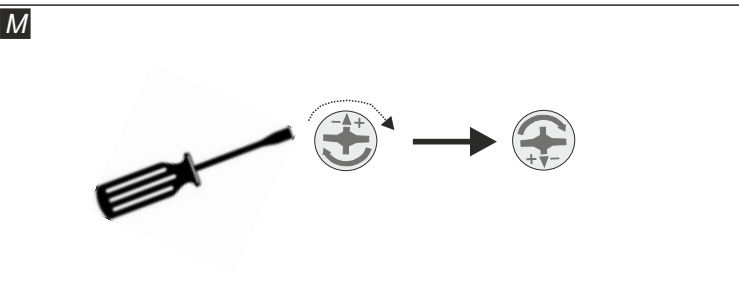

Ruotare gli eccentrici (13 e 14) posizionati sui fianchi (2 e 3) e sulle tramezze (4, 5 e 6) in senso orario in modo da fissare il coperchio ai fianchi e tramezza. Coprire gli eccentrici (13 e 14) con i tappini copriforo (15). Coprire anche le viti (21) sulla tramezza (5) con i tappini coprivite (16).

*Rotate the cams (13 e 14) placed on sides (2 and 3) and partitions (4, 5 and 6) clockwise to fix the cover to the partitions and sides. Cover the cams (13 and 14) with the cam covercaps (15). Cover also the screws (21) on the partition (5) with the screw covercaps (16).*

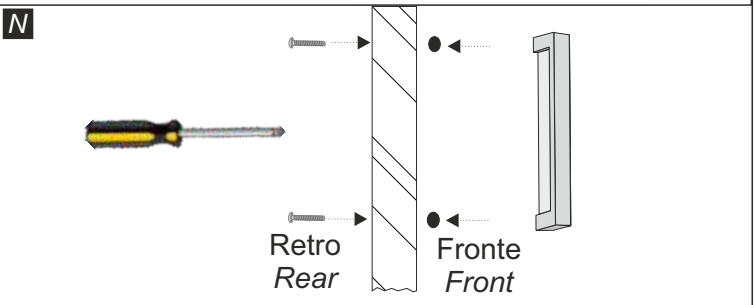

Inserire i cassetti. Fissare ora le maniglie (19) ai cassetti con le viti 4x20 (20).

*Insert the drawers. Fix now the handles (19) to the drawers with the screws 4x20 (20).*

Scheda Prodotto / Product Sheet

PRODOTTO PRODUCT	COMPONENTI COMPONENTS	TIPOLOGIA E MATERIALI PER LA STRUTTURA TYPOLOGY AND MATERIAL FOR THE STRUCTURE	TIPOLOGIA E MATERIALI DI RIVESTIMENTO, SUPERFICI TYPOLOGY AND COATING MATERIAL SURFACES	TIPOLOGIA E MATERIALI PER I BORDI TYPOLOGY AND MATERIAL FOR THE EDGES
Scrivania Desk	Fianchi Sides	Truciolare nobilitato Engineered wood	Carta impregnata con resine melaminiche Paper impregnated with melanine resins	Carta impregnata con resine termoplastiche e termoindurenti o ABS Paper impregnated with thermoplastics and thermosetting resins or ABS
	Top Base			
	Tramezza Partition Shelf			

ALTRE CARATTERISTICHE OTHER CHARACTERISTICS	USO USE	PULIZIA CLEANING	SMALTIMENTO DISPOSAL
<p>Materiale di classe E1: bassa emissione di formaldeide. Questi pannelli possono essere utilizzati senza causare una concentrazione di equilibrio nell'aria della camera di prova (definita nella norma UNI EN 717-1) maggiore di 0,1 ppm, limite raccomandato all'Organizzazione Mondiale della Sanità per gli ambienti di vita e soggiorno.</p> <p><i>Material class E1: low formaldehyde emissions Class E1 panels can be used without causing an equilibrium concentration in the air in the test chamber (defined in the UNI EN 717-1) greater than 0.1 ppm, limit recommended by the World Health Organization for life and living environments.</i></p>	<p>Mobile multiuso Multiuse cabinet</p>	<p>Utilizzare panno inumidito con alcool diluito o con prodotti per la pulizia delle superfici lavabili, purché privi di abrasivi e/o solventi.</p> <p><i>Use cloth moistened with alcohol diluted or with cleaning products for the washable surfaces, if they are free of abrasives and/or solvents</i></p>	<p>Al termine del ciclo di vita, il prodotto può essere conferito alla raccolta differenziata o speciali piattaforme RSU</p> <p><i>At the end of the life cycle the product may be conferred on the differentiated collection or special platforms RSU</i></p>

**ATTENZIONE**

Se al momento dell'apertura della confezione dell'imballo si evidenziassero anomalie delle parti strutturali occorre contattare il fornitore prima del suo utilizzo

**WARNING**

*If at the time of the opening of the packaging, it yields anomalies of structural parts you need to contact the supplier before its use.*



**SARMOG s.r.l.**

Via Pizzamiglia, 7  
42016 S.Girolamo di Guastalla (RE) - Italy

Tel +39 0522 228058  
Fax +39 0522 228442

Web www.sarmog.com  
E-mail info@sarmog.com

**SARMOG**  
L I F E S T Y L E H O M E