

DR. GERD HEUSCHMANN

Author of *Tug of War* and *Collection or Contortion?*



NOW
IN
PAPERBACK

BALANCING ACT

THE HORSE IN SPORT—AN IRRECONCILABLE CONFLICT?



CONTENTS

FOREWORD by Sabine Neumann	ix	IV. TRAINING	
INTRODUCTION by Kurd Albrecht von Ziegner	xi	<i>Part One—More than Riding</i>	30
ABOUT THE BOOK AND THE AUTHOR	xiii	Early Education	31
by Heinrich Bottermann, DVM		Respect and Trust	32
		With One Another, Not Against One Another	33
		Motivation	35
I. HORSE SPORT		V. TRAINING	
<i>A Current State of Affairs</i>	xviii	<i>Part Two—Physiological</i>	36
The Evolution of Riding Sports	1	Structure and Development of the Musculature	37
The Lack of Equestrian Instruction and Its Consequences	4	Systematic Gymnastics	41
Ethics in Horse Sports and the Role of the Judge	6	VI. THE SEAT	
Modern Breeding and Its Consequences for Training	10	<i>Supple and Balanced</i>	42
		Tense Rider—Tense Horse	43
II. RIDING		The Psychological Components	44
<i>Art or Commerce?</i>	12	Forced Longitudinal Flexion and Its Consequences	47
Young Horses—The “Hope” Market	13	The Forward Seat as an Alternative	50
The Young Horse Carousel	14	VII. INFLUENCE	
III. HORSE AND SPORT		<i>Tactful and Effective</i>	52
<i>An Irreconcilable Conflict?</i>	20	Aids for the Lightest Possible Communication	53
What Does “Horsemanship” Mean?	21	Rein Aids and Holding the Reins	55
Where Do I Stand as a Rider?	22		
Correction—Not Pleasant, but Necessary	24		
Riding as a Dialogue between Man and Horse	28		
Recognize Strengths and Respect Limitations	29		



VII. BALANCE

<i>The Most Important Criterion</i>	58
The Training Scale as a Guide	59
Developing Balance	62
Back Activity as a Requirement	63
Back Movers, Hyperflexed Back Movers, and Leg Movers	66
Contact as a Result of a Swinging Back	70
The Importance of Rhythm for Impulsion and Carrying Power	72

IX. SUPPLENESS

<i>From Rhythm to Contact</i>	74
The Quality of Contact	75
Understanding Forward	76
Wait and Find the Rhythm	78
Suppleness	79

X. STRETCHING

<i>Always in Balance</i>	80
Understanding Forward and Downward	81
Incorrect Stretching	83
“Throughness” as a Goal of Training	84

XI. IMPULSION

<i>Loved and Misunderstood</i>	86
Measured Development of Lengthenings	87
“Spectacular” Steps as the Measure of All Things	89
From Pushing Power to Carrying Power and Back	92
Purity of the Paces	92

XII. THE SPORT OF DRESSAGE

<i>Nothing but Show?</i>	96
A Spectacle or Correct Training?	97
Demonstration of Classical Training	98
The Political Background of the Sport	99
The Judgment of Judges	101
The Role of the Public	102

XIII. STRAIGHTNESS

<i>A Special Challenge</i>	104
Natural Crookedness	105
The Causes	106
Horizontal and Vertical Balance	108
First Degree Bend	110
Second Degree Bend	111

XIV. COLLECTION

<i>Shifting Horizontal Balance</i>	112
The Biomechanics of Collection	113
Lengthening and Shortening the Frame	
The Role of the Lumbo-Sacral Joint	115
The Role of the Trunk Musculature	119
Explanation of the Different States of Balance	121
The Biomechanics of Relative Elevation	121
Consequences for Training	125

XV. THE POLL

<i>A Joint with a Key Function</i>	128
Sensitive Contact as a Gift	129
The Correct Position of the Poll	131

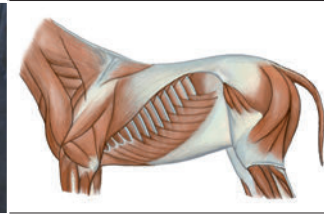
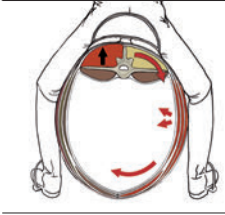
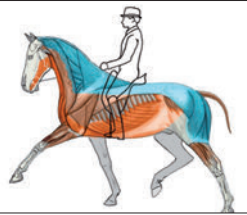

Dealing with the Stiff Poll	133
What Is a Supple Poll?	133
Suppleness of the Poll and an Open Poll Angle	135
Consequences for Training	136

XVI. THE ACTIVE MOUTH

<i>A Prerequisite for Balance</i>	138
The Psychological Components of "Chewing"	139
The Biomechanical Components of "Chewing"	140

XVII. SHIFTING THE BALANCE

<i>Biomechanics</i>	144
Fluid Transitions	145
The Importance of Lateral Movements	147
Consequences for Work	148
Why Does a Horse "Chew"?	150
Jaw-Mobilizing Effect of the Lower Muscle Chain	153

XVIII. REIN LAMENESS

<i>An Unpleasant Diagnosis</i>	156
Incorrectly Dealing with Natural Crookedness	157
Diagnosis	158
Shortened, Second Support Phase	160
Reaction of the Long Back Muscles	160
Shortened, Second Swing Phase	163
The Gait Pattern After a Change of Direction	164

XIX. THE VETERINARIAN

<i>In the Arena of Political Conflict</i>	166
Duty to Take Action for Animal Welfare	167

Accustomed to Forceful Methods?	168
Pleasure Riding as a Problem Area	170

XX. HYPOTHESIS

<i>"Occupational Illness"—Suspensory Injury</i>	172
Sick and Injured Due to Forceful Riding	173
Tense Trunk Musculature and Its Consequences	173

XXI. INITIAL STEPS

<i>Retraining Poorly Ridden Horses</i>	176
Balance Disruption Caused by Training Errors	177

XXII. INITIAL STEPS IN RETRAINING

<i>Part One—The Tense Horse</i>	180
Deficits in Basic Training	181
Correcting Balance in the Forward Seat	184
Initial Walk Phase with Stretching	187
Longeing with a Cavesson	188
The Psychology of a Horse in Retraining	189

XXIII. INITIAL STEPS IN RETRAINING

<i>Part Two—The Leg Mover</i>	190
The Horse with a Low Back Position	191
Rhythmically Forward	192
Activate the Hind Leg	193
Longer Neck and Lateral Movement	194
Cross-Country Work	194

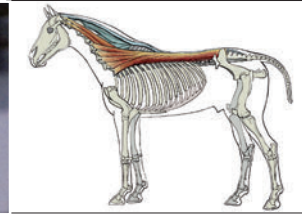
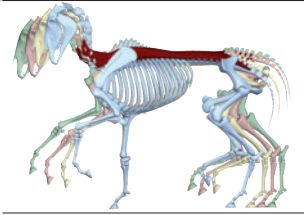

XXIV. INITIAL STEPS IN RETRAINING

<i>Part Three: The Hyperflexed Back Mover</i>	196
The Horse with a "Pushed Up" Back	197
"Rollkur" and Hyperflexion	198
Learned Helplessness	199
Extreme Disruption of Balance and the Flight Reflex	199
Psychological Relaxation	200
Longing with a Cavesson	202
Very Difficult Horses with a Flight Tendency	203
Resistance Against the Rider's Leg	204
The Interplay of the Aids	204

XXV. INITIAL STEPS IN RETRAINING

<i>Part Four: The Horse That Has Fallen Apart</i>	206
The Leg Mover Caused by Insufficient Positive Tension	207
The Training Level of the Pleasure Rider	207
Balance "Disrupted" by the Rider's Lack of Knowledge	209
Minimum Requirements for Pleasure Riders	209
Outside Work in a Regular Forward Rhythm	209

XXVI. FUNDAMENTALS

<i>Thoughts on Retraining</i>	210
Calm Lateral Work at the Walk and Later at the Trot	211
Ideal and Correcting Use of the Reins	214

XXVII. THE VETERINARIAN

<i>Expertise and Pre-Purchase Exams</i>	218
Training as a Criterion of Value	219

XXVIII. SUMMARY

<i>A Review</i>	221
Back to the Proven Principles of Training	222

XXIX. SCIENCE

<i>Its Role and Limitations</i>	224
Methods of Proof are Lacking	225

XXX. RIDING CULTURES

<i>Dialogue Instead of Exclusion</i>	227
Accepting Different Training Goals	228

THANK YOU 230

BASIC RULES OF CONDUCT

IN HORSE SPORT 231

INDEX 233

XV.

THE POLL

A Joint with a Key Function



SENSITIVE CONTACT AS A GIFT



An even and sensitive contact results from a swinging, relaxed back.

A final prerequisite for vertical flexion is a supple, or as riders say, a “yielding” poll. The importance of the rounding of the poll is highlighted in a passage from *Von der Koppel bis zur Kapriole* [From paddock to capriole] (Olms Press, Hildesheim, Zürich, New York, 2001). Waldemar Seunig writes on p. 134:

“Longitudinal flexion and elevation are not essential goals of dressage training but rather results and symptoms of expert work.”

All that is in front of the rider (longitudinal flexion, relative elevation) is a gift from the horse based on correct, good work from a tactful and supple seat. You need to carefully manage and organize the gift with sensitive hands. You can ask the hindquarters for this gift, and it shouldn’t be more than a request, with fine leg and seat aids. Seunig says very correctly, “At the end, it is only about the rider’s seat and the horse’s hind legs.” The sooner the rider grasps this concept, the faster she finds the harmony she longs for.

The development of diagonal aids is important in this context. In order to be able to develop first degree bend (indirect—see p. 110), it is necessary to

© From *Große Tieranatomie* by Gottfried Bammes (Wu Wei Verlag 2010)

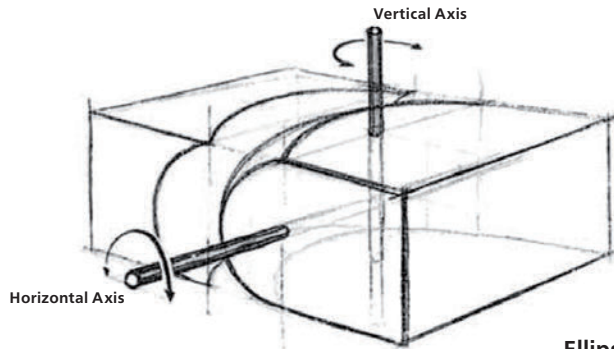

Ellipsoidal Joint

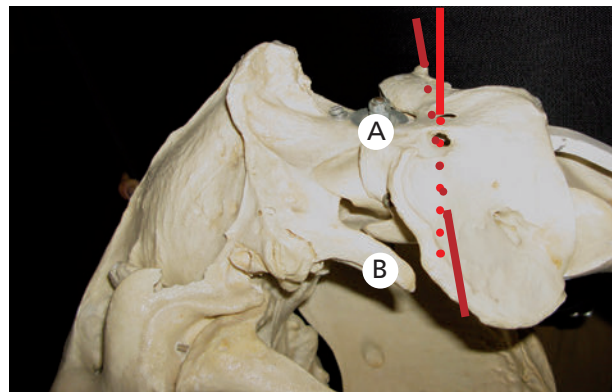
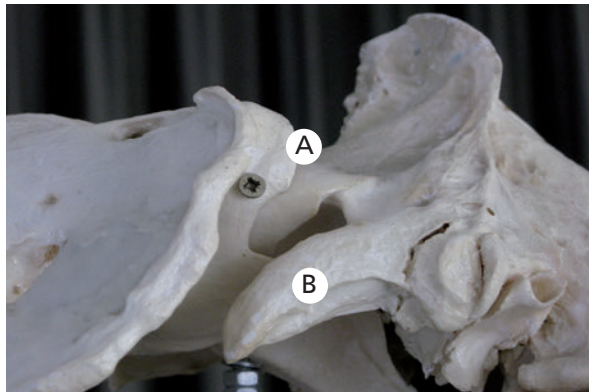
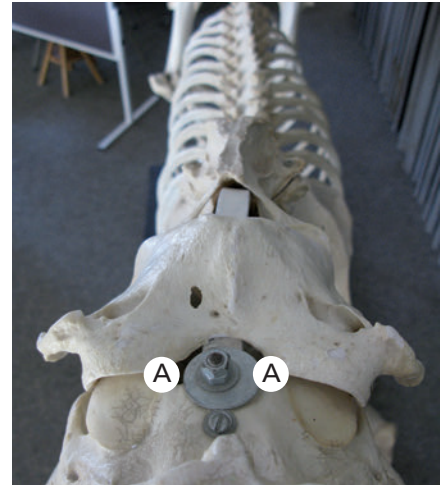

The poll (atlanto-occipital joint) (A) is the joint between the head and the first cervical vertebra. It is a crosswise-oriented, ellipsoidal joint that allows two movements: first, an up-and-down movement of the head; and second, a sidewise flexion (positioning) of the poll. A rotation (head tilt) of this joint is not possible. The *processus paracondylares (jugulares)* (B), which are two bony projections that protrude an index finger's length from the base of the skull, stiffen the poll if the head is positioned too deeply with the nose behind the vertical. Therefore, correct positioning of the poll is only possible with an open poll angle.

already have a good and consistent contact. In retraining a horse that doesn't have a well-established contact, the horse will typically support himself on the outside rein and/or stay "behind the inside rein" when going to the hollow direction. To the stiff direction, contact problems cause the horse to support himself on the inside (positioning) rein. The horse

can't or won't step up to the outside (leading) rein.

Positioning plays a large role in the correction of contact along with vigorous "forward" and "straight" movement. If such a horse allows himself to be correctly positioned, he'll step to the outside rein, which is the start of first degree flexion.

Positioning the poll

Positioning occurs only in the poll. A sidewise flexion of the head (lateral flexion) is only possible in the upper cervical area (atlanto-occipital joint). The joint between the first and second cervical vertebrae prevents lateral positioning movement (lateral flexion). Based on its anatomy, two movements are possible in the poll:

- a) Vertical flexion and extension (this corresponds to the lowering or raising of the head).
- b) Lateral flexion, sidewise bending, depending on the length of the *procc. paracondylares*, (see the bottom left photo on p. 130), the positioning to the left or right, which is positioning in the equestrian sense.

Rotation of the head, as when the horse tilts his head, is only possible one joint farther back, between the first and the second cervical vertebrae.

Correct contact, where the horse goes to the bit with a “chewing” mouth, is only possible with a yielding poll.

To pull the whole neck all the way sideways is fully counterproductive in many ways. The poll becomes stiff and the neck is “torn loose” from the withers. The poll should be supple and the neck stabilized by muscle at the withers. A good sign of correct positioning is when the crest of the neck flips to the side to which the horse is positioned.

THE CORRECT POSITION OF THE POLL

In order to achieve contact that is correct according to the Training Scale, it is extremely important to maintain the poll as the highest point of the neck. That should not be confused with elevation. A young horse going in natural balance generally positions his neck according to the anatomy of his neck and back length so that he carries a relaxed back. For example, a short, powerful horse positions his neck somewhat higher, a long horse with a deeper backline, somewhat lower.

In order to have good contact, the rider must be careful that the horse’s nose is in front of the vertical as well as the poll up. A young horse ridden with a deep, long neck constantly behind the vertical (even slightly so) always falls on the forehand and cannot find his balance. The argument that “A little bit behind the vertical is not a problem,” or “Sometimes you have to get the horse ‘through,’” is technically

false. Every active backward effect with the intention of making the poll angle smaller is damaging and makes it impossible to achieve desirable suppleness of the poll. The horse’s back reacts proportionately according to the type of horse and anatomy—it hollows (leg mover) or tightens (hyperflexed back mover). In no way will the horse arch up according to classical teachings to allow the movement to come swinging through.

It is true that it is not a big problem when a horse, usually one in retraining, now and then goes behind the vertical. But this position should not last long. As soon as the back relaxes, the correct head and neck position is automatic!

And it is especially so when the horse seeks and goes to the hand/the bit. A giving hand of the rider is fundamental to suppleness of the horse’s back. The old saying is true: “The ears should be as far from



A young horse in natural balance. The back is not yet completely relaxed.

the rider as possible, the poll the highest point and the poll muscles should always be supple (soft poll)."

At this point, I would like to remind you of the passage by B. H. von Holleuffer (p. 69) describing

contact as being the result of a softly swinging back. The poll position and contact are the result of good training, not the prerequisite!

DEALING WITH THE STIFF POLL

Classical Riding teachings logically stem from anatomy and biomechanics. Why is it so difficult to put them into practice? Perhaps because there is always the same problem: Many riders have little patience or time to wait until the horse finds his way to suppleness and becomes connected through training. Instead, they frequently force the manufacture of a “beautiful” frame and demand what they want to have in front of them (round poll, elevation) with physical force. Much too late many riders realize that they cannot mechanically force suppleness and throughness. Experienced riders often feel and know intuitively that something isn’t right. But many riders and trainers don’t go as far as really admitting to themselves that they have made mistakes—possibly for years!

Trainers who already have much respectable success in competition find it especially difficult to take this step. “How can I be doing something wrong? I have won many Grand Prix!” Such thoughts are like a bullwark against recognizing that Classical Riding theory offers a sensitive path free of force. Because the horse must function, competitive sport ultimately doesn’t allow for taking the time to “smell the roses” or to dwell on Classical Riding teachings. Success is money, and money is more success. Why should there be any question? The suspicion of deficiency is repressed and covered up, and the trickery

begins. Frequently, it is self-induced pressure for success that keeps a rider from taking a clear, matter-of-fact look at correct riding. Naturally, the pressure is not just of our own making since success in the current system relies on satisfying customers and officials. There is no way around feeling the pressure of training within time limits.

PHYSICAL FORCE
IS NO SOLUTION
TO CONTACT
PROBLEMS!

I knew a trainer successful at the highest levels who regularly overpowered his horses in the worst way. When I challenged him one morning about a horse that he had strapped together with draw reins, the horse covered with foam and gasping for air, he replied, “They need this every couple of weeks!”

I also know that this is not an isolated case. The worst outbursts of force are daily business in many barns. However, I believe that these “attacks” are only very seldom really due to human character flaws. No doubt there is some despair involved, with the trainer not knowing what else he can do or how to extricate himself from a dead-end road.

Often these outbursts are the frustrated reactions to a horse that has long been ridden stiff and tight. Many riders break from this behavior pattern as they gain the knowledge that more force only takes them farther away from achieving a through horse.

A soft poll makes such emotional outbursts unnecessary.

WHAT IS A SUPPLE POLL?

Between the occiput and the first and second cervical vertebrae, there is a muscle system referred to as the *short head and neck muscles*. These

muscles allow movement of the head and the neck in the first two joints of the cervical vertebral column. A “soft” poll means complete suppleness of this

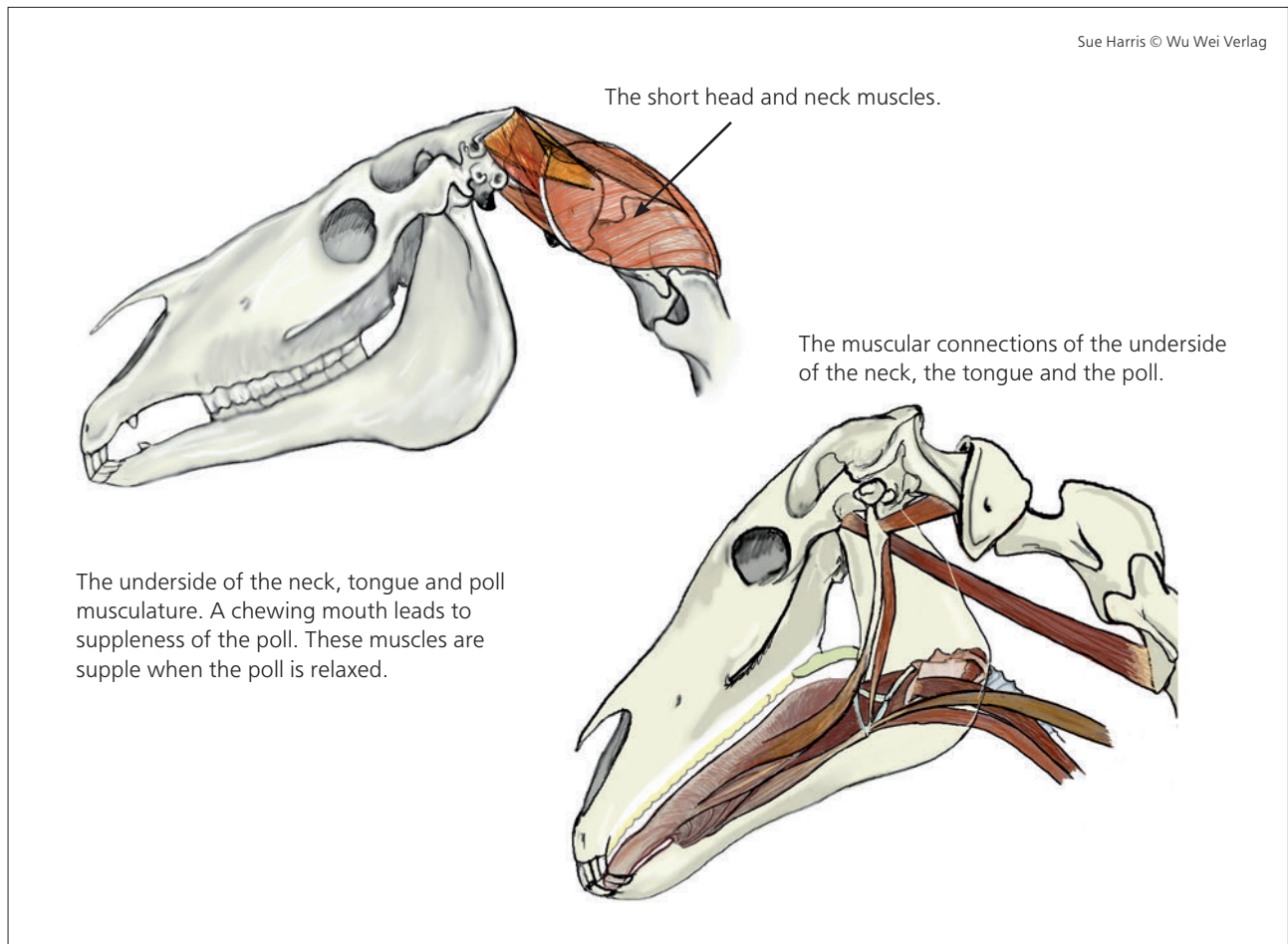

muscle system, which then overcomes resistances that make contact difficult. The horse willingly allows himself to be positioned in both directions, and to step up to the tactful rider's hand, relaxed and with a round poll.

At this point it should be clear that a relaxed poll never results from lowering the head against resistance from tight muscles at the top of the neck and the short head and neck muscles. A forceful pull against one or several muscle groups leads to complete cramping, which naturally leads to the back tensing up. On the other hand, tension in the poll results from a tight back, since the one inevitably

causes the other. The consequences of this understanding are clear: Both systems must be relaxed at the same time.

When our modern, young riding horses are put under saddle, they almost always react with defensive tension in the back, which in turn causes poll tension and over-rounding of the neck. If, at this stage, this over-rounding and "going behind the bit" is mistakenly interpreted as "going on the bit" or "giving at the poll," then the foundation has been laid for disturbance of a critical balance. Another horse needing "retraining" has just been created!

Forceful longitudinal flexion always, without exception, leads to cramping of the entire topline. This, in turn, leads unavoidably to the maximum possible disruption of balance, which causes negative consequences for training and for the health of the horse.

A horse can round his poll only as a result of his supple poll and back muscles.

SUPPLENESS OF THE POLL AND AN OPEN POLL ANGLE

The *positioning of the poll* is an indispensable prerequisite for correct bending. The diagonal aids, the leading outside rein and the driving inside leg, can only be established in a “positioned” horse. Positioning is only possible when the poll is relaxed and the poll angle is open. That requires the nose to be in front of the vertical. A horse with the nose behind the vertical rotates in the poll downward behind the vertical line. The nose points toward the chest, or at least backward. On the left and right side of the base of the skull, index-finger-long, bony processes (*Procc. paracondylares* or *procc. jugulares*) jut out caudally (to the back). When the poll flexes so that the nose goes behind the vertical, these bony processes lift under the wings of the first neck vertebra and block the poll from moving sideways. Positioning of the poll has then become anatomically impossible!

A horse going behind the vertical is less able to be positioned the smaller the poll angle gets.

With a narrow poll angle, the horse can only bend the whole neck to the side. In so doing, he breaks right in front of the withers. At the same time, the

short head and neck musculature over-stretches, cramps and loses all suppleness as a result.

In daily riding, it is understandably unavoidable that a horse will go deeper for a short time now and then. The tight-backed horse in retraining, a leg mover or an hyperflexed back mover is occasionally ridden with deeper neck flexion; this position can be tolerated for a short time. However, the rider should not purposely ask for this and should not consider it correct.

Statements such as “Make him through,” or “Put him deep,” are misunderstood concepts. In the worst case, the central message of the teachings of Classical Riding is turned on its head. It is not about pulling the head down, right or left. It is more about the horse going from his back end to his front end to the hand, seeking the contact in trust, and relaxing the back (see p. 69, Von Holleuffer on “swinging”). Only then will he give his poll and allow himself to be positioned equally to both sides. Consequently, the basic command reads:

The nose must be in front of the vertical!

This statement was, is and always will be correct, important and absolute!

If a rider wants to ride and train a balanced and through horse, there is not a single factual excuse for ignoring this command. A narrow poll angle doesn't allow the poll to be the highest point. A narrow poll angle prevents the horse from relaxing his back and arching it. Tension throughout the trunk musculature is inevitable. Naturally, the all important elasticity can't develop from such muscular tension. Consequently, the horse can't develop forward thrust and carrying power.

It is simply anatomically impossible to correctly train a horse with a narrow poll angle. The goal—throughness—is not achievable in this way. Certainly, such a horse is capable of mechanically performing the exercises that he has been taught since what is required is more or less the mechanical control of the flight reflex. In this regard, ethnologists speak of "learned helplessness." The horse must be psychologically broken, which everyone can surely imagine also leaves behind physical traces. It is not unusual for trainers to talk about a horse in this way: "This horse is a good horse. He tolerates everything." Seriously, I have heard this said often! Obviously, horses that don't resist rough training methods are more loved than those that self-confidently fight back!

She who believes a horse must be dominated with the hand will never experience how wonderfully light a through, balanced horse feels, and how much fun he is to ride!

The poll is a key juncture of the horse's whole body. Without a soft poll there cannot be a through horse. I would like to emphasize again: you cannot force the poll of a horse to be supple.

You "receive" a supple poll; you cannot "take" it!

Many authors have observed from experience that a tense poll always accompanies a back that doesn't swing. A horse without correct contact and without a supple poll will never be a back mover. When the poll appears to be supple as a result of exclusively manipulating the mouth, it still doesn't mean that the back has relaxed and that the horse is in balance. A leg mover or hyperflexed back mover (a Rollkur horse with an hyperflexed back) with a seemingly relaxed poll remains an unbalanced horse.

CONSEQUENCES FOR TRAINING

Suppleness of the poll must result from rhythmical movement in all three gaits. A yielding, relaxed poll requires that a horse swings in a relaxed fashion under the rider, and goes to the hand from back to front.

The order of the Training Scale components cannot be reversed! Without Rhythm, Suppleness, and Contact, you can't develop Impulsion, Straightness and Collection. The first three on the Scale are the foundation upon which everything else is built.

Everything that a rider wants “in front of her” when on her horse comes as a result of what she is able to achieve with her seat and sensitive hands as a means of communication. A stiff, tense seat with hard fists and tight shoulders always leads to a stiff poll, a tight back and tight haunches in the horse. The order of the first steps in the training of a young horse should read:

Supple, sensitive, balanced, appropriate seat (e.g. adjusted stirrup lengths) → sensitive, waiting, soft contact to the horse’s mouth with open neck and poll angles (nose in front of the vertical) → calm → feeling of rhythm → begin driving → rhythm → regular rhythm forward → suppleness → back begins to swing → rhythm improves with more dynamism and regularity → contact with a chewing mouth and a relaxed poll.

Basically it can be said:

Riding works only from the back to the front!

Never ride from the front to the back! In training for contact, the horse must play the active part and the rider’s hand the waiting, passive part. It is called, after all, “leaning to,” (the German word used for “contact” is *Anlehnung*, which literally means “leaning to”) not “pulling to.” A rider’s hand that is too active and overused leads to “disrupted” balance from the braking, backward action of the rider. A good, supple balanced seat and independent, quiet, sensitive hands are the foundation of good riding.

XXIV.

INITIAL STEPS IN RETRAINING

Part Three: The Hyperflexed Back Mover



THE HORSE WITH A “PUSHED UP” BACK



This overarched back is caused by an extremely low and deep-to-the-chest, forced head positioning (see photo on p. 198), or painful, self-protective tension in the horse's back (above).

A head-neck position that is much too deep is indicative of a horse that has “lost” his back, so to speak, *upward*: It becomes too high and thereby tense. This posture is what is meant by the *overstretched* or *hyperflexed back mover*.

The huge progress in breeding of the last decades has improved the rideability of horses so that young horses often start rounding the neck when first mounted. The short, round neck results from defensive tension in the back: Young horses push their back upward for their own protection against the weight of the rider.

I have already mentioned that this problem is something new in the last few decades, and is “self-protective” behavior. Every horse needs his neck long during the initial ground work phase and in the first training phases, in order to prevent damaging and unbearable back tension.

A young horse that curls his neck inward must be ridden rhythmically forward with relatively short stirrups and a light, forward seat.

Consistent forward riding will open the neck angle, and encourage acceptance of the bit. As a result, the previously raised back should drop and

relax. When the rider can start driving sensitively with her seat, improvement begins to be achieved.

Today, it is not uncommon to see numerous

horses purposefully trained with an extremely deep, round neck position as a means of gymnasticizing the horse.

“ROLLKUR“ AND HYPERFLEXION

The term “Rollkur” has been in modern usage since the late 1970s. It was used by a German riding sport magazine as a headline to an article by Professor Heinz Meyer on the subject of “deep head-neck position.” This word embodied a manner of riding with an extremely deep head-neck position with the nose curled toward the chest.

In 2006, a group of highly successful Rollkur “supporters” wanted the term changed to “hyperflexion.” At a meeting in 2010 in Lausanne, such aggressive training methods were officially disapproved. This resolution did not just refer to hyperflexion, but also to every form of mechanized, forced head positioning. Deep positioning without physical power and

force was recommended by the Dutch participants and referred to as the *LDR Method* (low, deep and round). This is a term that, while accepted, had no basis in logic. So, the FEI referred to this concept as “long, deep and round,” which at least made a little sense and was agreed upon with animal welfare in mind. A deep although not forced neck position assumed by the horse was not viewed as counter to animal welfare whereas forced longitudinal flexion—regardless of how high or deep—was regarded as unacceptable. The 2010 resolution accounted for the quality of training practices rather than limiting the time a horse is forced into longitudinal flexion. The revised wording, adopted by the FEI, included a

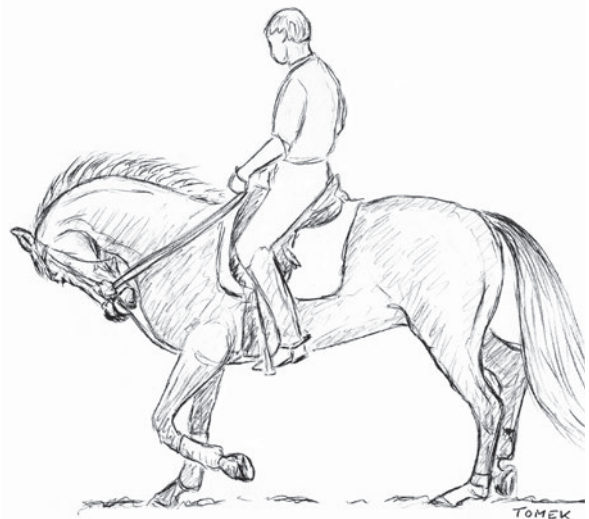

Forced longitudinal flexion of the horse is, in my view, a result of incorrect training of today's highly rideable young horses. This mechanized method of training leads to early injury.

depiction of the positions that are acceptable on the grounds of animal welfare in accordance with the

resolution. This 2010 decision is a first step in the right direction, with yet a long way to go.

LEARNED HELPLESSNESS

A mechanical, extremely deep longitudinal flexion—regardless of whether it is done with or without draw reins—is the worst possible thing for the back and balance of the horse. Most modern sport horses forced to move in such a posture start to run. They attempt to escape from the rider’s weight on their tight back much as a flight animal would with a predator on his neck. However, it is best if the horse is connected to the rider through an active, driving seat that influences and controls the horse. This stops the horse from running off.

When a horse suffers from an excessively tight back, the only way to stop him may be with strong use of the reins or by moving him as safely as possible toward an external object, like a wall. The emergency situation that requires stopping the fleeing horse by any means often leads to renewed and stronger use of the reins, with the horse’s head ending up on his chest. Physical power by the rider and exhaustion by the horse eventually lead to the horse becoming accustomed to this forced position.

The term “learned helplessness” was adopted from experts in behavioral research. They found that the flight reflex gradually decreases as the horse becomes more habituated—eventually he surrenders and gives up. But harmony and the relationship between horse and rider don’t stand in the center of the endeavor, only submission and servitude.

It is striking that when compared to far less well trained pleasure horses, the horses at the highest levels have to be prepared for competition through hours of riding. Multiple hour-long exhaustive riding procedures are common on the international sport scene, and are damaging to the horse. Too many horses “disappear” after a short appearance on the sport stage and are never seen again. Any horse presented at the highest levels of competition should only need a short and calm warm-up phase.

As I explain below, this curled-in neck and head-on-the-chest position leads to high tension emanating from the bit in the mouth to the back of the stifle.

EXTREME DISRUPTION OF BALANCE AND THE FLIGHT REFLEX

The entire topline of a horse in forced longitudinal flexion is overstretched; the back is lifted too high, locked and tense. The attachment from the back ligament to the sacrum “pulls up” the sacrum,

which overstretches the LS joint. Such incorrectly balanced horses develop a flat croup line through the constant pull on the rear attachment of the neck-back ligament.

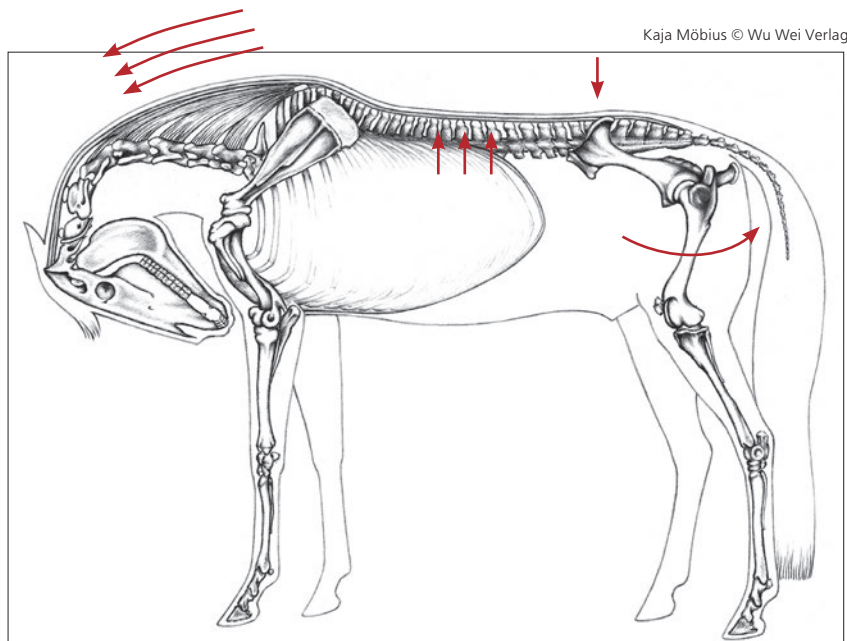

Horses with a neck that has been rounded by force always have a tight, straight back, a hyperflexed lumbo-sacral joint (LS; straight croup), hind legs that sprawl out behind, and stiff haunches.

This pulling up of the sacrum, the bony foundation of the pelvis, raises the entire pelvis caudally (toward the rear), thereby increasing tension on the gluteal muscles. The long gluteal muscles attach in the area of the back of the stifle. Subsequently, the stifle is pulled back due to increased pull from this muscle group; with the haunches stretched in place, so to speak. This poses an extreme disruption to the horse's balance, leading to the hind legs not being able to be brought forward naturally under

his body in the forward swing-phase. During the support-phase, the same effect occurs and the stifle joint can't spring forward at the moment the horse weights the corresponding leg. High negative tension in the upper muscle chain hinders the bending of the haunches. A horse tensed and positioned by force in this way can never be collected.

Psychologically, the horse responds to such back tension by "running away" from the rider's seat—the "flight effect" kicks in.

PSYCHOLOGICAL RELAXATION

As described in the last chapter, a primary step in retraining hyperflexed back movers is to encourage psychological relaxation and calm. A second retraining element is to reactivate the hind leg that

has become sluggish and inactive. Both steps have the goal of reestablishing the balance and returning mobility to the back. This is frequently a big problem: How does the rider drive a horse from her seat



Left and below left: Two successful dressage horses showing imbalance the moment the pictures were taken. Compare the piaffe on the left with the horse shown below. Below: A well-balanced horse in good collection with correct flexing of the haunches.

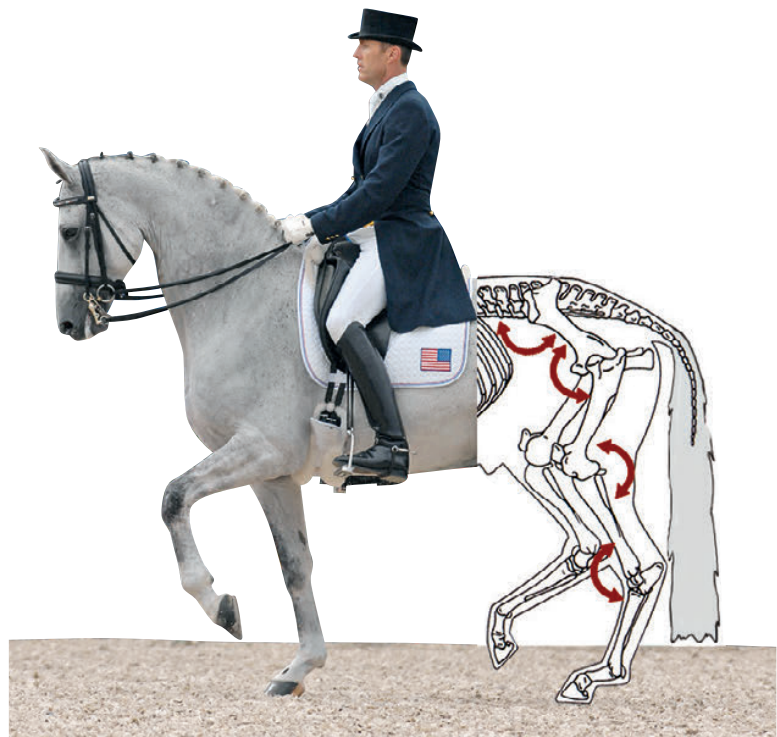

© Variation of a figure from Michael Strick's *Denksport Reiten*, FN Verlag, Warendorf, 2001

when the horse is already “running away” from her aids? The problem often gets so bad that the horse that has been mistreated in this way is considered unrideable. The horse has learned to use his board-

like, “blocked” back as a weapon against the rider’s weight. It could even be life-threatening to get on such a horse!

LONGEING WITH A CAVESSON

Longeing with a cavesson plays an indispensable role in defusing the initial flight reactions in horses that truly have become dangerous. The horse should be allowed to gallop forward energetically after an appropriate warm-up phase, and for as long as necessary until the initial and greatest tension is released. Going forward in this way may be necessary for a few days to as long as a few weeks! The rider should only mount the horse and begin work in the saddle once the horse tolerates her weight without any “defensive” tension appearing. It is at this

point that the retraining process can be continued.

Rhythmical and lively forward work must be very consistent. The horse must be allowed to use his neck; value is placed on a long, almost horizontal neck. From a biomechanical point of view, the goal of training is the same as for other horses being retrained: suppleness of the back. Energy in the hindquarters and suppleness of the long back muscles are synergistic. Rollkur (hyperflexed) horses are sometimes extremely tense, very fearful and often unpredictable, depending on the extent of the



Longeing in a cavesson is used to physically and mentally relax the tense horse.

physical and psychological damage. These horses are ones that may benefit well from regular cross-country riding (see p. 194).

A first stage goal is to reestablish natural balance, which is part of the first three steps of the Training Scale: Rhythm, Suppleness, Contact.

VERY DIFFICULT HORSES WITH A FLIGHT TENDENCY

Retraining a horse that has been mistreated in this way for a long time is often very difficult. In my experience, these are horses that will react to even a light seat with flight. They run randomly against the rider's hand and can only be stopped by rough action of the reins with no fulfillment of any elements of the Training Scale, which means there is no Rhythm.

There is another way forward with such horses. After an appropriately long walk phase (very long!) the experienced and softly seated rider allows the horse to trot while she tries to stay soft and light in

short stirrups, and above all, find a very calm tempo. The tempo should resemble a Western jog. It is especially important to sit lightly and steadily and to try to lengthen the horse's neck. At first, the horse may attempt to curl his neck in as an evasion, move with a quasi leg-yield—an undefined sideways motion. I work such horses in this quiet tempo on curved lines and sit very quietly, almost passively, until I sense that the horse is beginning to stay with me: Wait for your horse! I use these moments to lighten my seat and then to sit down again. If the horse stays with me



When retraining is dangerous because the horse manifests self-protective mechanisms like rearing or bucking, longeing with a cavesson is a good starting point to remove, or at least lessen, his defensiveness.

and accepts sensitive driving in a forward seat, we have come a long way. I remember a mare that took three months to relax!

To be able to correct such a horse, a rider needs experience, inner calm and above all, endless patience.

At the beginning, I never rode this mare two days in a row in order to avoid her getting a muscle cramp that could become an “enemy” to progress. Additionally, she was in the pasture all day with the herd.

RESISTANCE AGAINST THE RIDER’S LEG

A horse with a tense back, whether due to active hands (hyperflexion) or through curling the neck in on his own, frequently exhibits a further symptom: not accepting the rider’s leg. The pattern runs from resistance to the leg, mostly on the horse’s stiff side, and being dull to the leg on the hollow side, to massive attacks: Such horses can kick out against the rider’s leg or energetically back up as soon as the rider attempts to use it. When the strongest movement muscle of the back (the long back muscle) is tense, then the corresponding antagonist (above all, the external oblique abdominal muscle) reacts the same way: A tense back results in a tense abdomen. According to the temperament of the horse and the degree of his tension, there will be varying degrees of resistance to the leg.

Reestablishing natural balance is the essence of retraining. The horse must “get his neck back”—that is, he must learn how to stretch to the bit and to accept the bit farther forward. The horse with a short, curved neck poses a problem that is best corrected by a sensitive and experienced rider. She must be good at the light seat in trot and canter and be versed in careful and slowly developed forward riding. Be careful! These horses frequently—and happily—buck at the canter not because they are being bad but instead, it’s a sign of beginning suppleness.

When such a horse has found his balance and relaxed his back, it is generally easy to get him accustomed to the leg aids.

THE INTERPLAY OF THE AIDS

On this subject, I’ll touch briefly on the basics of giving the aids. The Classical Training philosophy builds on a feeling that communicates the difference between *driving* and *holding* aids. The better the horse is trained, the more important the rider’s seat. When this goal of influencing the horse via the rider’s seat is achieved, rein and leg aids move more to a supporting role, becoming lighter and lighter

until finally, they function simply as organizers. At the same time, coordination of seat, leg and rein aids becomes more demanding. To ride a halt on a horse with a yielding poll requires the coordination of all forms of influence!

A separation of the aids, as in leg without hand and hand without leg, only makes sense with young horses and horses in retraining.

A driving aid is not likely to be successful when coupled with a holding or taking rein in a horse with a tight poll and back. In this case, it makes sense to separate these aids. A horse in correct balance, without poll resistance or back tension, should be worked with finely tuned coordination of the driving and holding aids.

A strict separation of the aids is found only in training philosophies that are not based on a horse with a “carried” and supple back. This is acceptable when

the horse is in a different balance, namely moving with a deep, loose back and lightly hanging reins without impulsion from the hindquarters (*Légèreté*). As soon as the upper muscle chain (rider hand → chewing musculature → poll → neck’s topline → back → croup → buttock muscles) is positively tensed through a correct contact, the horse is “through” and accepts the interplay of the aids. Horses that require a separation of the aids are not back movers in the sense of the Classical Training philosophy!

RECOMMENDATIONS FOR RETRAINING

To summarize, the following can be recommended for retraining the hyperflexed back mover:

- Be careful when riding an extremely tense horse. Hyperflexed back movers are often unpredictable. They are physically and psychologically extremely tense!
- An extremely tight back can be loosened up quite well through expert longeing in a cavesson.
- It is very important to have a long neck with the poll being the highest point. Horses must be lifted up if the poll sinks too low.
- Riding forward in a regular rhythm is key. You must be able to drive with an active, supple seat.
- Correct driving from a sensitive calf and an encouraging seat staying supple activates a lazy hind end. (Be careful since a stiff seat blocks the back—so, no “braced” seat!) Incorrect driving is when the rider stiffens and braces her back.
- Find the horse’s unique and individual rhythm.
- When possible, ride regularly out in the country, up and down hills and at an eager forward canter, always being cautious about your safety.
- Mobility and suppleness of the horse’s back determine when the Training Scale work can begin.