



Projector Manual



10 Watt LED Gobo Projector

Manual updated 08/04/24

All gobo projector information can be viewed via www.projectedimage.com via the product page for this item. If any further information is required, contact via email to gobo@projectedimage.com



Introduction	...03
Dimensions	...04
Gobo Information	...05
Gobo Replacement	...05
Safety Information	...06
Installation Information	...08
Driver and AC Information	...09
Maintenance and Cleaning	...10
Fixture Overview	...11
Terms and Conditions	...12
Returns Policy	...12



General Information

The Projected Image 10 Watt LED is a dynamic effect lamp that projects sharp images from user-supplied glass or metal 37.5mm gobos. It has a 10W LED engine with long-life white LEDs.

The fixture is supplied with this user manual, a 1.9 m (6 ft.) power cable, an adjustable mounting bracket / floor stand, a gobo of your choice mounted in the gobo holder.

Before Using the Product

1. Read 'Safety information' on pages 6 and 7 before installing, operating or servicing the fixture.
2. Unpack and ensure that there is no transportation damage before using the fixture. Do not attempt to operate a damaged fixture.
3. If the fixture is not going to be hard-wired to a mains supply, install as directed in this manual a local power plug (not supplied with EU model) on the supplied power cable.
4. Before operating, ensure that the voltage and frequency of the power supply match the power requirements of the fixture.
5. Check the Projected Image website at www.projectedimage.com for the most recent user documentation and technical information about the fixture.

Detailed Information

Ultra bright 10W Cree LED

2000 lumens and 7500K colour temperature

Lamp life:

50000 hours

Projector lens:

20 Degrees

Material:

Rustproof aluminium alloy.

Input:

100V - 240V / 50 - 60 Hz

Working temperature:

-20°C to 50°C

Gobo Size:

Outer diameter: 37.5mm

Image Diameter: 25mm

Recommended projection distance:

Maximum 8 metres in dim/dark situations, 4 metres in normal indoor situation (office / shop lighting)

Manual focus lens, ensuring clear projection at all distances.

INDOOR USE ONLY

One-year warranty

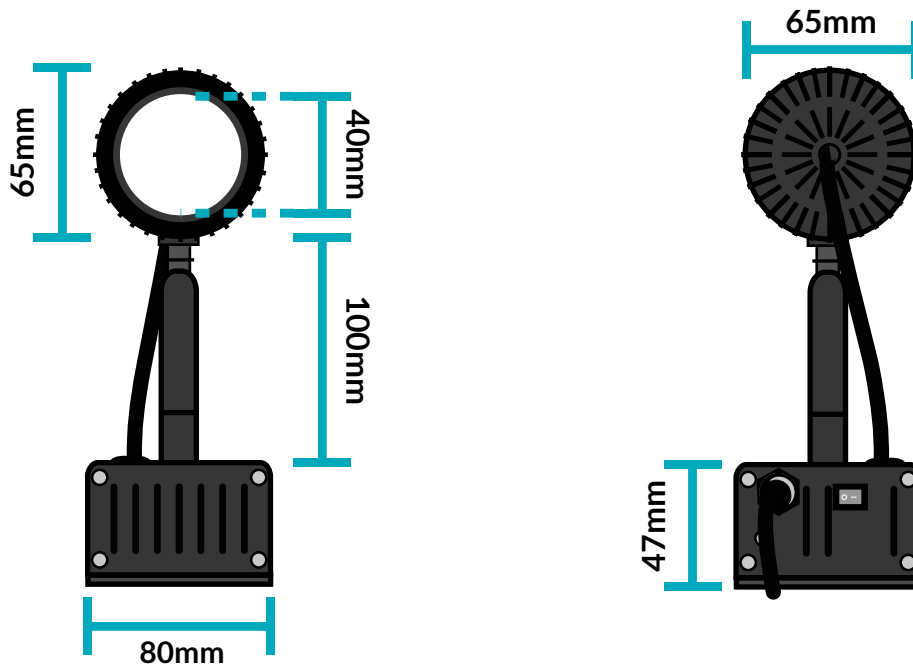

Front View

Rear View

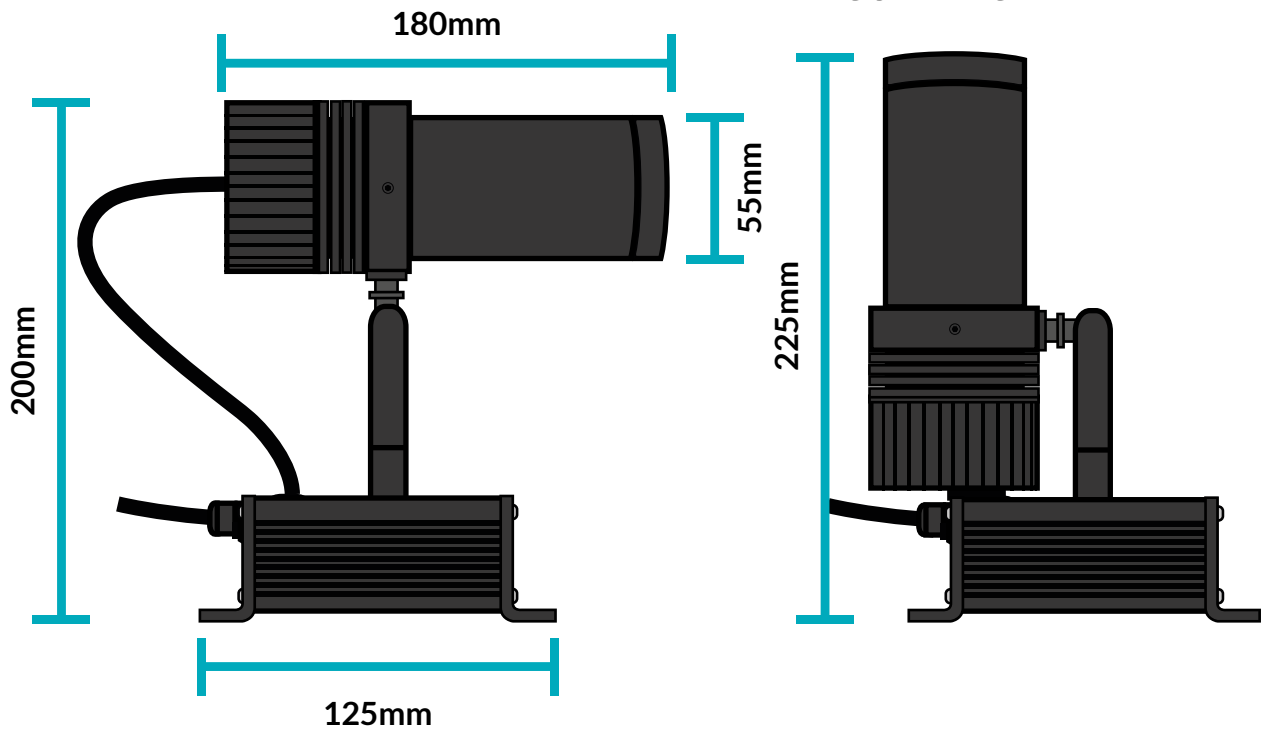

Horizontal

Vertical



Monochrome Glass Gobo

Colour Glass Gobo

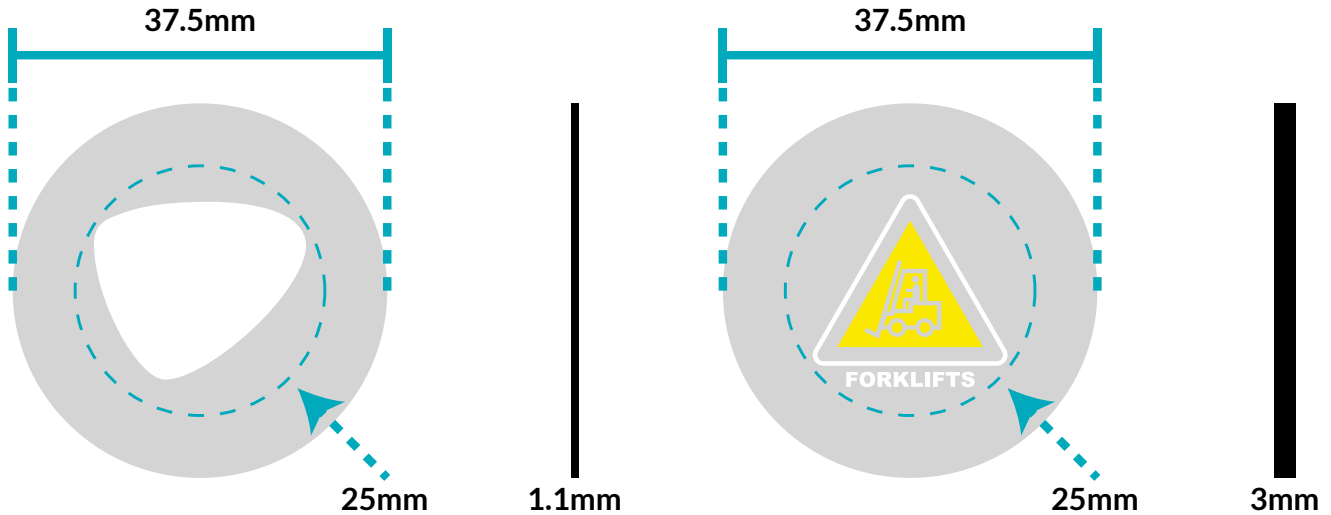

Above are the Outer Diameter, Safe Area and Gobo Thicknesses for monochrome and colour gobos. Metal gobos can also be used, manufactured to the same dimensions. Do not use film gobos.



[Video Demonstration](#)

Gobo Replacement

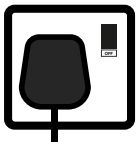

Turn off the unit and leave for 20 minutes, allowing the unit to cool before touching.

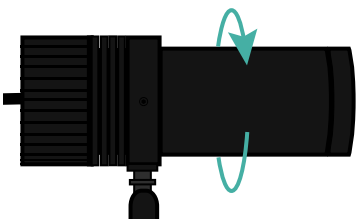

Side View

Turn counter-clockwise to remove Lens Carrier from the main body of the projector

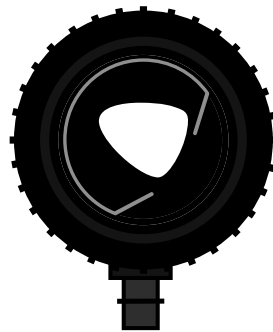
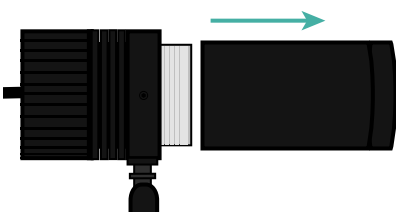

Front View

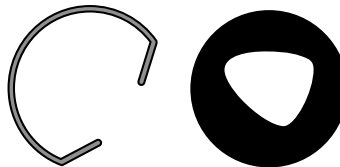
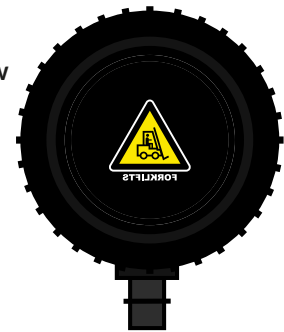

Gobo Clip

Gobo

Pinch the raised edges of the gobo clip and remove. With a gobo pen or latex gloves, remove the gobo from the projector.



Gobo Clip

Place the new gobo into the projector, with the silver shiny side towards the LED. Add the clip back to the unit, and screw the lens carrier back on.

Gobos can be purchased via www.projectedimage.com as either monochrome glass gobo or a colour glass gobo.

If you require a custom design, or have any questions with regards to the information on this page, please email us at gobo@projectedimage.com.



Read the safety precautions in this manual before installing.

The following symbols are used to identify important safety information on the product and in this manual:



Warning!
Safety hazard. Risk of severe injury or death.



Warning!
Powerful light emission. Risk of eye injury.



Warning!
See user manual for important safety information.



Warning!
Risk Group 2



Warning!
Hazardous voltage. Risk of lethal or severe electric shock.



Warning!
Hot surfaces and fire hazard.

Do not stare directly into the beam. Do not view the light output with optical instruments or any device that may concentrate or focus the the beam. See safety standards here - http://smartvisionlights.com/wp-content/uploads/pdf/IEC_62471_summary.pdf

This lighting fixture is for professional use only – it is not for household use. The fixture must be installed by a qualified person. The safety of the installation is the responsibility of the installer. The fixture presents risks of severe injury or death due to fire hazards, electric shock and falls. It produces a powerful, concentrated beam of light that can create a fire hazard or a risk of eye injury if the safety precautions below are not followed.

If you have any questions about how to install, operate or service the fixture safely, please contact us on +44 (0) 191 265 9832 or on gobo@projectedimage.com.

Respect all locally applicable laws, codes and regulations when installing, operating or servicing the fixture.

There are no user-serviceable parts inside the fixture. Do not open it. Refer any service or repair operation not described in this manual to an authorised lighting service technician or return to us. Do not try to carry out any such operation yourself, as doing so may present a health or safety risk. It may also cause damage or malfunction and it may void your product warranty.

Install, operate and service the Projected Image 10 Watt LED projector only as directed in the user manuals, or you may create a safety hazard or cause damage that is not covered by product warranties.

Follow the safety precautions listed below and observe all warnings in this manual and printed on the product.

Keep this user manual for future use. If you sell the product, give this manual to the new owner.

For the latest user documentation and other information for this and all Projected Image products, please visit the Projected Image website at www.projectedimage.com



Protection from Electric Shock

Do not expose the fixture to rain or moisture. Disconnect the fixture from AC power before carrying out any installation or maintenance work and when the fixture is not in use.

Ensure that the fixture is electrically connected to ground (earth).

Use only a source of AC power that complies with local building and electrical codes and has both overload and ground-fault (earth-fault) protection. Socket outlets or external power switches used to supply the fixture with power must be located near the fixture and easily accessible so that the fixture can easily be disconnected from power.

Isolate the fixture from power immediately if the power plug or any seal, cover, cable, or other component is damaged, defective, deformed, wet or showing signs of overheating. Do not reapply power until repairs have been completed.

Before using the fixture, check that all power distribution equipment and cables are in perfect condition and rated for the electrical requirements of all connected devices.

The supplied power input cable is rated 6 A. If you replace this cable, the replacement cable must also be rated 6 A minimum, have three conductors 18 AWG or 0.75 mm² minimum conductor size, have an outer cable diameter of 6 - 15 mm (0.2 - 0.6 in.) and be temperature-rated to suit the application. In the USA and Canada the cable must be UL listed, type SJT or equivalent. In the EU the cable must be type H05VV-F or equivalent.

Protection from Burns and Fire

Do not use the fixture to illuminate surfaces within 200 mm (7.9 in.) of the fixture. Do not operate the fixture if the ambient temperature (T_a) exceeds 40° C (104° F).

The surface of the product casing can reach up to 60° C (140° F) during operation. Avoid contact by persons and materials. Allow the fixture to cool for at least 15 minutes before handling.

Keep flammable materials well away from the fixture. Keep all combustible materials (e.g. fabric, wood, paper) at least 100 mm (4 in.) away from the fixture. Ensure that there is free and unobstructed airflow around the fixture. Provide a minimum clearance of 100 mm (4 in.).

Do not attempt to bypass thermostatic switches or fuses.

Do not stick filters, masks or other materials onto any optical component.

Use only glass or metal gobos. Do not insert film, plastic, paper, or any other flammable material in the gobo holder.

Protection from Injury

Fasten the fixture securely to a fixed surface or structure with a minimum of two permanent fasteners. Do not fasten with clamps. The fixture is not portable when installed.

Ensure that any supporting structure and/or hardware used can hold at least 10 times the weight of all the devices they support.

Check that all external covers and rigging hardware are securely fastened.

Do not operate the fixture with missing or damaged covers, shields or any optical component. If shields, lenses or ultraviolet screens have become visibly damaged to such an extent that their effectiveness is impaired, for example by cracks or deep scratches, please contact Projected Image.

Block access below the work area and work from a stable platform whenever installing, servicing or moving the fixture.

In the event of an operating problem, stop using the fixture immediately and disconnect it from power.

Do not attempt to use a fixture that is obviously damaged.

Do not modify the fixture in any way not described in this manual or install other than parts supplied by Projected Image.

Protection from Eye Injury

Do not stare directly into the light output. Ensure that persons are not looking directly into the LEDs when the product lights up suddenly. This can happen when power is applied.

Do not look at the light output with magnifiers, telescopes, binoculars or similar optical instruments that may concentrate the light output.

To minimize the risk of eye irritation or injury, disconnect the fixture from power at all times when the fixture is not in use, and provide well-lit conditions to reduce the pupil diameter of anyone working on or near the fixture.



Physical installation

Read 'Safety information' on pages 6 and 7 before installing the fixture.

The fixture is designed for indoor use only. It must be used in a suitable location and provide adequate ventilation. The fixture presents risks of severe injury or death due to fire hazards, electric shock and falls and is not intended for truss mounting or installation with rigging clamps. The fixture must be installed and maintained only by qualified personnel or electricians with experience in lighting equipment and general electrical experience. The safety of the installation is the responsibility of the installer.

Locate the fixture at least 10 cm (4 in.) from adjacent surfaces.

Fasten the fixture to a secure structure or surface. Do not stand it or leave it unfastened where it can be moved or fall over. When suspending the fixture above ground level, verify that the structure can hold at least 10 times the weight of all installed devices.

The fixture can be fastened to a hard, fixed, flat surface that is oriented at any angle. Ensure that the surface and all fasteners used can support at least 10 times the weight of all fixtures and equipment to be installed on it.

Fasten the fixture securely with four screws (not supplied) inserted through the 7 mm (1/4 in.) curved mounting slots in the mounting bracket as shown.

Use at least four screws for installation.

The units should be fitted by a qualified electrician only.

Below are some examples of placement.

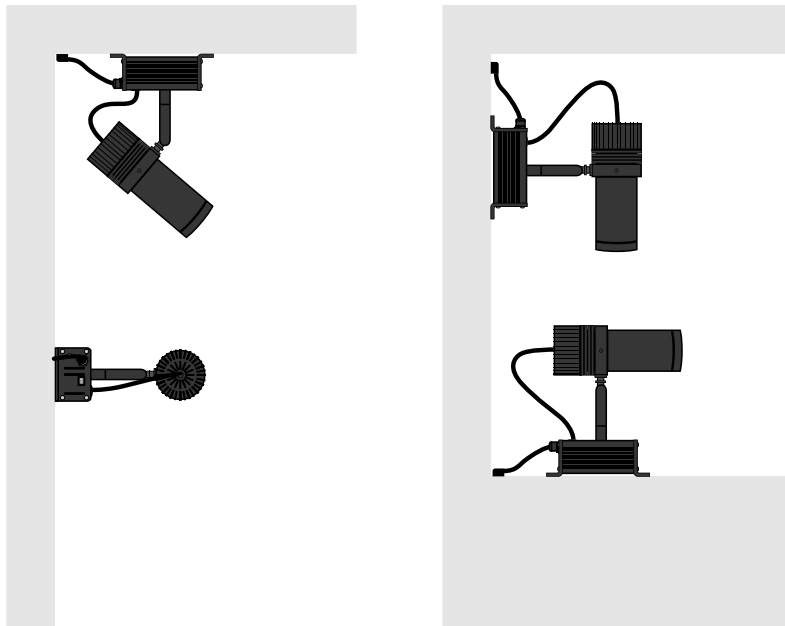

DO NOT

- Submerge any part of the unit under water.
- Place the units under any kind of water source or where a direct flow of water may appear.
- Place in the reach of the public or near a direct heat source.
- Stare directly into the light source.
- Position the unit in direct line of public or vehicles where vision can be affected.
- Cover the unit with any kind of plastic or flammable material.

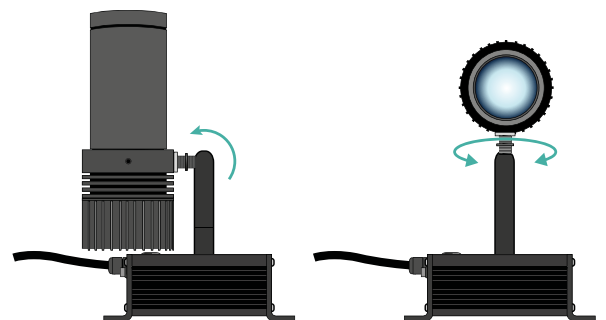
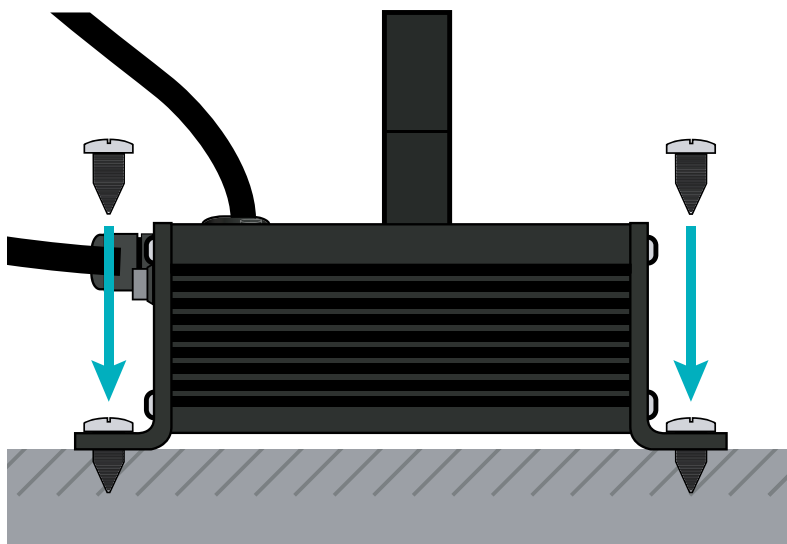

This unit can be rotated 360° Horizontally and 90° back. This allows for projections from many angles via the ball joint.



Driver Specifications

Input		
Input Voltage Range	Frequency Range	AC Current
85~265VAC	50/60Hz	0.285/110VAC, 0.163/230VAC

Output			
Output Voltage	Rated Current	Rated Power	Voltage Tolerance
24-36V	0.25A	10W	±5.0%

Socket outlets or external power switches used to supply the fixture with power must be located near the fixture and easily accessible so that the fixture can easily be disconnected from power.

Connecting the fixture to a switched AC mains circuit provides a convenient way to power the fixture on and off. Do not use an external dimming system to supply power to the fixture, as this may cause damage to the fixture that is not covered by the product warranty. The fixture can be hard-wired to a building electrical installation or a power plug (not supplied with the EU model) that is suitable for the local power outlets can be installed on the power cable.

If you install a power plug on the power cable, install a grounding type (earthed) plug with integral cable grip that is rated minimum 250 V, 6 A. Follow the plug manufacturer's instructions and connect the wires in the power cable as shown in this table:

	Live / L	Neutral / N	Ground / Earth
US System	Black	White	Green
EU System	Brown	Blue	Yellow / Green

The fixture has an auto-ranging power supply that accepts AC mains power at 100V~240V, 50/60Hz. Do not apply AC mains power at any other voltage or frequency to the fixture.



Maintenance

Warning! Read 'Safety information' before servicing the fixture.

Refer any service operation not described in this user manual to a lighting technician.

Disconnect mains power before cleaning or servicing the fixture.

Service fixtures in an area where there is no risk of injury from failing parts, tools or other materials.

Cleaning

Excessive dust, smoke fluid, and particle buildup degrades performance, causes overheating and will damage the fixture. Damage caused by inadequate cleaning or maintenance is not covered by the product warranty.

The cleaning of external optical lenses must be carried out periodically to optimize light output. Cleaning schedules for lighting fixtures vary greatly depending on the operating environment. It is therefore impossible to specify precise cleaning intervals for the fixture. Environmental factors that may result in a need for frequent cleaning include:

- Use of smoke or fog machines.
- High airflow rates (near air conditioning vents, for example).
- Presence of cigarette smoke.
- Airborne dust and dirt.

If one or more of these factors is present, inspect fixtures within their first 100 hours of operation to see whether cleaning is necessary. Check again at frequent intervals. This procedure will allow you to assess cleaning requirements in your particular situation. If in doubt, please contact Projected Image about a suitable maintenance schedule.

Use gentle pressure only when cleaning, and work in a clean, well-lit area. Do not use any product that contains solvents or abrasives, as these can cause surface damage.

To clean the fixture:

1. Disconnect the fixture from power and allow it to cool for at least 15 minutes.
2. Vacuum or gently blow away dust and loose particles from the outside of the fixture with low-pressure compressed air.
3. Clean the surfaces by wiping gently with a soft, clean lint-free cloth moistened with a weak detergent solution. Do not rub glass surfaces hard: lift particles off with a soft repeated press. Dry with a soft, clean, lint-free cloth or low-pressure compressed air.
Remove stuck particles with an unscented tissue or cotton swab moistened with glass cleaner or distilled water.
4. Check that the fixture is dry before reapplying power.



Specifications

Horizontal Position: 180mm Length, 200mm Height, 80mm Width.

Vertical Position: 140mm Length, 225mm Height, 80mm Width

Weight: 1.5 Kg

Gobo Projection: Static

Gobo Specifications: 37.5mm Outer Diameter, 25mm Image Area, Maximum Thickness: 3mm

Gobo Material: Glass or metal

Lens: 20° Beam Angle, Manual Focus

Light Source: 10W LED Array

Lumens: 2000 lumens

Colour Temperature: 6000K

Minimum LED lifetime*: 30 000 hours (to >70% luminous output) *Figure obtained under manufacturer's test conditions

Mounting: Surface or floor mount

Location: Indoor use only, must be fastened to surface or structure

Driver AC Input: 85~265VAC at 50/60Hz

Supplied with Type G Plug (UK Electrical Plug) as Standard

Cooling: Convection

Maximum ambient temperature (Ta max.) - 40°C

(104°F) Minimum ambient temperature (Ta min) - 0°C

(32°F) Total heat dissipation* - 65 BTU/hr.

*Calculated, +/- 10%

Safety Standards:

EU safety - EN 60598-2-17 (EN 60598-1), EN 62471, EN 62493 EU EMC - EN 55015, EN 55032, EN 55103-2, EN 61000-3-2, EN 61000-3-3, EN 61547

US safety - UL 122

US EMC - FCC Part 15 Class A

Canadian safety - CSA C22.2 No. 118-1959 Canadian

EMC - ICES-003 Class A Australia/NZ - C-Tick N4241

Projector Box Items

20° Lens

Custom gobo in gobo holder / Projector

Gobo holder clip

Power cable, 1.9 m (with mains plug)

Disposing of this product

Our products are supplied in compliance with Directive 2012/19/EC of the European Parliament and of the Council of the European Union on WEEE (Waste Electrical and Electronic Equipment), where applicable. Help preserve the environment! Ensure that this product is recycled at the end of its life. Your supplier can give details of local arrangements for the disposal of this product.

Photobiological Safety Warning

The label shown below is displayed on this product. If it becomes difficult or impossible to read, it must be replaced using the illustration below to reproduce a new label sized 45 × 18 mm, in black on a yellow background.

RISK GROUP 2 CAUTION. Possibly hazardous optical radiation emitted from this product. Do not stare at operating lamp. May be harmful to the eyes.



Risk in and Ownership of the Goods

Risk in the Goods shall pass to the Buyer on delivery. Ownership in the Goods shall not pass to the Buyer until the Company has received in full in cleared funds all sums due to the Company in respect of the Goods and all other sums which are or may become due to the Company from the Buyer on any account. Until ownership of the Goods has passed to the Buyer, the Buyer shall: hold the Goods on a fiduciary basis as the Company's bailee store the Goods separately from all other goods of the Buyer or any third party in such a way that they remain identifiable as the Company's property not destroy or deface any identifying mark on the Goods or their packaging maintain the Goods in satisfactory condition insured with the Company's interest noted on the policy and hold any proceeds of such insurance on trust for the Company and not mix them with any other money.

Warranties

The Company warrants that the Goods are of satisfactory quality.

If the Buyer wishes to make a claim under this warranty, the Buyer shall give written notice to the Company within 30 days of the discovery of the defect and give the Company a reasonable opportunity to inspect the Goods in question. The Company shall not be liable for any breach of warranty if the Buyer makes any further use of the Goods after giving such notice or alters or repairs the Goods without the agreement of the Company. The Company shall not be liable for any breach of warranty if the Buyer fails to handle the Goods in accordance with the Company's handling and installation instructions.

Furthermore, the Goods must be installed by an appropriately qualified technician in accordance with the specifications of any projection or lighting equipment.

The Company's liability under the warranty shall be limited to repairing or replacing the Goods in question or refunding the price of such Goods.

Exchange and Returns

The Company warrants that the goods are of satisfactory quality. If the Buyer is not satisfied with the Goods as laid out in the Contract, the Company may at its sole discretion offer to exchange or re-manufacture said Goods. This is subject to the provisions laid out in paragraph 7 relating to the correct handling and Installation of the Goods.

Returns Policy

1. All of our projectors come with a 1 year warranty.
2. Goods are NOT supplied on a trial basis.
3. If found to be faulty from new they can be returned for replacement or refund. Please email us as soon as a fault is found.
4. You have the right to return up to 14 days from the day delivery has been made. Goods that have been made to order or to a chosen specification (i.e Gobos) or that have been opened/unsealed cannot be returned under the 14 day "Cooling Off Period".
5. You must provide us with written notification either by letter or email giving details of the goods ordered and their delivery where appropriate.
6. Once we have been notified, you must return the goods immediately. You must either return the goods at your own expense or we can arrange collection of the goods via our courier for a fixed fee.
7. The goods must be returned to us in the same condition they were sent out in.
8. Once you have notified us that you wish to return the goods we will refund or credit you as soon as possible, but in any event within 30 days, for any sum that has been paid by you for the goods excluding any extra charges incurred by us at your request, such as Express Delivery Etc.
9. You have a duty of care under these terms to take good care of the goods so that they may be sold again as new. We will claim from you for any resulting loss in value for goods not kept in such a condition that they may be sold again as new.
10. Refunds will be done within 30 days from cancellation as long as goods have been returned and the sections above have been followed. If the goods have not been returned refund will not be processed until after the goods have been returned.
11. Limitation of Liability

The Company's liability in contract, tort or otherwise arising out of the subject matter of the Contract shall not exceed £1,000 and the Company shall under no circumstances be liable to the Buyer for any consequential, indirect or economic loss or damages.