

ASSEMBLY INSTRUCTION

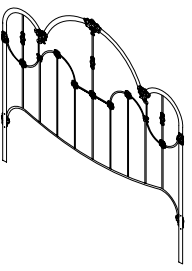

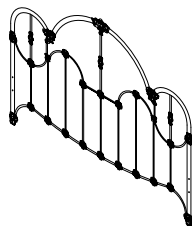

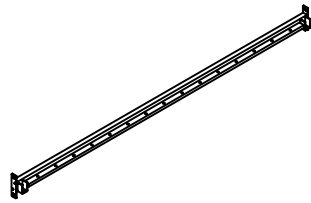

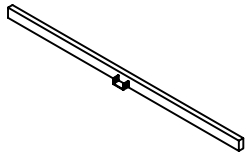
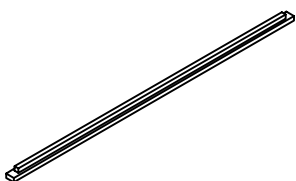
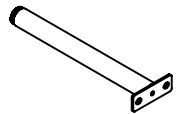
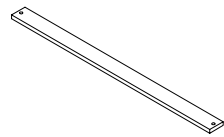



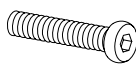

DO NOT OVER TIGHTEN SCREWS UNTIL COMPLETELY ASSEMBLED

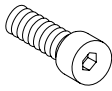

PARTS LIST

<p>1</p>  <p>1</p>	<p>2</p>  <p>1</p>	<p>3</p>  <p>2</p>	<p>4</p>  <p>2</p>
<p>5</p>  <p>1</p>	<p>6</p>  <p>1</p>	<p>7</p>  <p>15</p>	

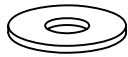
HARDWARE LIST

<p>A</p>  <p>16mm Metal Washer</p> <p>10</p>	<p>B</p>  <p>M6*16mm Screw</p> <p>6</p>	<p>C</p>  <p>M6*73mm Screw</p> <p>2</p>	<p>D</p>  <p>M6 Nut</p> <p>2</p>	<p>E</p>  <p>Slats Clip</p> <p>30</p>	<p>F</p>  <p>M6 Plastic Regulate</p> <p>1</p>
<p>G</p>  <p>4mm Allen Key</p> <p>1</p>	<p>H</p>  <p>6mm Open End Wrench</p> <p>1</p>	<p>I</p>  <p>M8*30mm</p> <p>8</p>	<p>J</p>  <p>18mm Metal Washer</p> <p>8</p>	<p>K</p>  <p>18mm Metal Washer</p> <p>8</p>	<p>L</p>  <p>6mm Allen Key</p> <p>1</p>

ASSEMBLY INSTRUCTION

STEP 1

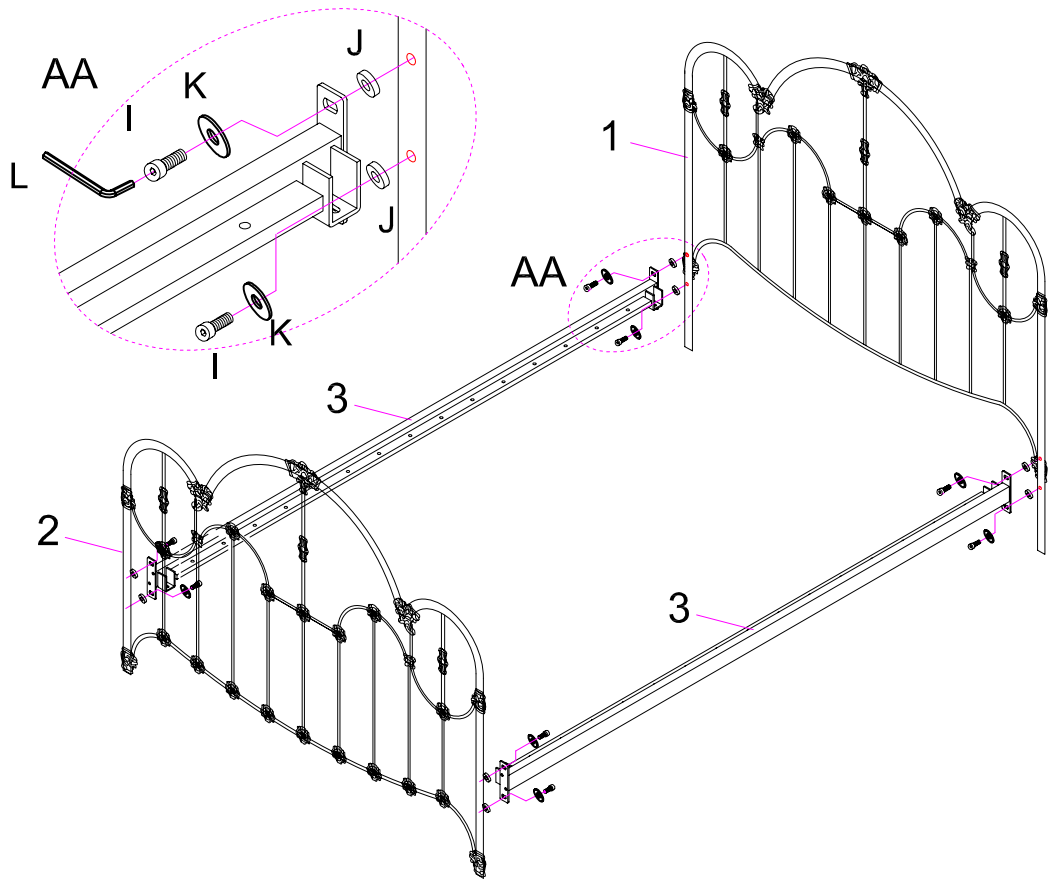

STEP 2

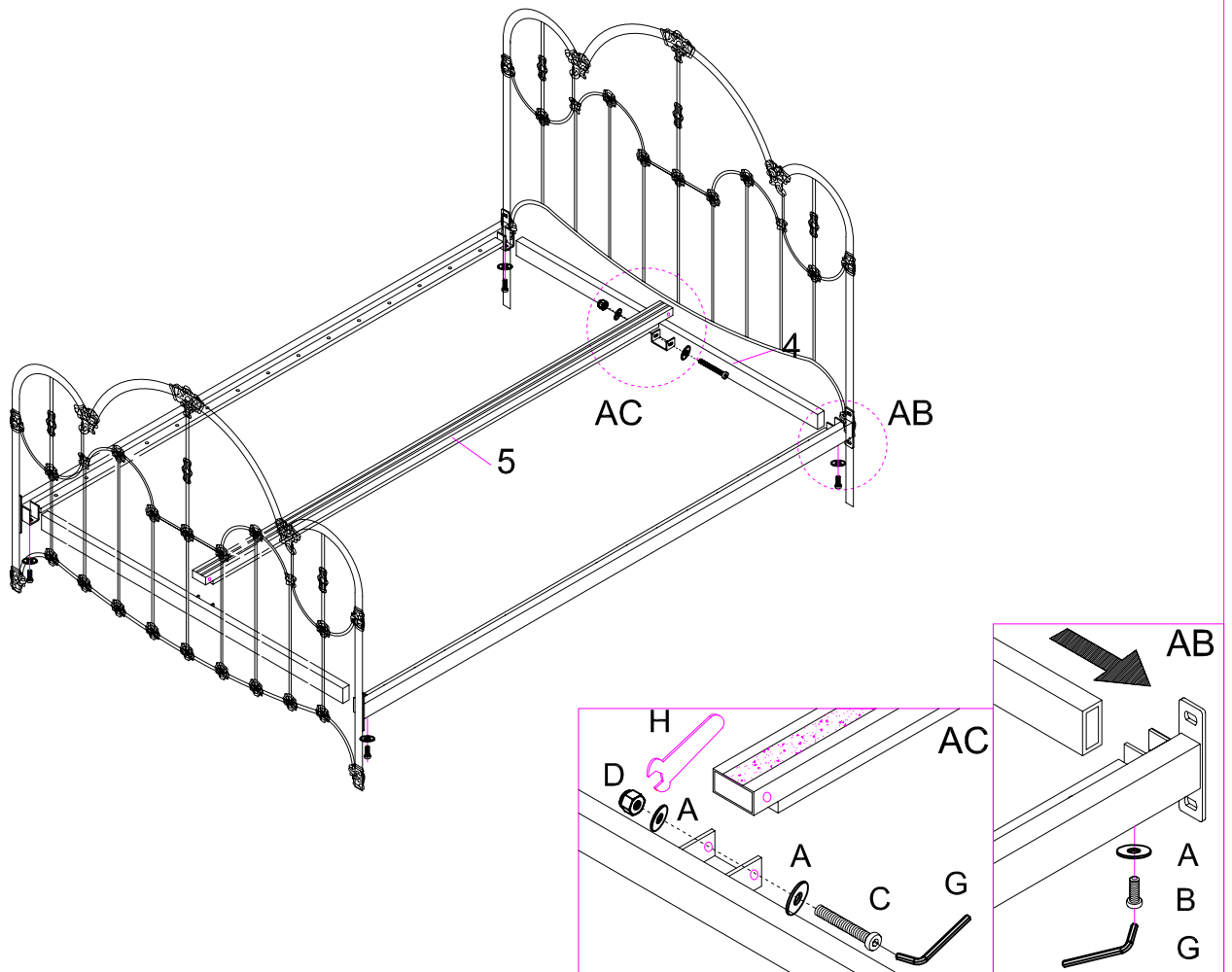

ASSEMBLY INSTRUCTION

STEP 3

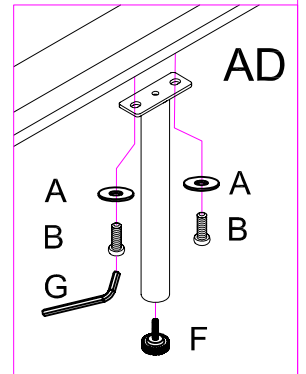
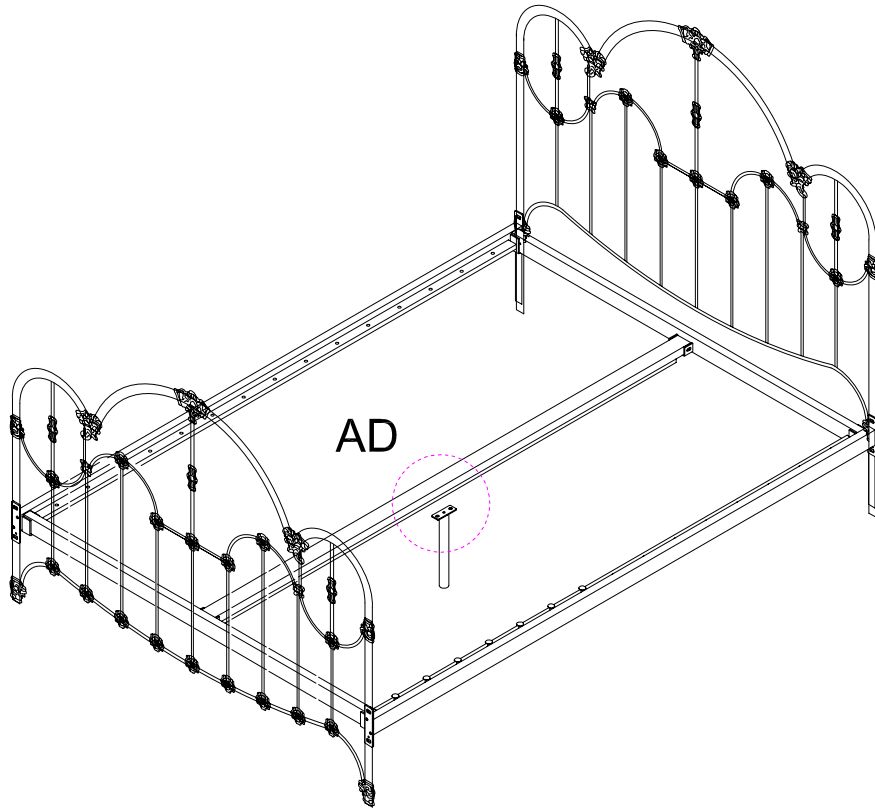

STEP 4

