

# AU1089 & AU1090 & AU1091 & AU1092 Bed

## Assembly Instructions

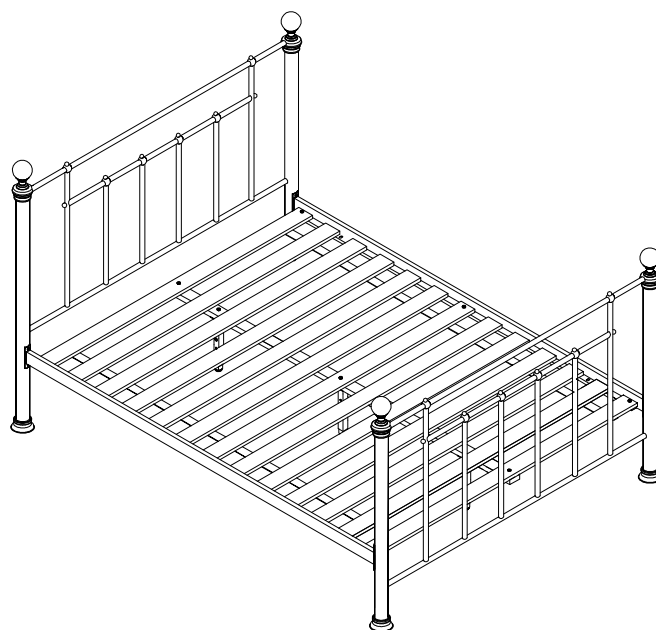

Minimum No. of people recommended to assemble this product:

2

Approx assembly time:

1/2 hours

### Before you Start, here are some helpful advices.







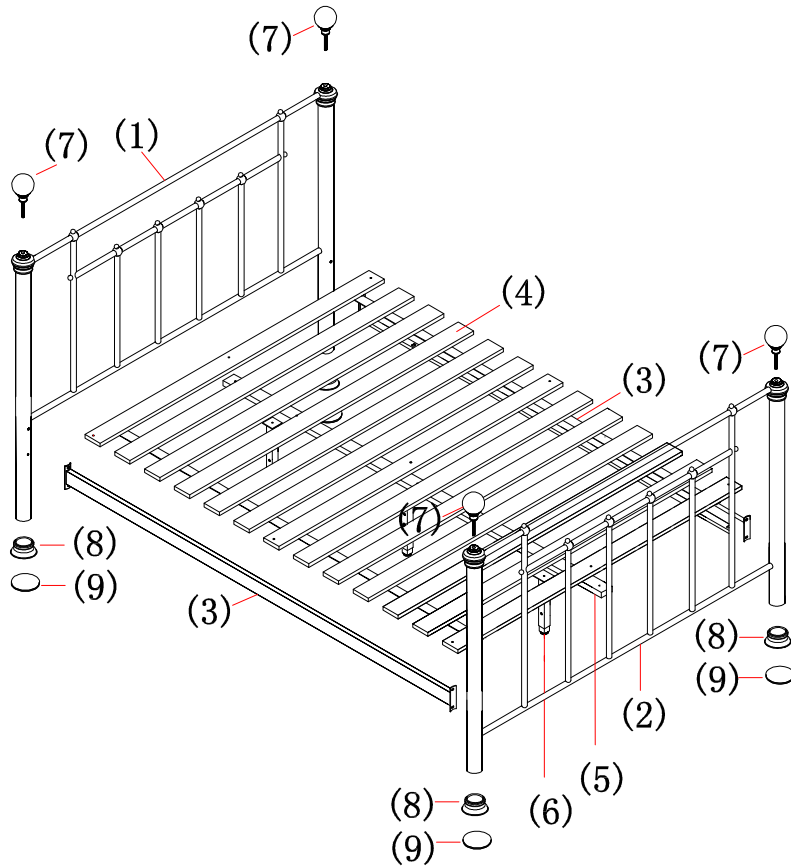

1. We suggest you spend a short time reading through this leaflet and then follow the simple step by step instructions.
2. If you follow the instructions carefully the end result should be worth the effort.
3. Do not discard any of the packaging until you have checked that you have all the parts and the pack of fittings.
4. Assemble this product on a carpet.
5. To ensure an easier assembly, we strongly advise that all fittings are only finger tightened during initial assembly. Only upon completion of the Assembly should all fixing points be fully tightened.
6. We recommend a periodic check on all fixing points to make sure they remain fully tightened.
7. Keep glue and fittings out of children's reach.

# PARTS

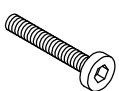
# Fittings

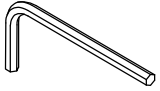

NO.	PART LIST	QTY
(1)	Headboard	1
(2)	Footboard	1
(3)	Side Rails	2
(4)	Solid slats	1
(5)	Center Rail	1
(6)	Supporting	3
(7)	Finials	4
(8)	Foot Slider	4
(9)	Foam Pads	4

<b>A</b>		M8 x 25mm x8pcs
<b>B</b>		M6 x 30mm x14pcs
<b>C</b>		M6 x 45mm x1pcs
<b>D</b>		M6 x8pcs
<b>E</b>		Metal Washer(M6) x15pcs
<b>F</b>		Plastic Washer x8pcs
<b>G</b>		4mm Allen key x2pcs
<b>H</b>		5mm Allen key x1pcs
<b>I</b>		Metal Washer(M8) x8pcs

# ASSEMBLY

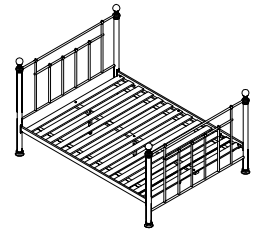

1. Attach foot slider (8) to headboard (1) and footboard (2) by using bolts (B) metal washer (E) and tightening with allen key (G).

2. Peel the rear tape from the foam pads (9) and stick them to the base of the foot slider (8).

## STEP 1

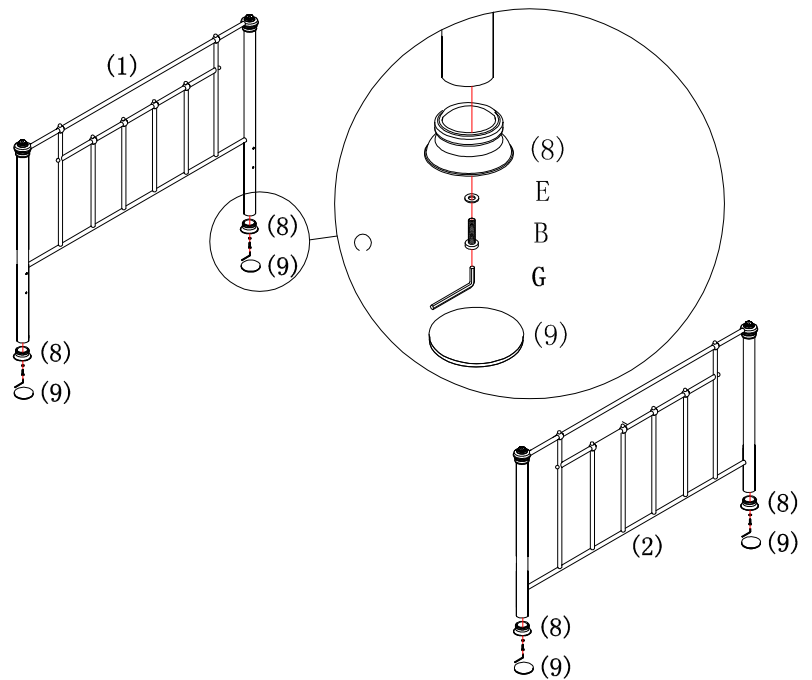

# ASSEMBLY

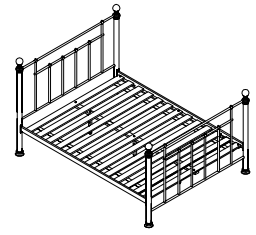

1. Use bolt (A)、washer (I) and plastic washer (F) to fix the side rail (3) onto headboard (1) and footboard (2) by using allen key (H).

## STEP 2

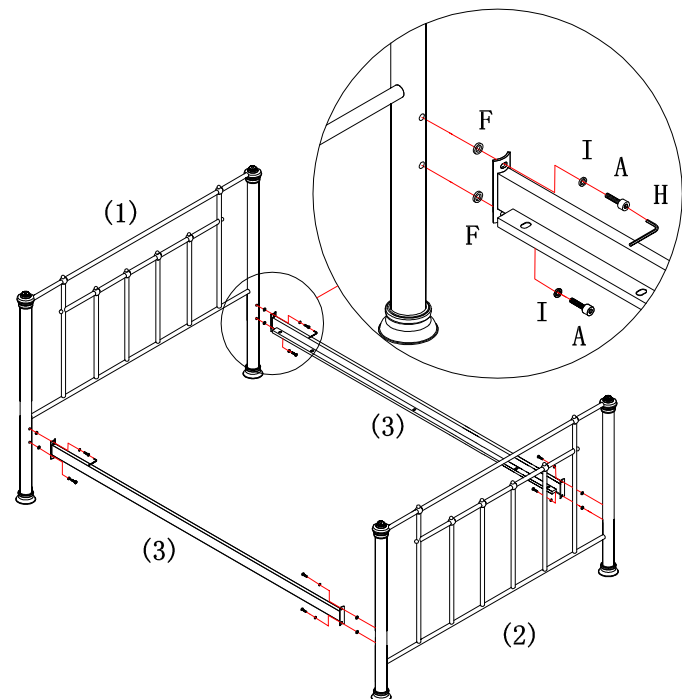

# ASSEMBLY

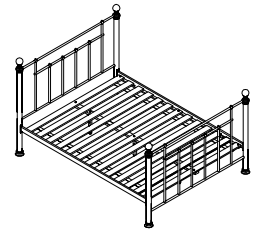

1. Attach finials (7) to headboard (1) and footboard (2) turning clockwise by hand to tighten.

## STEP 3

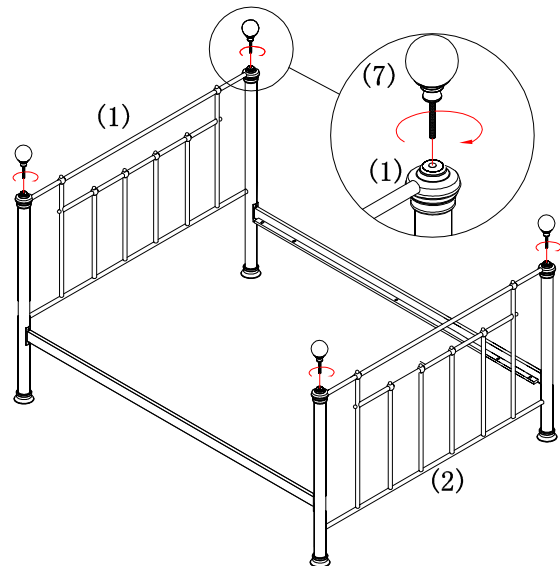

# ASSEMBLY

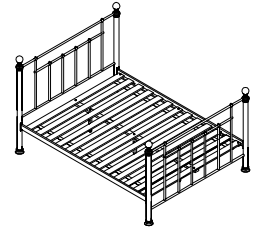

1. Put slats (4) onto bed side rails(3).

2. Assemble slats (4) onto side rails(3) by using bolt (B), washer (E), nut (D) and allen key (G).

## STEP 4

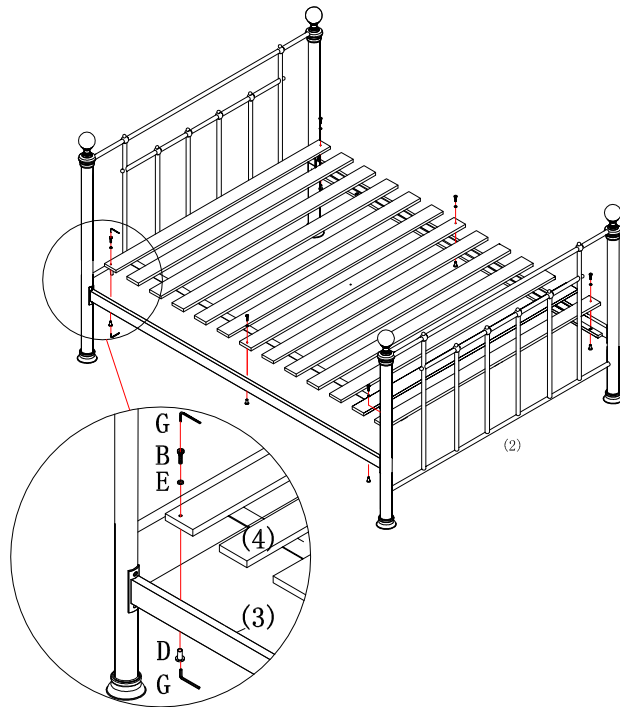

# ASSEMBLY

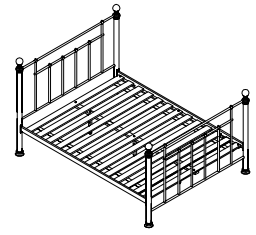

1. Assemble center rail (5) under slats, by using bolt (B), washer (E), nut (D) and tighten with allen key (G)

## STEP 5

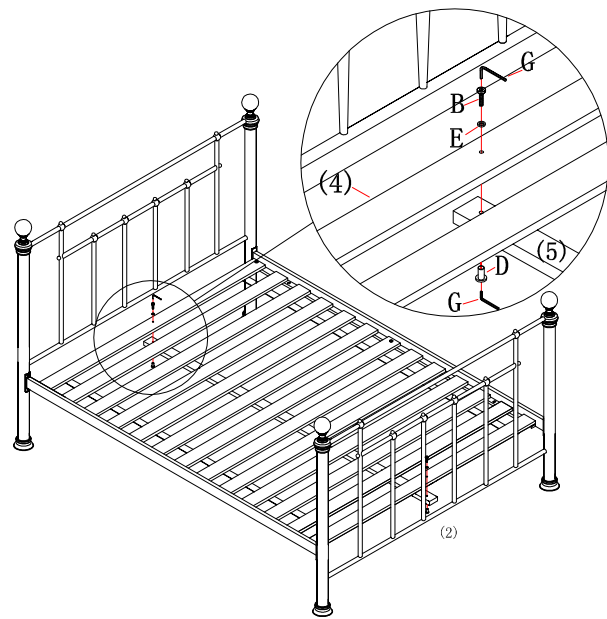

# ASSEMBLY

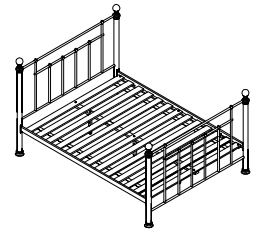

1. Assemble the center support leg (6) to center rail (5) by using Bolt (C), washer (E), tighten with allen key (G).

2. Assemble the support leg (6) at two ends by using bolt (B), washer (E) and tighten with allen key (G).

## STEP 6

