



CURVED OAK KING BED

ASSEMBLY INSTRUCTIONS

DO NOT OVER TIGHTEN SCREWS UNTIL COMPLETELY ASSEMBLED

WARNING/DISCLAIMER

FAILURE TO FOLLOW THE ASSEMBLY INSTRUCTIONS COULD CAUSE HARM AND VOID THE WARRANTY. IF YOU ARE UNSURE PLEASE CONTACT YOUR PLACE OF PURCHASE.

NEVER MOVE THE BED WITH THE MATTRESS OR OCCUPANTS IN PLACE. NEVER DRAG THE BED. USE CAUTION IF PLACING ITEMS UNDER THE BED, ENSURE THEY DO NOT MAKE CONTACT WITH THE CENTRE SUPPORT LEGS.

IF YOU DISASSEMBLE THE BED, YOU MUST REASSEMBLE AS PER THE INSTRUCTIONS.

SIDE RAILS MUST BE SETUP THE CORRECT WAY - DO NOT ASSEMBLE THE SIDE RAILS UPSIDE DOWN.



CENTRE RAIL AND SUPPORT LEGS ARE PROVIDED TO ADD MORE STABILITY TO THE BED ONCE THE MATTRESS IS IN PLACE. THE ADJUSTABLE FEET (LOCATED AT THE BOTTOM OF THE SUPPORT LEGS) ARE PROVIDED TO ALLOW FOR THE POSSIBILITY OF A SLIGHTLY UNEVEN FLOOR, THEY SHOULD NOT TOUCH THE FLOOR UNTIL THE MATTRESS AND OCCUPANTS ARE IN PLACE. FOLLOW THE INSTRUCTIONS STEP BY STEP.

AFFIX THE CENTRE RAIL SUPPORT LEGS, ENSURE THAT ALL FASTENING BOLTS ARE FULLY TIGHTENED. ENSURE THAT THE ADJUSTABLE FOOT IS TIGHTENED FULLY ALL THE WAY INSIDE THE WOOD LEG SUPPORT. THE BLACK FOOT SHOULD NOT TOUCH THE FLOOR AT THIS POINT.

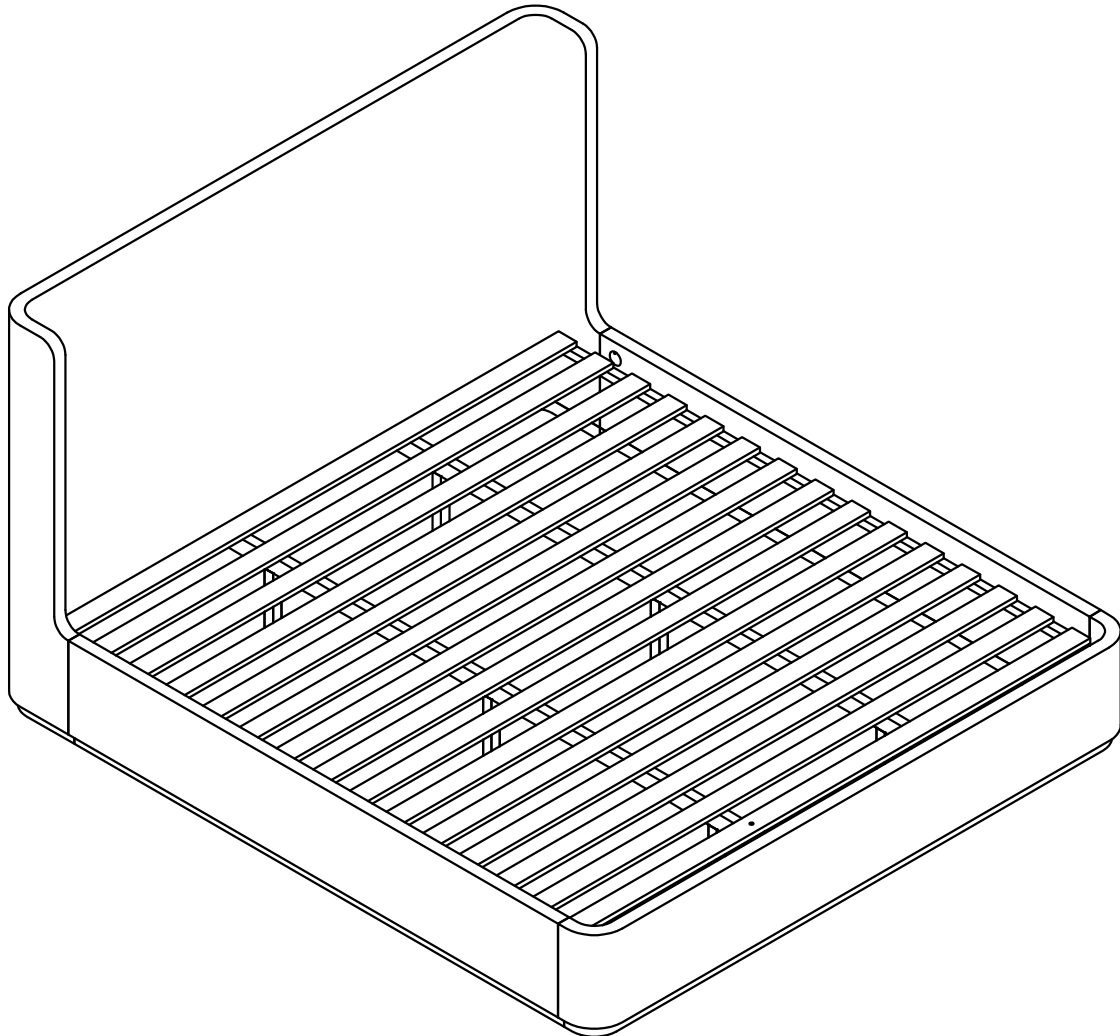



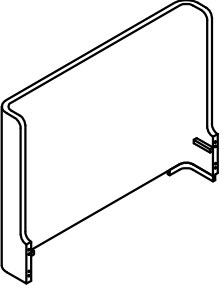
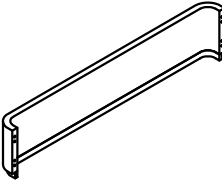
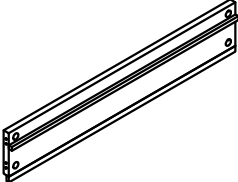
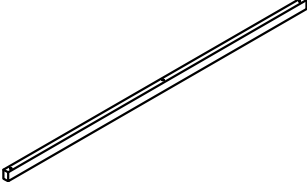
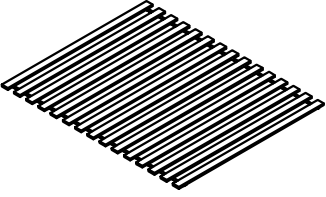



ONCE THE BED IS FULLY ASSEMBLED PLACE THE MATTRESS AND OCCUPANTS ON. CHECK EACH ADJUSTABLE FOOT ON THE BOTTOM OF THE SUPPORT LEGS. THEY SHOULD ALL BE TOUCHING THE FLOOR. IF THE SUPPORT LEG FOOT IS NOT MAKING CONTACT WITH THE FLOOR, THE ADJUSTABLE FOOT CAN BE WOUND OUT FOR A MINOR ADJUSTMENT UNTIL IT TOUCHES THE FLOOR. DO NOT UNWIND IT TO THE POINT WHERE IT IS LIFTING THE BED IN THE CENTRE. EXCESS WINDING CAN LEAD TO POTENTIAL DAMAGE AND MAKE THE FRAME UNSAFE.



PARTS LIST

<p>1</p>  <p>1</p>	<p>2</p>  <p>1</p>	<p>3</p>  <p>2</p>	<p>4</p>  <p>2</p>
<p>5</p>  <p>1</p>	<p>6</p>  <p>6</p>		

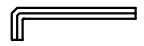
HARDWARE LIST

<p>A</p>  <p>8</p>	<p>B</p>  <p>M8×75mm</p> <p>8</p>	<p>C</p>  <p>Ø8 Spring washer</p> <p>8</p>	<p>D</p>  <p>M8 Nut</p> <p>8</p>	<p>E</p>  <p>Ø10×40mm</p> <p>8</p>	<p>F</p>  <p>Ø4×35mm</p> <p>8</p>
<p>G</p>  <p>M8×35mm Bolt</p> <p>6</p>	<p>H</p>  <p>5MM Allen Wrench</p> <p>1</p>	<p>I</p>  <p>Spanner</p> <p>1</p>			

STEP 1

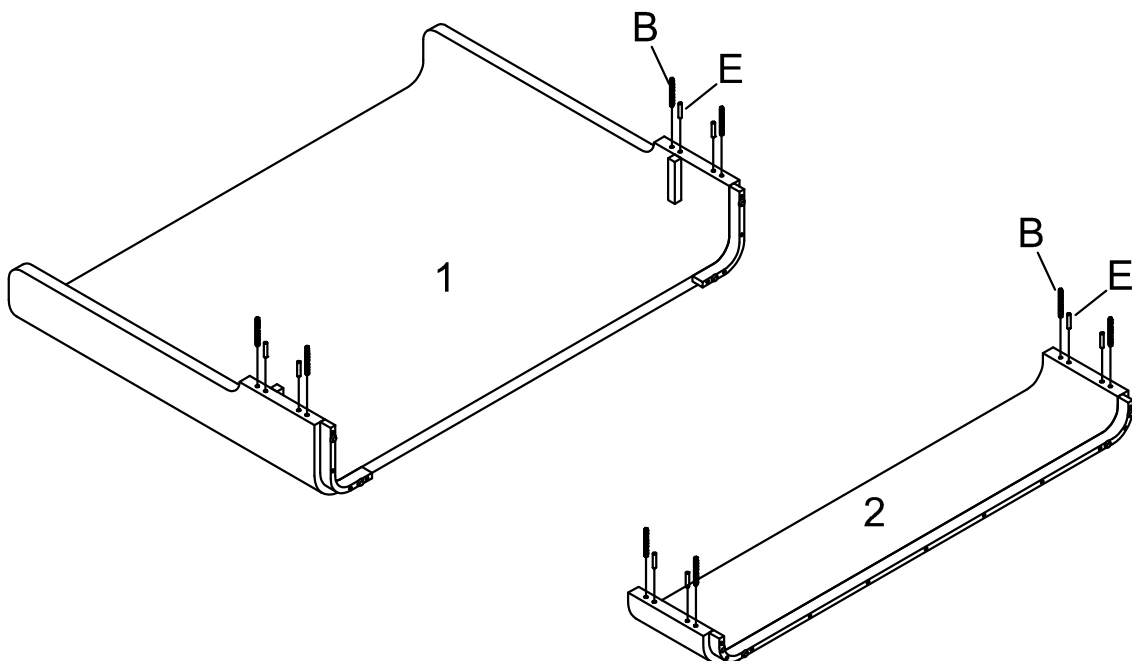

STEP 2

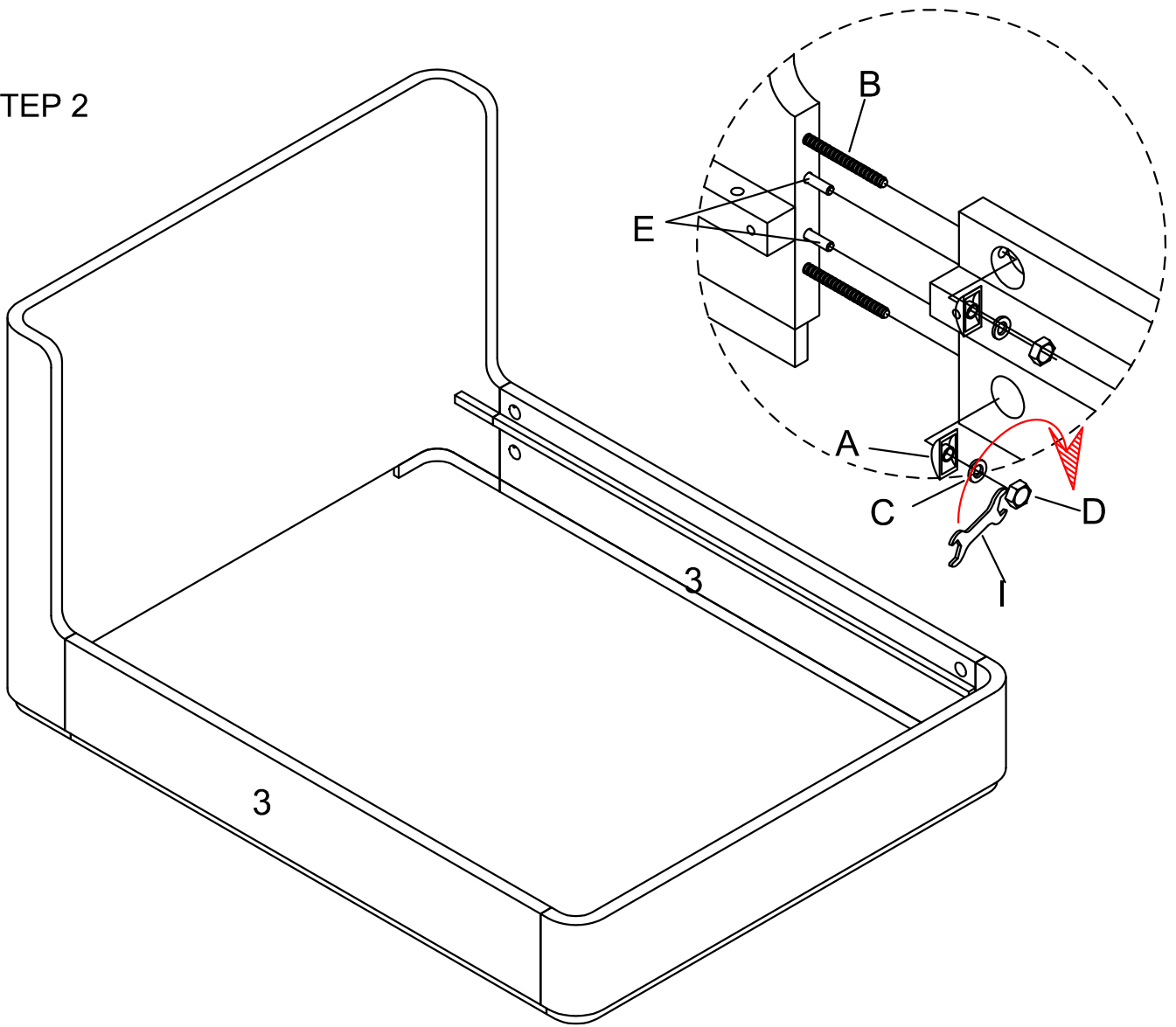

STEP 3

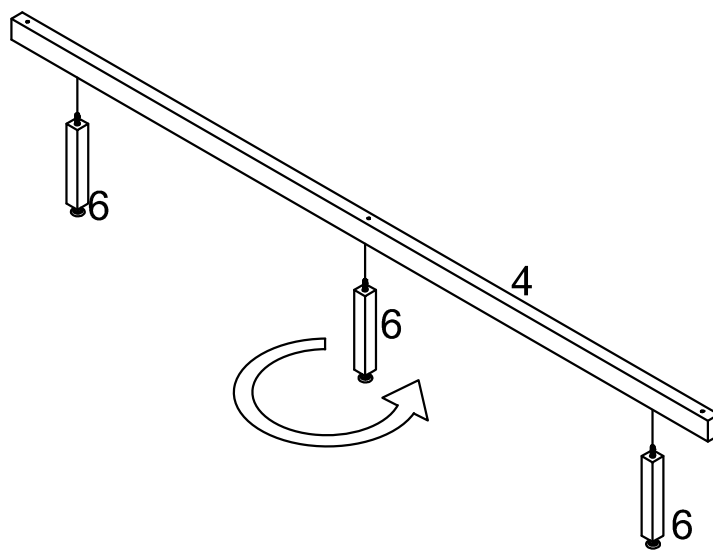

STEP 4

