

Copper bed

Assembly Instructions

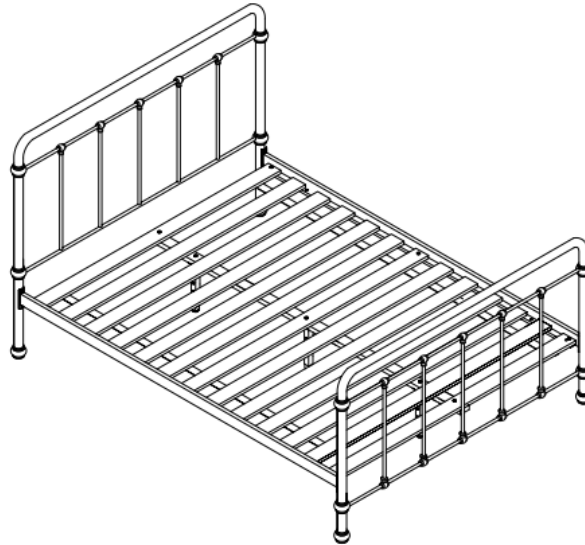

Minimum No. of people
recommended to assemble
this product:

2

Approx assembly time:

1/2
hours

Before you Start, here are some helpful advices.

1. We suggest you spend a short time reading through this leaflet and then follow the simple step by step instructions.
2. If you follow the instructions carefully the end result should be worth the effort.
3. Do not discard any of the packaging until you have checked that you have all the parts and the pack of fittings.
4. Assemble this product on a carpet.
5. To ensure an easier assembly, we strongly advise that all fittings are only finger tightened during initial assembly. Only upon completion of the. Assembly should all fixing points be fully tightened.
6. We recommend a periodic check on all fixing points to make sure they remain fully tightened.
7. Keep glue and fittings out of children's reach.

PARTS

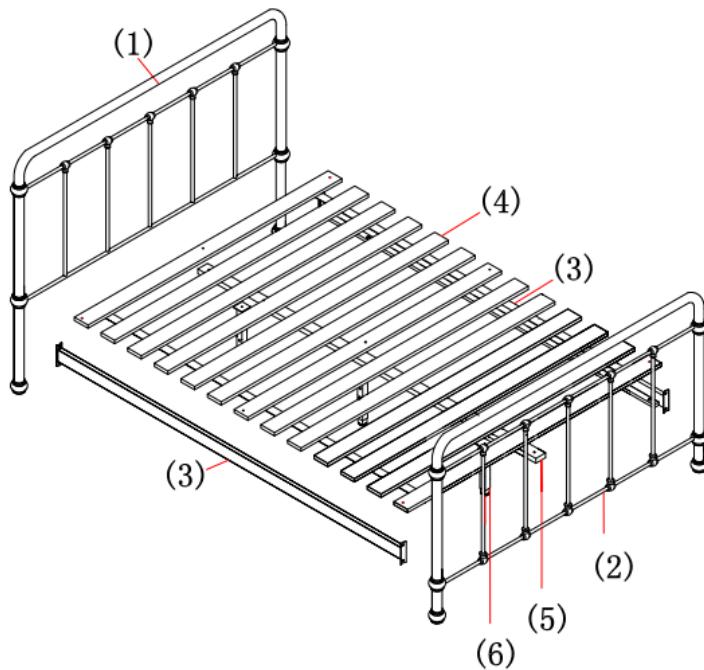

NO.	PART LIST	QTY
(1)	Headboard	1
(2)	Footboard	1
(3)	Side Rails	2
(4)	Solid slats	1
(5)	Center Rail	1
(6)	Supporting	3

Fittings

A

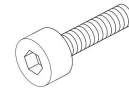

M8x25mmx8pcs

B



M6x30mmx10pcs

C

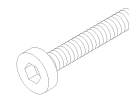

M6x45mmx1pcs

D



M6x8pcs

E



Metal Washer(M6) x11pcs

F



Plastic Washer x 8pcs

G



4 Allen key x 2pcs

H



5 Allen key x 1pcs

I



Metal Washer(M8) x8 pcs

ASSEMBLY

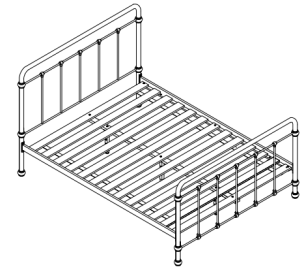

1. Use bolt A, washer I and plastic washer F to fix the side rail (3) onto headboard (1) and footboard (2) by using Allen Key (H).

STEP1

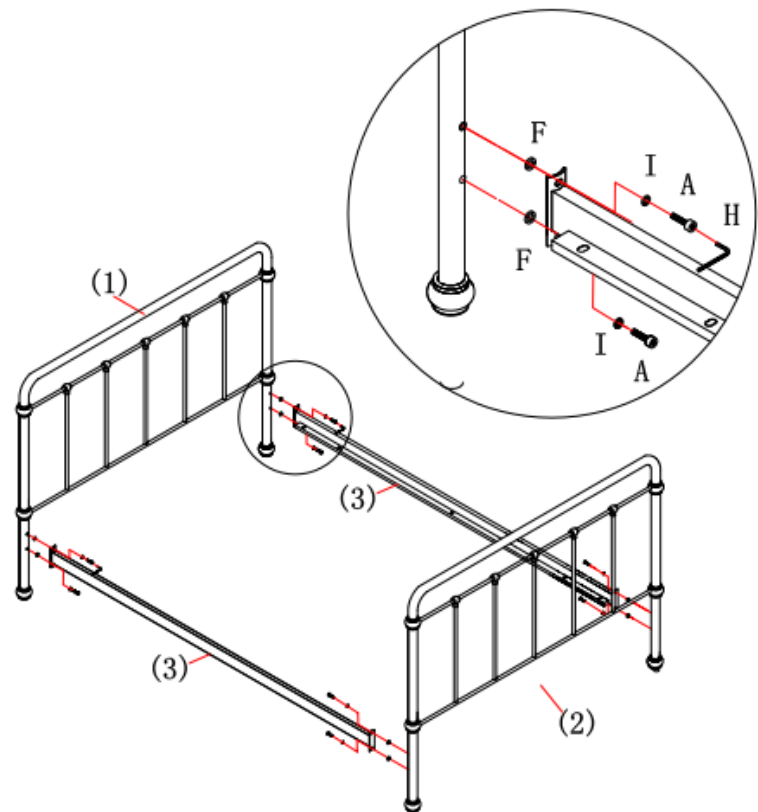

ASSEMBLY

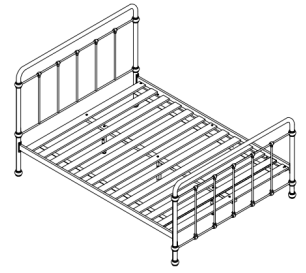

STEP

1. Put Slats (4) onto bed side rails(3).
2. Assemble Slats (4) onto Side Rails(3) by using Bolt (B), washer (E), nut (D) and Allen Key (G)。

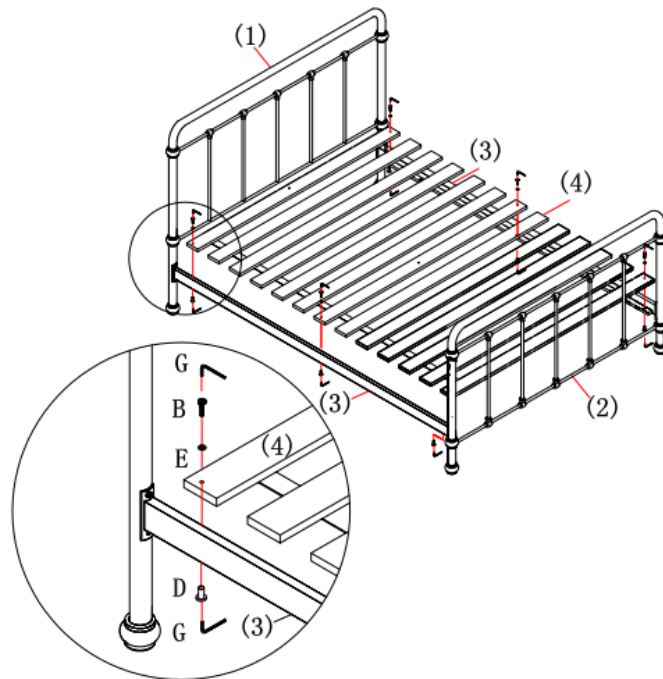

ASSEMBLY

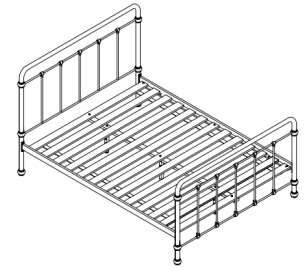

1. Assemble Center Rail (5) under slats, by using bolt (B), washer (E), nut (D) and tighten with Allen Key (G).

STEP

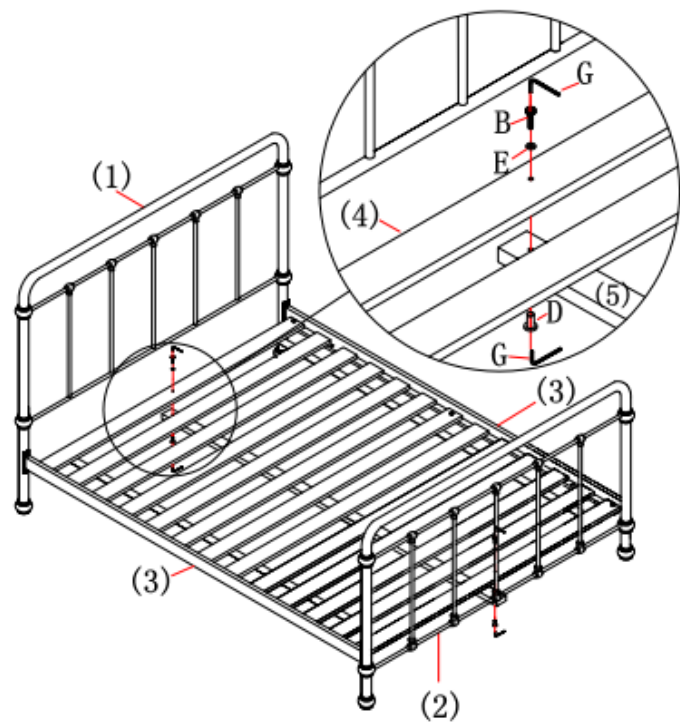

ASSEMBLY

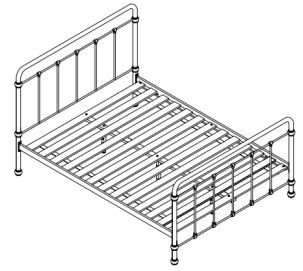

1. Assemble the center support leg(6) to center rail(5) by using Bolt (C), washer (E), tighten with Allen Key (G).
2. Assemble the support leg (6) at two ends by using Bolt(B), washer (E) and tighten with Allen Key (G).

STEP4

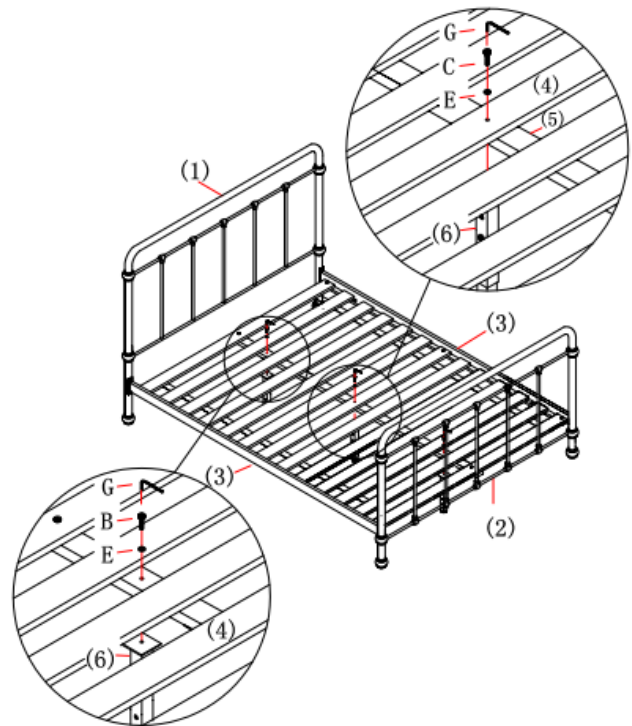

Filename: Madrid AI.docx
Directory: /Users/davebishop/Library/Containers/com.microsoft.Word/Data/Documents
Template: /Users/davebishop/Library/Group Containers/UBF8T346G9.Office/UserContent.localized/Templates.localized/Normal.dotm
Title: 没
Subject:
Author: lenovo
Keywords:
Comments:
Creation Date: 03/06/2021 06:52:00
Change Number: 2
Last Saved On: 03/06/2021 06:52:00
Last Saved By: Dave Bishop
Total Editing Time: 0 Minutes
Last Printed On: 03/06/2021 06:52:00
As of Last Complete Printing
Number of Pages: 6
Number of Words: 27
Number of Characters: 380 (approx.)