



AVIATION

PRODUCT INSTRUCTIONS
Model Number: 30M-TJ



Bogert Aviation Tribal Jack Instruction Manual


Introduction:

This is a NEW VERSION of the Tribal Jack which uses a different way of attaching the jack pad assembly to the jack ram. In this version, the jack pad installs over the extension screw of the jack which has been fitted with the ESC-6 Extension Screw Collar. The net result will be additional stroke. The operation of the jack and the jacks performance are essentially the same.


Originally designed for the Piper Tribe of aircraft, Bogert Aviation's Tribal Jack has proven itself to be a great multipurpose shop tool for many aircraft models having oleo strut landing gear. The Tribal Jack is very useful for annual inspections as well as changing a tire or packing wheel bearings. Fixing a flat is easy with the 'new' lower clearance lifting pad. It can be used on main gear, nose gear and the tail wheel.

Use the Tribal Jack with Landing Gear Support Stand (PN17M-LGSS) for added safety. Please watch our video to see it in action. The Tribal Jack starts as low as 2 inches and can lift as high as 12 inches. Lift stroke is 4.5 inches. The jack has an extended base plate eliminating the risk of tipping the jack over.





The warnings, precautions, and instructions discussed in this manual cannot cover all possible conditions and situations that may occur. The operator must understand that common sense and caution are factors, which cannot be built into this product, but must be supplied by the operator.

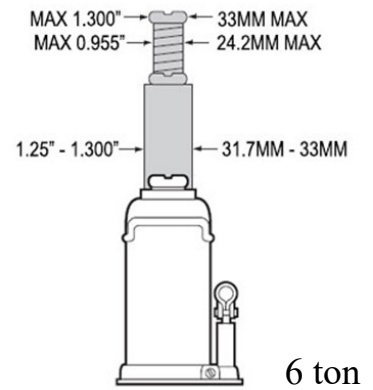


Cautions:

- Do not exceed 2500 lbs.
- Support the axle anytime the wheel is removed with a suitable axle stand or blocking. (Bogert Aviation 17M-LGSS, Landing Gear Safety Stand)
- Do not allow anyone to climb on or get into the aircraft while supported by a jack.
- “WARNING” Study, understand and follow all instructions before operating this device.
- Lifting device only.
- Intended use is for lifting part of a total aircraft, only one wheel or axle at a time.
- Immediately after lifting, support aircraft with appropriate means.
- Do not exceed rated capacity. Use only on hard, level surfaces capable of sustaining rated capacity loads.
- Lift only on those areas of the vehicle as specified by the vehicle manufacturer.
- Ensure that the lift point is properly centered on the jack saddle.

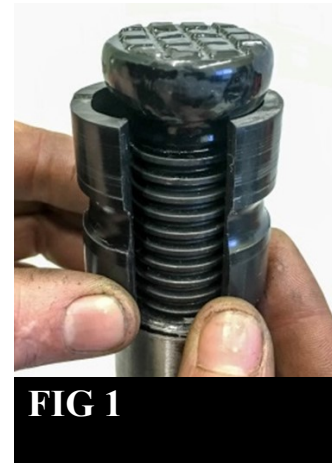
Always wear safety glasses when using this equipment.

Limitations: The EXTENTION SCREW COLLARS (ESC) are designed to work with 6 ton rated jacks that fall within the minimum and maximum size as shown.

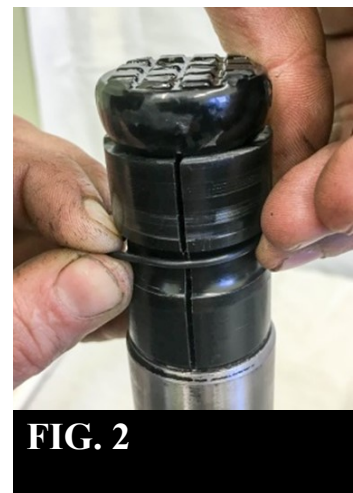


Installation:

1. Remove the O-Ring that holds the ESC together.
2. Extend the screw of your jack until the ESC will fit around the screw and close together. **FIG 1**



3. Install the O-Ring back over the ESC so that the O-ring fits into the groove. **FIG. 2**



5. Turn the screw in until it bottoms snugly against ESC. **FIG.3**



The warnings, precautions, and instructions discussed in this manual cannot cover all possible conditions and situations that may occur. The operator must understand that common sense and caution are factors, which cannot be built into this product, but must be supplied by the operator.

Operation:

1. Open the jacks RELEASE VALVE by turning the screw counter-clockwise about $\frac{1}{2}$ to 1 turn using the jack handle. **FIG. 4**



FIG 4

2. Fully compress the jack ram. **FIG. 5**



FIG. 5

3. Place the yellow Tribal Jack Pad over the extended jack saddle and Extension Screw Collar. It should face the extended base of the jack. **FIG. 6**



FIG. 6

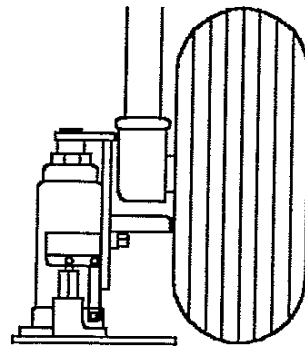
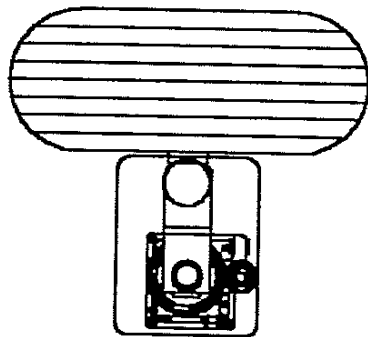
4. Adjust the LIFT SHELF height.

Note: To provide the maximum available lift and greatest jack strength, always place the shelf in the highest possible position before jacking. **FIG 6**

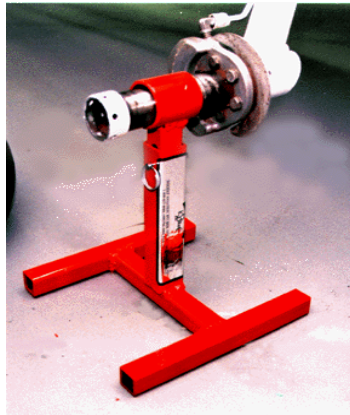


FIG. 6

5. Tighten the shelf nuts with a 9/16 inch socket wrench.
6. Tighten the jack RELEASE VALVE by turning it clockwise with the jack handle.
7. **PLACING THE JACK:** Place the jack shelf directly under the oleo strut and in-line with the axle as shown in illustration



8. **TO RAISE:** Use the jack handle to operate the jacks pump and raise the strut until the tire is off the ground. NOTE: Do not over extend the jack.
9. Make sure the jack is stable before removing the wheel and tire.
10. Support the axle with an axle stand or at the very least blocks of wood when the wheel is removed. The Bogert Aviation PN: **17M-LGSS** Landing Gear Support Stand works well.



11. **TO LOWER:** Slowly turn the RELEASE VALVE counter clockwise with the jack handle and slowly lower the jack. When the tire is resting on the ground and the axle is free of the jack, remove the jack,

For more information, see our You-Tube Videos at
<https://www.youtube.com/user/BogertAviation>
Or search for Bogert Aviation.

Bogert Aviation Inc.
3606 N. Swallow Ave. Ste 100
Pasco, WA 99301 USA
(509) 736-1513 Phone
(800) 627-8088 Toll Free
(509) 272-0280 Fax
www.bogertaviation.com
info@bogert-av.com

