

Instruction Manual

220L

Compost Tumbler



Assembly Instructions

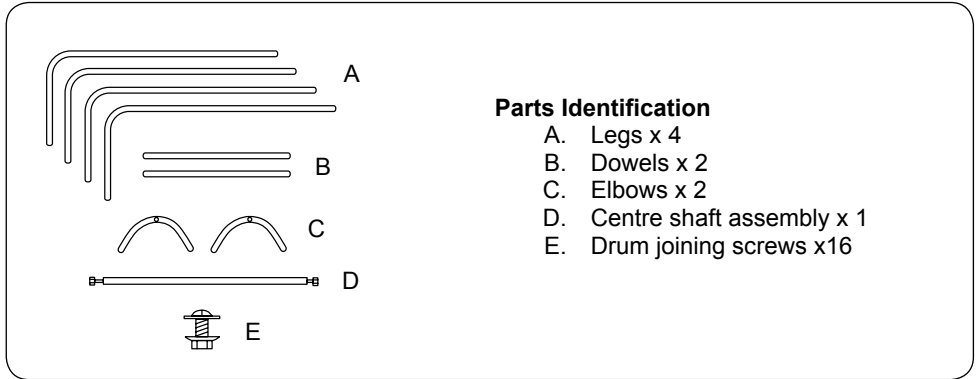

- 1** Remove nuts from Centre Shaft assembly (D) and fit elbows (C) with indent facing out. Refit nuts and tighten each end using two spanners turning in opposite directions until nuts lock.

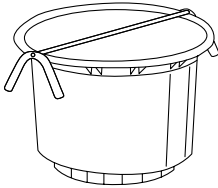
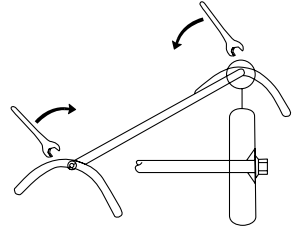

- 2** Locate Centre Shaft assembly in bearing grooves of one drum half.

- 3** Assemble drum by placing second half on top of first half making sure to locate bearing grooves. Join drum halves together using drum joining assembly (E). Fit 16 screws with washers in holes before adding and tightening nuts.

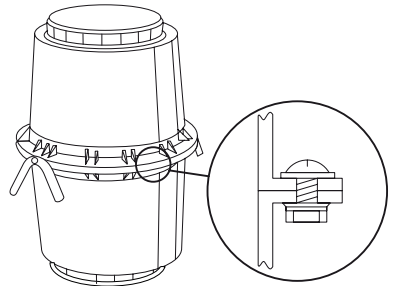

- 4** Assemble both sets of legs (A) together by fitting dowel (B) into short part of legs and pressing together and repeat for second set.

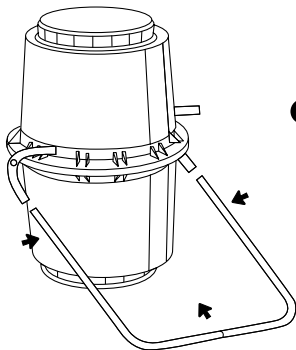
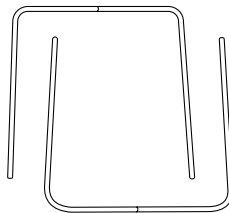

- 5** Fit one leg set to elbows by pressing "U" shape together sufficiently to allow entry to elbows.

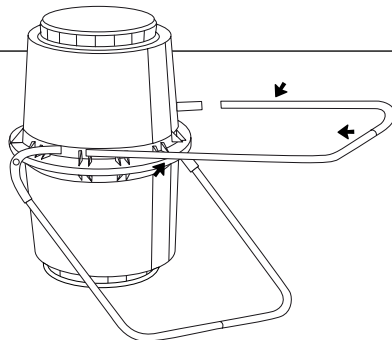

- 6** Fit second leg set to elbows using the same method.

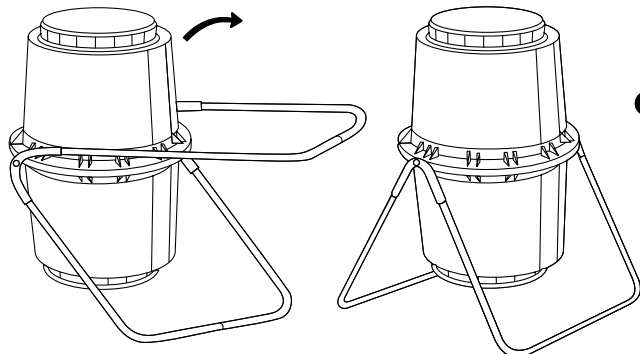

- 7** Lift Tumbleweed 220L Compost Tumbler onto the stand.

Five easy steps to compost tumbling

1. Choose a sunny position
2. Add small pieces of organic waste
3. Aim for 50% garden waste such as grass clippings and leaves* (carbon) to 50% kitchen food scraps (nitrogen)
4. For best results add a handful of soil or compost
5. Tumble every two days

**Grass clippings and leaves can be replaced with shredded paper and cardboard to make up the 50% carbon*

Why make compost?

Making compost is the perfect way to recycle organic garden and kitchen waste into a highly nutritious soil conditioner. Its fun to do, and it doesn't cost the earth.

The compost you make will help retain water in your garden's soil and efficiently deliver valuable nutrients to the roots of your plants.

How is compost made?

Compost is made when micro-organisms feed on plant matter and break it down into smaller and smaller pieces. When the waste is fully decomposed it forms humus - or compost – a dark, soil-like material with a pleasant earthy smell.

Your 220L Compost Tumbler has been designed to provide micro-organisms with the ideal environment they need to compost your waste quickly, and with minimal effort from you!

While natural decomposition of organic waste takes a long time, composting with a Tumbleweed 220L Compost Tumbler can take just four weeks. As it creates the perfect environment and provides the air, water, food and mixing that micro-organisms need to rapidly multiply and quickly break down organic waste.

Your 220L Compost Tumbler will generate heat. This is important because some micro-organisms only work when the temperature is elevated. The more micro-organisms you have working, the better your compost will be.

Choose the best spot for your 220L Compost Tumbler

Find a sunny spot – heat absorbed from the sun will help activate more of the micro-organisms.

Make it accessible – You'll need to turn your Tumbleweed 220L Compost Tumbler regularly. So place it where it is easy to use.

Place it on any surface – the ground does not need to be perfectly flat, it can even go on a hard surface such as concrete or pavers.

Only add organics

Micro-organisms eat organic 'food'. That means you should only put materials into your 220L Compost Tumbler that were once alive. Lawn clippings, leaves, flowers, small green prunings, vegetable scraps, eggshells and general garden waste are ideal, you can even use shredded newspaper and cardboard.

The smaller the pieces of waste, the faster it will decompose, so it's a great idea to run your mower over garden waste like leaves and dead flowers before you throw them into your composter.

Lawn clippings, which are small and quick to decompose, can be used to make mulch without any other ingredients. However, vegetable scraps, which contain a lot of water, should be mixed with drier ingredients. That's because if the water content becomes too high in your compost bin there may be insufficient air for the micro-organisms to work effectively. For the best composting results, aim for 50% garden waste such as grass clippings and leaves* (carbon) to 50% kitchen food scraps (nitrogen). *

**Grass clippings and leaves can be replaced with shredded paper and cardboard to make up the 50% carbon*

What not to add to your 220L Compost Tumbler

Twigs and large woody prunings are slow to decompose in any composting system. Meat, fish, fat, dog droppings and dairy products also decompose slowly and may cause odours.

Filling and tumbling your 220L Compost Tumbler

You don't need to generate a large amount of organic waste or completely fill the 220L Compost Tumbler before you begin making compost.

However, whether you choose to fill the tumbler in one go or add to it slowly, you'll need to tumble it several times every two days. This will aerate the compost and encourage the micro-organisms to work efficiently.

Over time, the contents of your 220L Compost Tumbler will reduce as it decomposes so that a full tumbler of organic waste will reduce to about 25% of its volume as compost.

Your compost will be ready in approximately four to six weeks from the time you last 'fed' it.

Tumbling is easy

Tumbling your Compost Tumbler is easy. Simply stand at its side and place one hand at each end of the tumbler. Tumble by pushing down on one hand and lifting it with the other, as shown in the diagram.

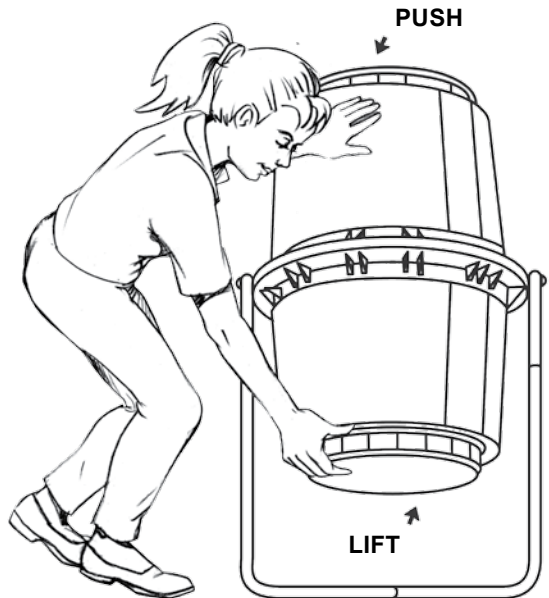

How to use your compost

Use it as a mulch

Spread the mulch over the surface of your garden bed to a depth of about 5cm or more. This will prevent moisture loss and attract worms that will further enrich your soil.

Use it as compost

If your soil is predominantly clay, sand or generally in poor condition, dig the compost in to improve its quality and attract worms.

Trouble shooting

Problems usually occur when the micro-organisms that cause decomposition do not have the right working environment. Here are some common reasons why

The compost is wet

Your compost should have the moisture content of a well squeezed sponge. If you've added too many vegetable scraps, which are high in water, your compost may be too wet and the micro-organisms may not be getting enough air. Aim for 50% garden waste (carbon) and 50% kitchen Food scraps (nitrogen).

To absorb excess moisture try adding ingredients such as torn scraps of newspaper or dry leaves, along with a liberal amount of Tumbleweed Worm Farm and Compost Conditioner and tumble the 220L Compost Tumbler to mix contents through. If this does not rectify the problem, you'll need to empty the bin and start again.

The contents in my bin are very hot

This is good news and a sign that the micro-organisms are doing their work. It will eventually cool down and produce compost.

Find out more

For more information on the Tumbleweed 220L Compost Tumbler, as well as valuable advice on recycling organic waste, worm farming and composting, please visit: www.tumbleweed.eu.com



**European Agent
Diggers Garden Products**

**Gardi Industrial Services Ltd, 9 Kennel Terrace, Brixworth,
Northampton, NN6 9DL. England. Tel:+44 (0) 1604 882442
email: enquiries@gardi.co.uk**

The Tumbleweed 220L Compost Tumbler is protected by various forms of intellectual property.

©TUMBLEWEED 2010