

GRATING
MANUFACTURED
IN 3mm MILD STEEL -
HOT DIP GALVANISED
FINISH

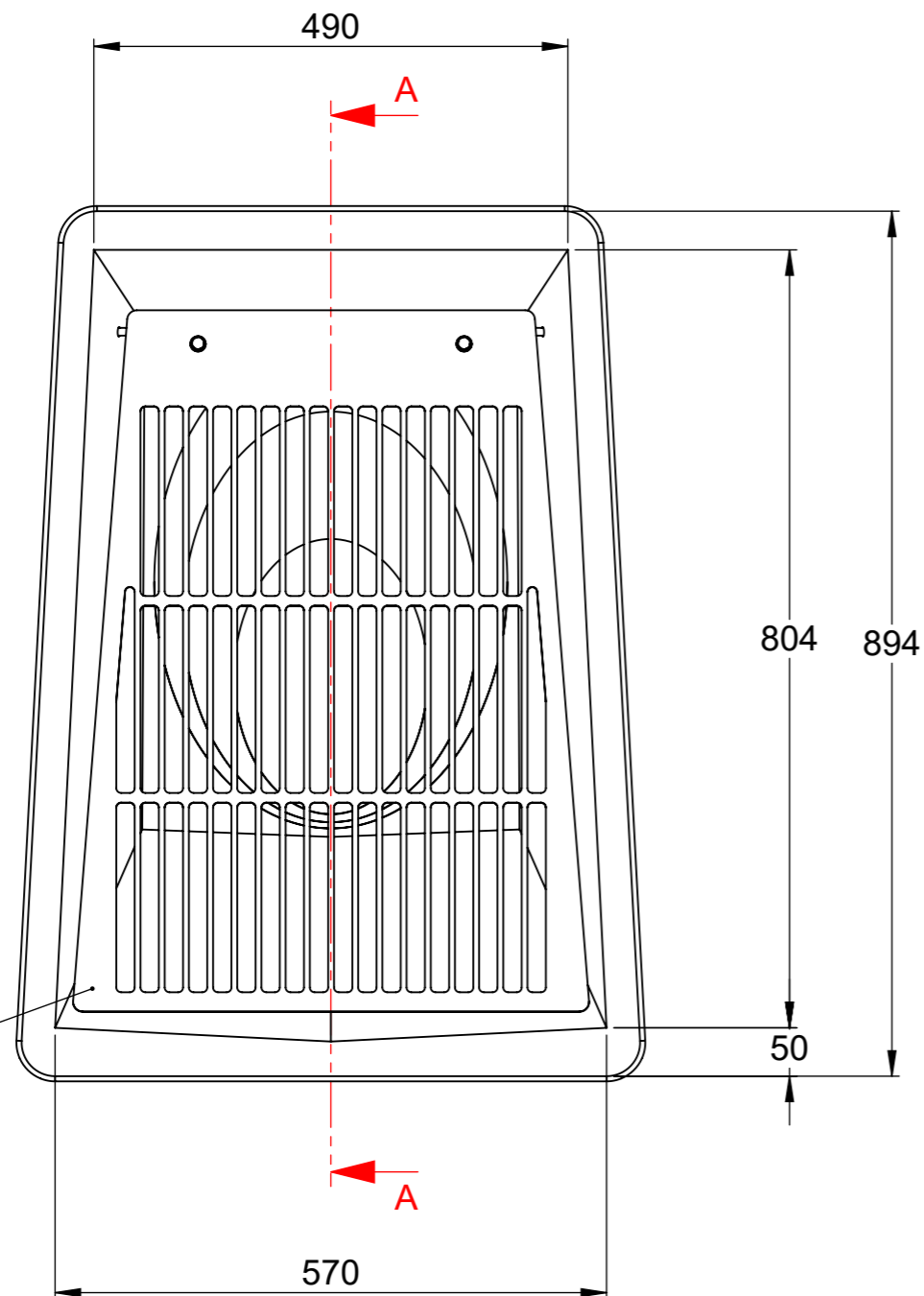

DO NOT SCALE DRAWING

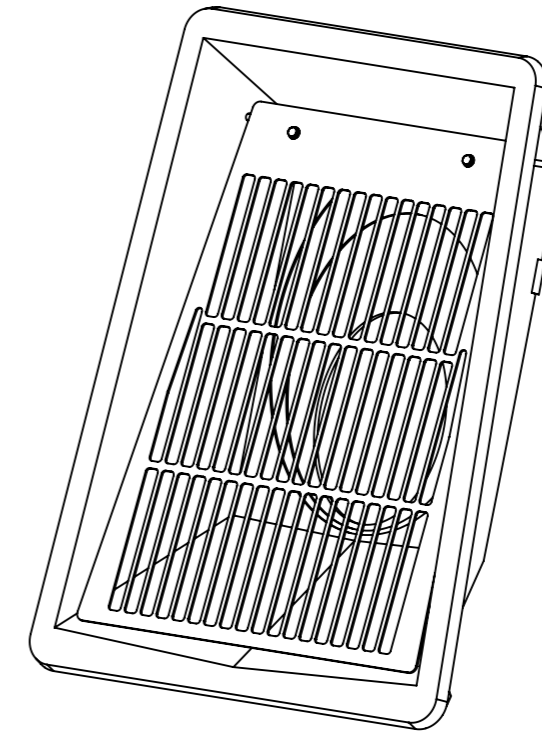

SECTION A-A

NOTES:
 * All dimensions in mm U.O.S
 * All measurements ± 1mm

Headwall Installation
 Dig out sufficiently to allow headwall flanges to finish flush with the batter. Take outfall pipe (minimum length 1.5m rigid impervious pipe) and slide it through headwall so it protrudes approximately 50mm. Make a good connection with the land drain and seal by returning approximately 150mm of soil into trench and consolidating. Unravel the string and draw the anchor back along the trench as the rest of the backfilling is completed.

Material

- Characteristic compressive strength of Glass Reinforced Concrete = 60N/mm²
- Characteristic flexural strength of Glass Reinforced Concrete = 6N/mm²
- Free water Cement ratio: <0.55
- Glass fibres - 63kg/m³
- Minimum Cement content: 900kg/m³
- Specification: XA2, DS2, DC2

DRAWING TITLE / PROJECT:

**GRC LARGE GENERAL
PURPOSE HEADWALL +
GRATING**

CLIENT:	N/A	
SCALE:	NTS	DRAWING DATE: 17/03/2021
HEADWALL WEIGHT:	24kg	GRATING WEIGHT: 4kg
TOTAL WEIGHT:	28kg	
DRAWN BY:	DH	CHECKED BY: JP
DRAWING No:		

Large General Purpose & Grating - JKH