

JGTIA – BASE MODEL WITH 500ER EXTENSION RISER FITTED

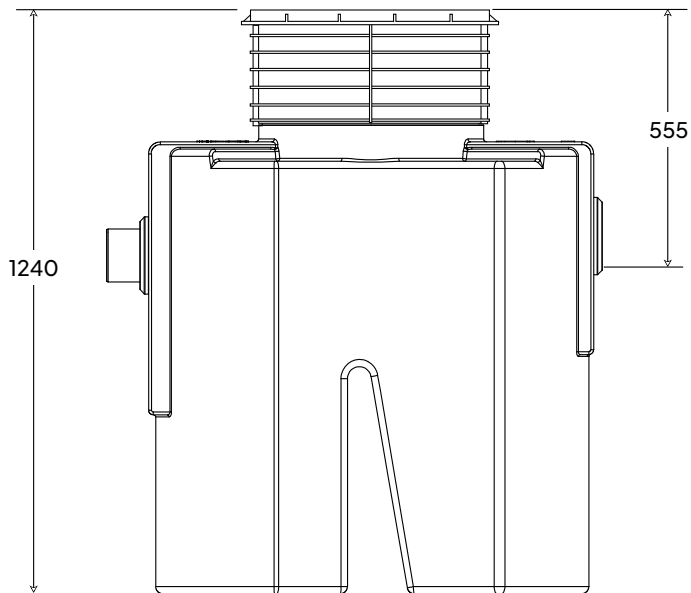

EXTENSION RISER

PRODUCT CODE: **500ER**

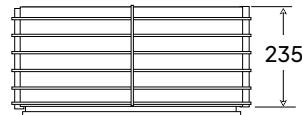

Working capacity	Sludge capacity	Height H	Length L	Inlet invert A	Outlet invert B	Standard pipework	Max. Width W	Access Ø E	Approx. Weight
Litres	Litres	mm	mm	mm	mm	mm		mm	kg
340	100	1005	940	320	355	110	620	475	25



PROPRIETARY & CONFIDENTIAL
THE INFORMATION CONTAINED IN THIS DRAWING IS THE SOLE PROPERTY OF TURTLE ENVIRO AND ANY REPRODUCTION IN PART OR AS A WHOLE WITHOUT THE WRITTEN PERMISSION OF TURTLE ENVIRO IS PROHIBITED.



DRAWN BY DVA	CONTRACT		
DRAWN DATE 12/5/2023	PRODUCT DESCRIPTION JUMBO FAT OIL & GREASE TRAP		
APPROVED BY D.A	PRODUCT/CODE: JGTIA		
APPROVED DATE 12/5/2023	SCALE:	SHEET/SIZE	A3 REV: 1