

THIS DOCUMENT IS SUPPLIED IN STRICT CONFIDENCE AND MUST NOT BE LENT, REPRODUCED OR DISCLOSED TO ANY THIRD PARTY WITHOUT THE WRITTEN CONSENT OF GRAF UK LTD

**DO NOT SCALE - IF IN DOUBT ASK**

NOTES:-

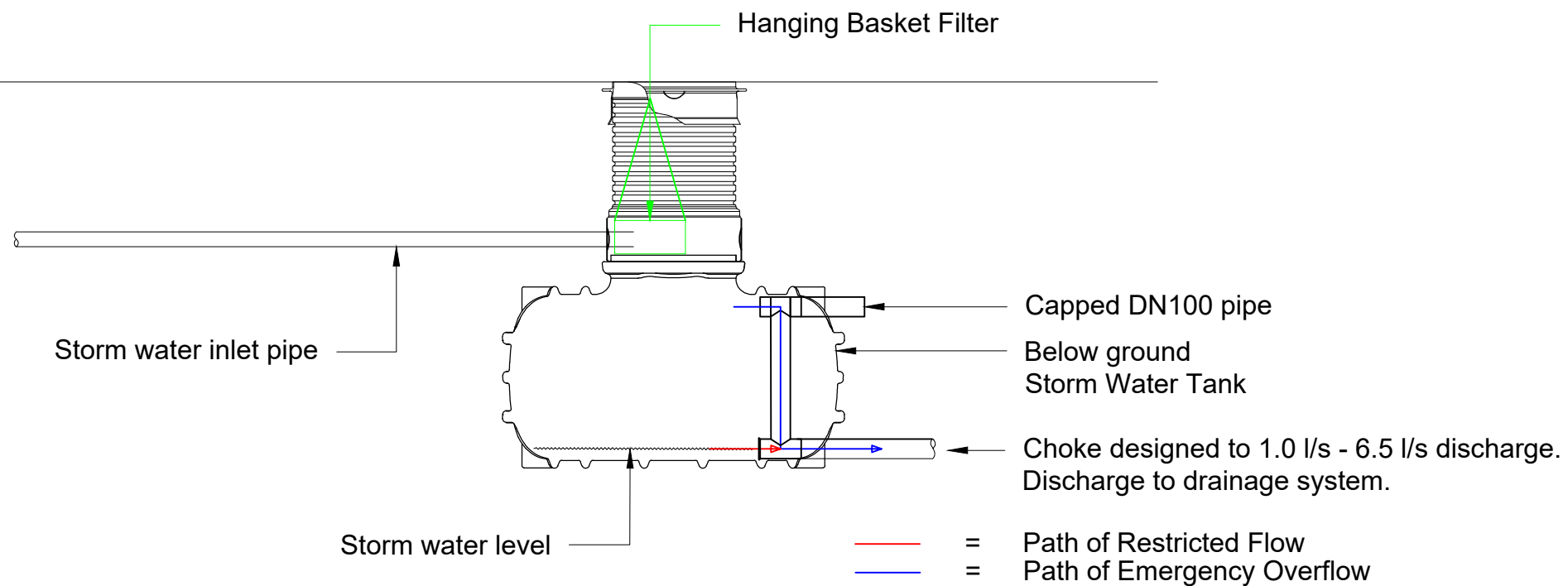
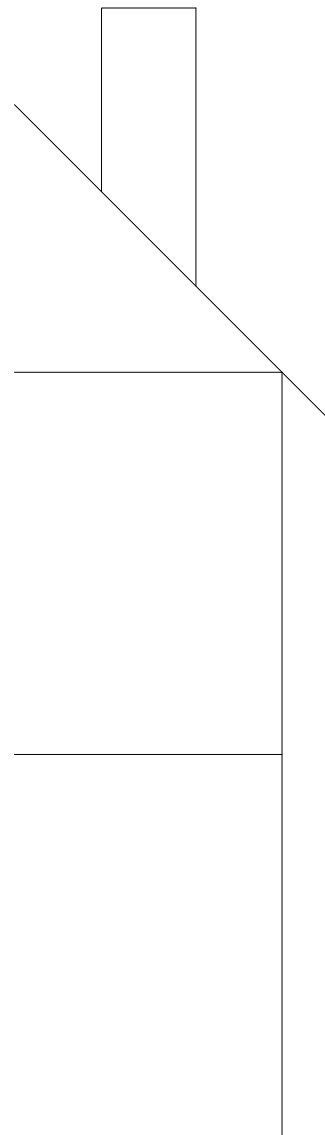
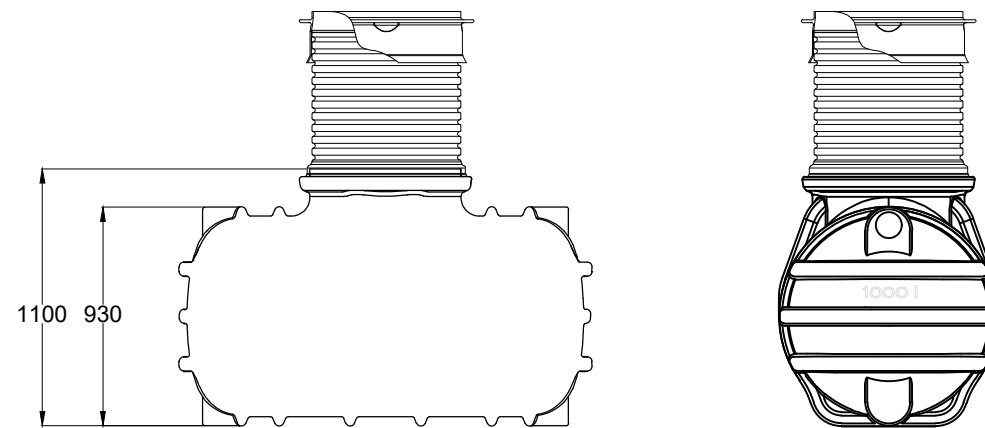
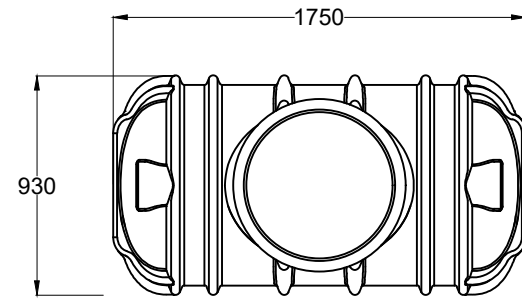

P0	FOR GUIDANCE	DS	25.01.22
REV.	DESCRIPTION	BY	DATE

**GRAF** GRAF UK Limited  
 Graf UK Limited | Regen House | Beaumont Road | Banbury | OX16 1RH  
 T: 01608 661500 F: 01295 211333  
 E: info@grafuk.co.uk www.grafuk.co.uk

DRAWN :	DS	DATE :	25.01.22
CHECKED :	MC	SCALE :	NTS@A3

PROJECT  
**Detention System**

DESCRIPTION

DRAWING No.	REV.
1000 litre Underground Tank	P0