

## PINK WATER SOFTENERS

Ultra-compact dimensions and Clack® DV valve make these softeners both space-saving and reliable. The compact design of the smallest model is combined with high flow and softening capacity due to the unique 10×13 mineral tank size, it fits easily under the kitchen sink.

### KEY FEATURES:

- Ultra-compact dimensions
- Reliable US-made Clack® DV with mixing valve
- Up-flow proportional regeneration for smart consumption
- Effective salt consumption: 80 grams per liter of resin or less
- Water-saving: uses up to 100 liters for regeneration

### COMPONENTS:

- Pre-adjusted US-made Clack® DV with mixing valve
- Cabinet enclosure
- Pressure tank
- Brine well with safety float valve



**LITTLE  
EFFICIENT  
SPACE-SAVING  
SOFTENER**

### DIMENSIONS:

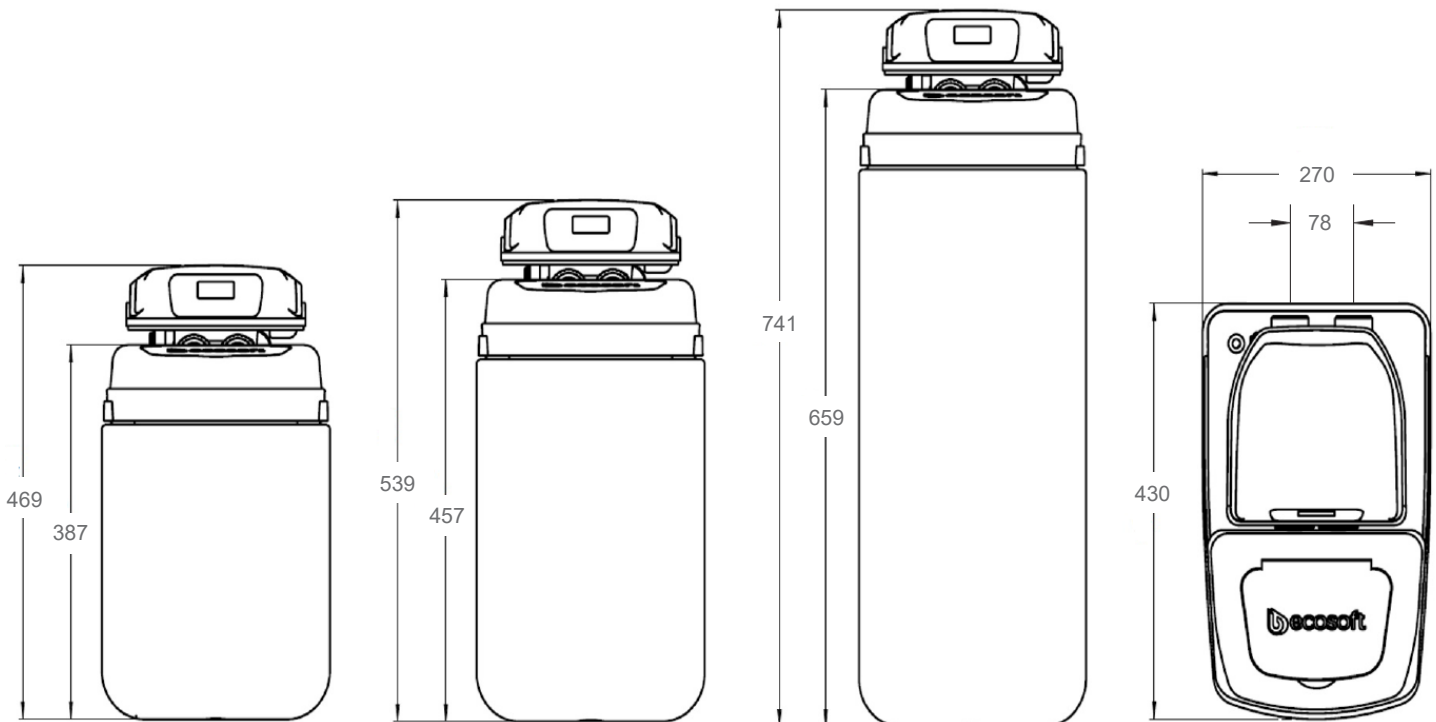

### ECOSOFT PINK COMPACT WATER SOFTENERS (ECOLITE)

Code	Description	Media volume, L.
FU1013CABDVUP	Ecosoft Pink 10 compact water softener	10
FU1016CABDVUP	Ecosoft Pink 15 compact water softener	15
FU1024CABDVUP	Ecosoft Pink 20 compact water softener	20

**TECHNICAL SPECIFICATION:**

Parameter	FU1013CABDVUP	FU1016CABDVUP	FU1024CABDVUP
Operating flow rate, m <sup>3</sup> /h	1.2	1.5	1.8
Quantity of media, L	10	15	20
Volume capacity, m <sup>3</sup> @250 mg/L CaCO <sub>3</sub> influent harness	2	3	5
Usage of salt per regeneration <sup>1</sup> , kg	1.0	1.5	2.0
Usage of water per regeneration (= discharge per regeneration), m <sup>3</sup>	0.08	0.1	0.12
Duration of regeneration, minutes		80–110	
Pressure drop in service mode, bar		0.5	
Inlet pressure, bar		2–6	
Electrical requirements		230 V, 50 Hz	
Power consumption, W		30	
Inlet/outlet pipe connections		3/4"	
Dry weight, kg	0	0	0
Overall dimensions, (Width × Depth × Height), cm	270 x 430 x 469	270 x 430 x 539	270 x 430 x 741

**INFLUENT WATER LIMITATIONS:**

Hardness	750 mg/L CaCO <sub>3</sub>
Iron	0.2 mg/L
Manganese	0.05 mg/L
Chemical Oxygen Demand	5 mg/L O <sub>2</sub>
Sediment prefilter rating	100 μm
Temperature of water <sup>2</sup>	+4...+30 °C