



AquaCube

From Direct Pumps and Tanks

Table of Contents

Product Description.....	2
Product Application.....	2
Product Location.....	3
AquaCube Services.....	3
AquaCube Features.....	4
Pump Overview.....	5
Technical Drawings.....	6
Curves and Specification.....	8
AquaCube Renderings.....	9



PRODUCT DESCRIPTION

The AquaCube has been designed to provide a self-contained, pre-assembled rainwater harvesting system that comes in two different sizes, 4320 litres and 5670 litres with larger options available upon request. The AquaCube can be installed as both a permanent installation or portable for use at different sites.

The AquaCube comes with all pumps, filters, and controls in one unit. This allows for a simple and straightforward installation with true 'plug and play' functionality.

Our AquaCube system can be used across various vertical markets and multiple building types. The system is perfectly suited for both new builds and existing retrofit sites.

PRODUCT APPLICATION

The AquaCube has been specifically designed to provide filtered rainwater for a variety of applications:

- ▶ Toilets and urinals
- ▶ Laundry
- ▶ Irrigation
- ▶ Vehicle and general cleaning

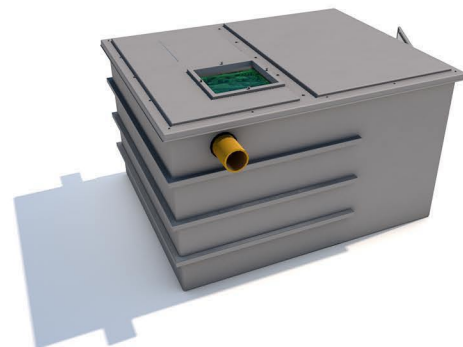

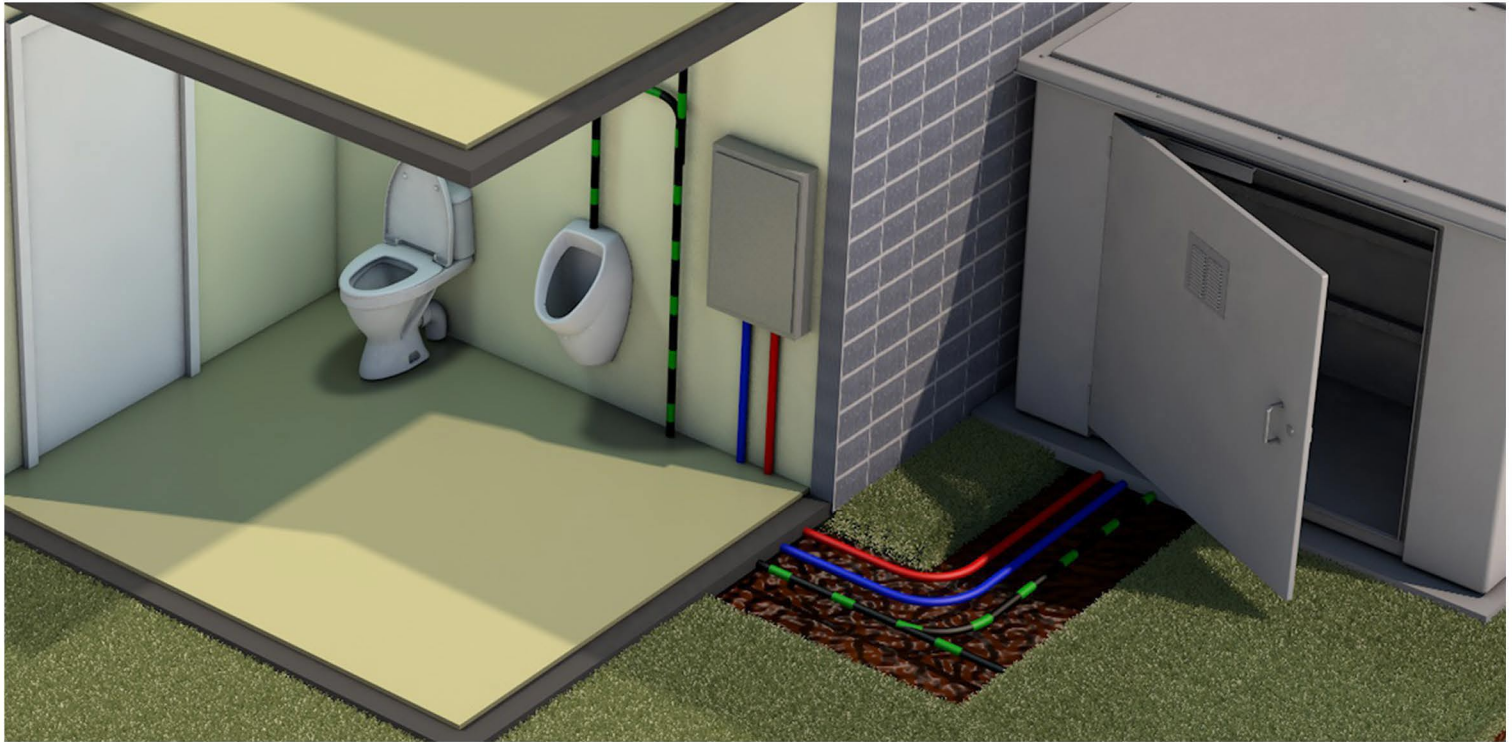

PRODUCT LOCATION

The AquaCube should be installed externally and within close proximity to your chosen building. Ideally the AquaCube should be close to all down pipes so that water from the roof area can be easily collected.

The AquaCube should be installed on a level concrete foundation which is capable of holding the full weight of the system when full with water.



Ample room for different pump configurations

AQUACUBE SERVICES



The AquaCube system has been designed to supply direct, pressurised water to your installed appliances through the use of a single pump which is mounted away from the stored water container. The AquaCube will require the following services:

- ▶ Incoming rainwater supply from the roof
- ▶ The tank overflow should be fitted to a soak away or storm drain
- ▶ Mains electrical supply
- ▶ Mains water supply for system top-up in low rainfall periods.
- ▶ Pressurised rainwater from the system booster pump feed.
- ▶ Control unit emergency warning pipe should be fitted so overflows are visible

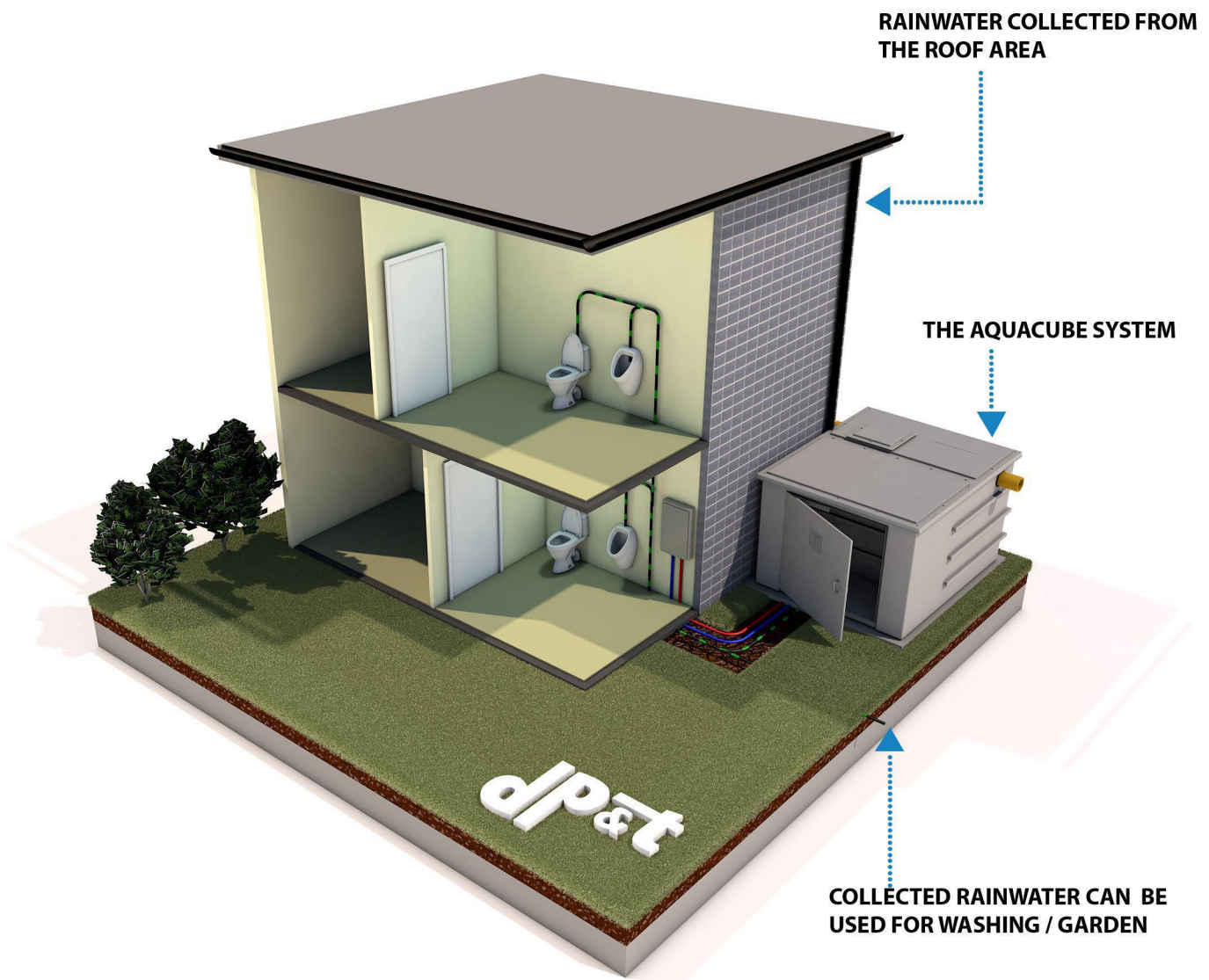
AquaCube Features at a Glance



PIPEWORK AND CABLE KEY

	MAINS WATER SUPPLY FOR TOP UP
	POWER SUPPLY CABLE
	PRESSURISED RAINWATER SUPPLY

Disclaimer: This diagram is to be used as a general overview of a typical rainwater harvesting system layout. It is not site specific and should not be relied upon for technical submittal or guidance.



Intelligent Pump & Controller

The control unit is designed as plug-in, compact system for use in domestic and light commercial applications.

The control unit has an integrated 7 litre break which is in accordance with EN1717 standards.

the system comes with an integrated self-priming centrifugal pump with automatic pressure control and a motor-controlled ball valve that switches between rainwater and drinking water operation.

The system is compact and whisper quiet as it is equipped with a sound-proof EPP housing.

the complete system is fully KIWA certified.

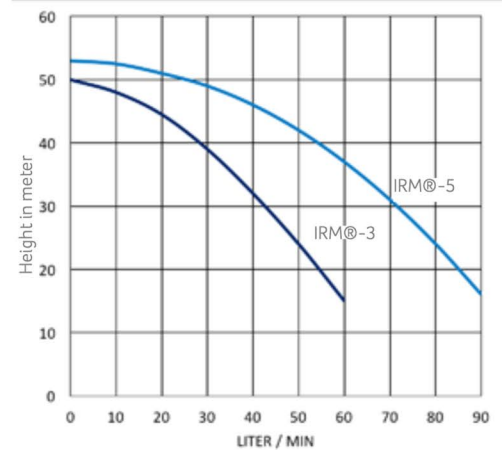
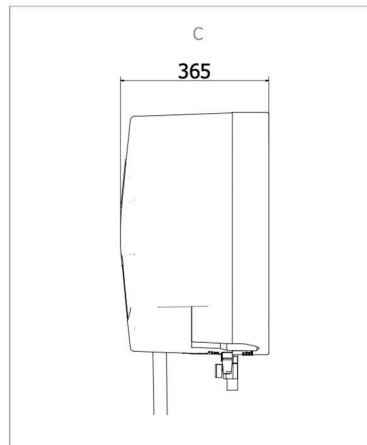
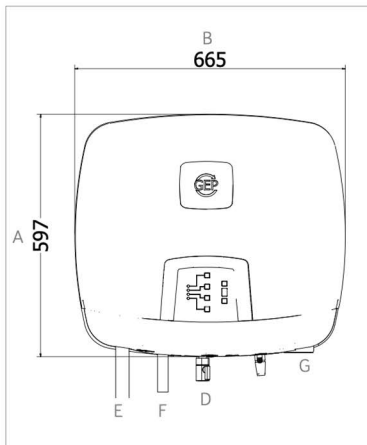

TECHNICAL DATA

Height A in mm:	596
Width B in mm:	662
Depth C in mm:	365
Drinking water connection D:	3/4"
Suction pipe E:	1"
Pressure line F:	1"
Emergency overflow G in mm:	Ø75
Volume breaktank in liters:	7

TECHNICAL SPECIFICATIONS

	IRM®-3	IRM®-5
Voltage in V:	230	230
Power in Watt:	1.100	1.350
Max. debiet in liter/min:	60	90
Max. opvoerHeight in m:	50	53
Leeggewicht in kg:	33	33
Aantal waaiers:	5	5
Condensator in µF:	20	25

MATERIAL

Name	Material
Sound insulating hood:	EPP
Breaktank:	HDPE
Press, suction side:	Messing
Impellers:	RVS
Pump housing:	RVS
Motor housing:	RVS
Air separator and guide wheel:	PPO (noryl)

4320L Technical Dimensions

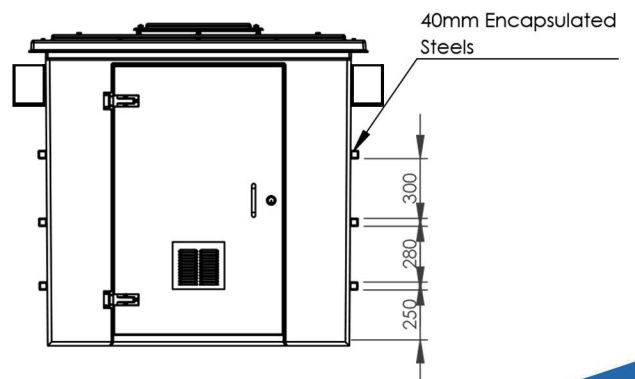
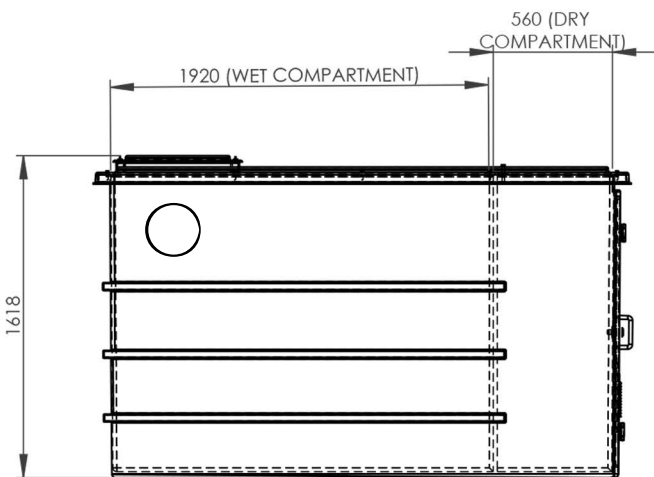
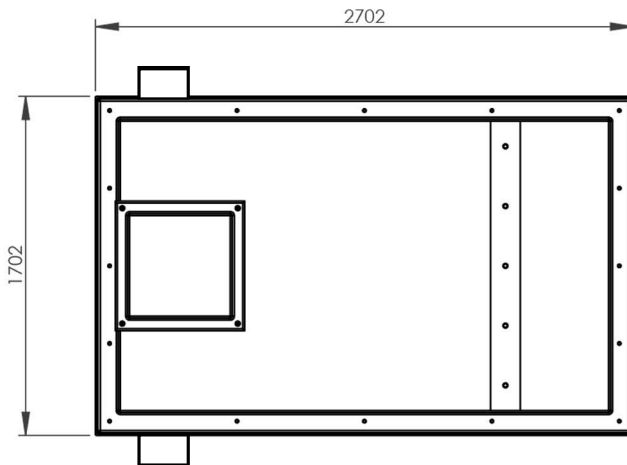

5670L Technical Dimensions

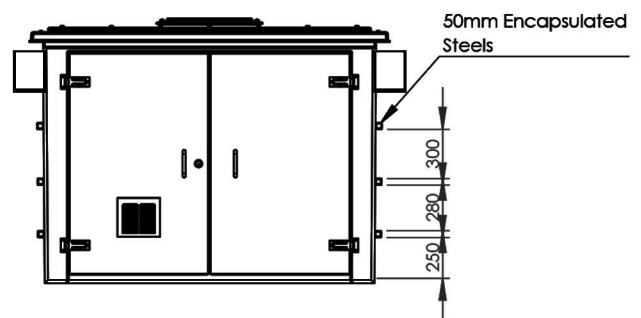
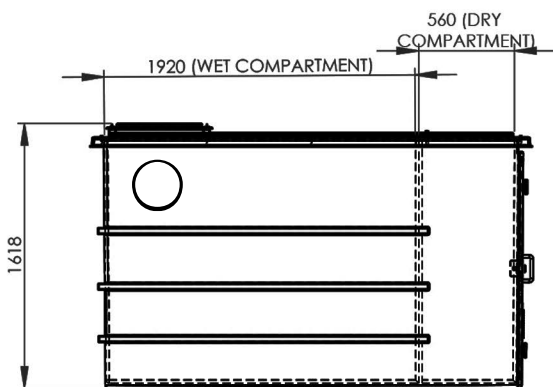
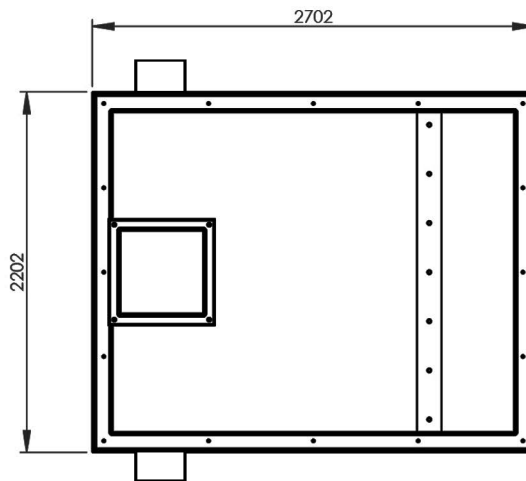

AQUACUBE RENDERINGS

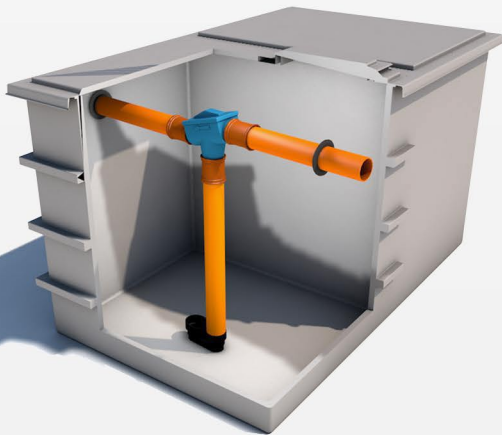

view of integrated Patronen filter.



Direct Pumps and Tanks Ltd
Unit 12 Cossall Industrial Estate
Ilkeston
Derbyshire
DE7 5UA
Tel: 0115 9444474
Fax: 0115 9442040
Email: info@dpandt.co.uk