

Installation instructions and maintenance GRAF rainwater reservoir Top-Tank

GRAF Top-Tank

Order No.: 323001



The points described in these instructions must be observed under all circumstances. All warranty rights are invalidated in the event of non-observance. Separate installation instructions are enclosed in the transportation packaging for all additional articles purchased from GRAF.

Missing instructions must be requested from us immediately.

The tank must be checked for any damage prior to insertion into the trench under all circumstances.

Missing instructions can be downloaded on www.graf.info or can be requested from GRAF.

Table of Contents

1. GENERAL NOTES	6
1.1 Safety	6
1.2 Identification obligation	6
2. INSTALLATION SET UP REQUIREMENTS	6
2.1 Assembly above ground	6
3. TRANSPORT AND STORAGE	6
3.1 Transport	6
3.2 Storage	6
4. TECHNICAL DATA	7
5. ASSEMBLY	7
5.1 Test installation	7
5.2 Installation tank	7
6. ASSEMBLY ABOVE GROUND	8
6.1 Joining multiple vessels	8
6.2 Laying connections	8
7. SERVICE AND MAINTENANCE	8

1

Deutsch

5

English

9

Français

13

Español

17

Italiano

1. General notes

1.1 Safety

The relevant accident prevention regulations according to BGV C22 have to be observed when conducting any works. Especially when inspecting tanks a second person is required for safety reasons.

Furthermore, the relevant regulations and standards have to be observed during installation, assembly, maintenance, repair, etc. You will find information about this in the related sections of these instructions.

During all works on the system respectively on system components the overall system has to be decommissioned and secured against unintentional restart at all times.

The company GRAF offers a comprehensive portfolio of accessories that are aligned with each other and can be developed into complete systems. Using deviating accessories can lead to impairments of the functionality of the system and thus to the liability for damages resulting thereof expiring.

1.2 Identification obligation

All lines and tapping points of process water have to be labelled with the words “**No drinking water**” in writing or visually (DIN 1988 part 2, section 3.3.2.) in order to avoid an accidental connection to the drinking water network even after years. Even when there are correct labels, irritations are possible, e.g. through children. That is why all tapping points of process water have to be installed with **child-proof** valves.

2. Installation set up requirements

2.1 Assembly above ground

- The tanks must be installed on an appropriate level and compacted surface that is free from sharp objects and stones.
- Notice must be taken that the tanks when filled will weigh 1,350 kg
- When there is a danger of frost the tanks must be completely emptied.
- When the tanks are to be installed in a closed room, it is necessary to ensure that there is a floor drainage system.
- Children must be supervised in the vicinity of the containers.

3. Transport and storage

3.1 Transport

The transport of the tanks may only be undertaken with the appropriate transport machinery. During the transport the tanks are to be secured against slipping or falling. If the tanks are secured for transportation with webbing straps, it is to be ensured that the tanks remain undamaged. Dragging or lifting the tanks with steel cables or chains is not permitted.

Stress and excess loading caused by impact are to be avoided. Under no circumstances are the tanks to be rolled or slid over the ground surface.

3.2 Storage

Any necessary temporary storage of the tanks must be on an appropriate level surface without sharp objects. During the storage it is important to avoid damage caused by the surrounding environment or foreign objects. Unauthorized persons must be kept away from the tanks.

4. Technical data

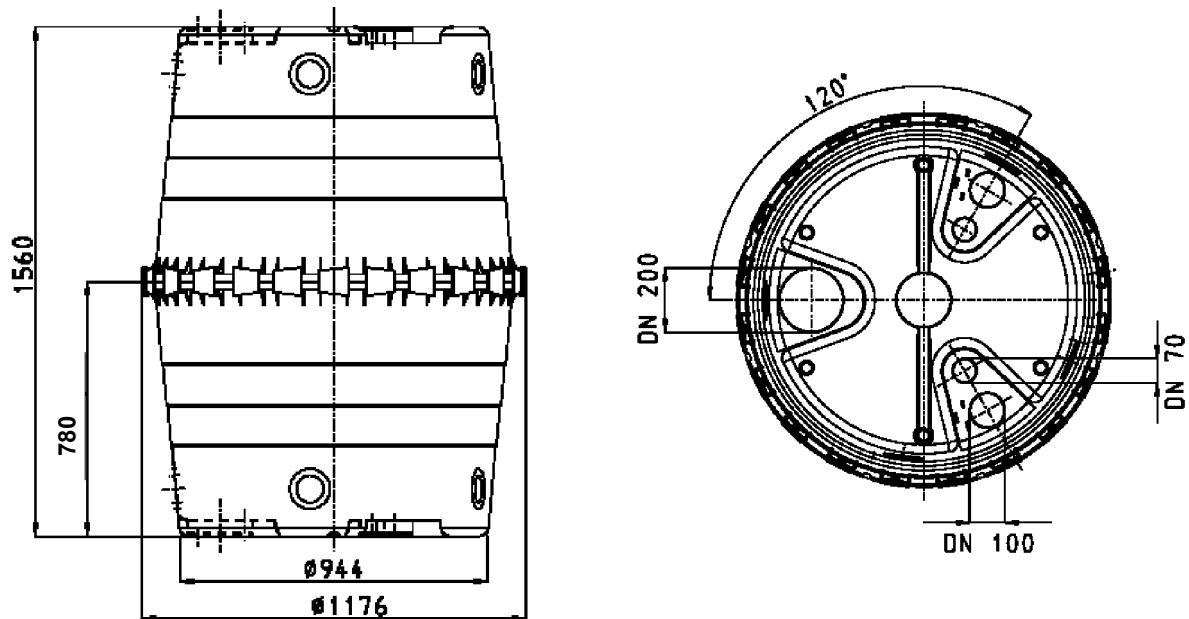

5. Assembly

5.1 Test installation

The container should be assembled on a trial basis before the final assembly to determine the position the following connections:

- Inlet
- Overflow

After opening the connections it is important to remove and clean all the drilling and sawing swarf from the tank.

5.2 Installation tank

The tanks consist of two identically constructed halves. For the assembly, the half with the closed side is positioned on the compacted and level ground surface. The profiled sealing ring is then well coated with lubricating soft soap and pressed with the ribbed side into the continuous perimeter of the inner seat recess.

Before the second half of the tank is set in position, the seal and the seat recess of the upper half must also be well coated with the lubricating soft soap. During the assembly it is important to ensure that the seal does not slip out of the seat recess.

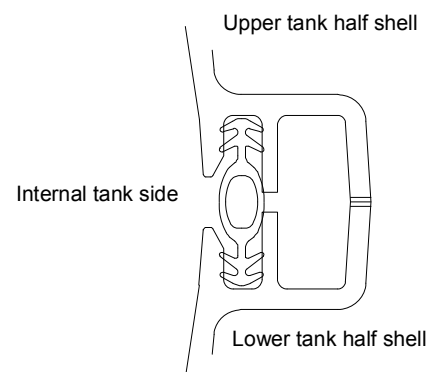

To secure the two halves, the connection clips are fitted first in a counter-clockwise direction and then in a clockwise direction. To assist in the assembly it may be necessary to press the two tank halves together with a number of G-clamps. To do this, position 3 to 4 G-clamps at equal intervals around the lip of the tank and then begin to tighten them evenly. Finally position the connection clips by hand and then drive them securely into place using a hammer with a piece of wood in between, the clips will then locate in the final engaged position.

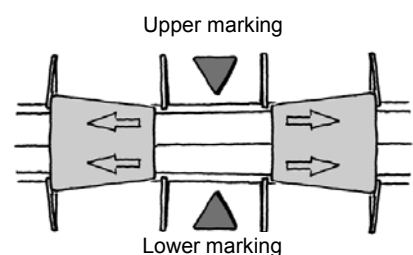

6. Assembly above ground

When installing the tanks above ground it is important to ensure that they are completely emptied when there is any danger of frost. Furthermore, the tanks must be installed on an appropriate level and compacted surface that is free from sharp objects and stones. Notice must be taken when installing the tanks that the total weight when filled will be 1,350 kg. The tanks should also be installed in a shaded area. When the tanks are to be installed in a closed room, it is necessary to ensure that there is a floor drainage system on hand. The tanks are not designed to work under pressure and therefore it is important to ensure that the overflow outlet has the same diameter as the inlet.

6.1 Joining multiple vessels

The coupling of two or more tanks is achieved by means of assembly areas moulded into the bases of the tanks using GRAF special seals and canalisation pipes. The openings are only to be undertaken with the special GRAF core drills (hole saw) in the appropriate sizes. It is important to note that the distance between the tanks is a minimum of 100 mm. The pipes must extend into the tank at least 200 mm. If two or more tanks are to be connected to one another then in addition to the lower connection (inlet) there must also be an upper connection to ensure ventilation.

6.2 Laying connections

The connection of the inlet and overflow is by means of the pre-drilled openings of the tank or by means of the pre-molded connection points intended for opening.

All the suction and pressure control lines must be installed and connected **above** the maximum water level.

7. Service and maintenance

The system as a whole has to be checked for leaks, cleanliness, and stability at least every three months.

The system as a whole should be maintained every 5 years. In doing so, all system components have to be cleaned and checked for functionality. Maintenance works should be conducted as follows:

- Empty tank completely
- Remove immovable residua using a pressure washer through the tank head
- Remove all contaminations from the tank
- Check all installation parts for proper seat

Garantia®, a trademark of Otto Graf GmbH

Otto Graf GmbH – Carl-Zeiss-Str. 2-6 – D-79331 Teningen – Tel.: 0049/(0)7641/589-0 – Fax: 0049/(0)7641/589-50
GRAF SARL – 45, Route d'Ernolsheim – F-67120 Dachstein Gare – Tel.: 0033/388497310 – Fax: 0033/388493280
GRAF Iberica – C/Marquès Caldes de Montbui, 114 baixos – ES-17003 Girona – Tel.: +34/972 913 767 – Fax: +34/972 913 766
GRAF Ltd – Maidstone, Kent – UK-ME16 8Ry – Phone: +44 (0) 16 22 68 65 50

