

SECTION A-A

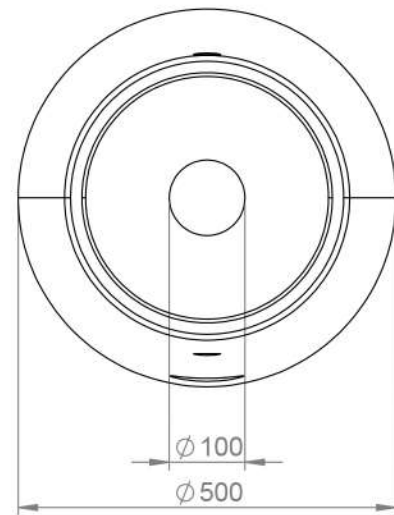
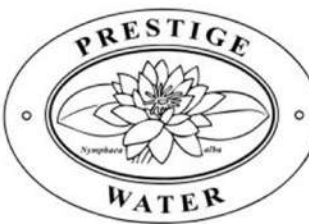

	PRODUCT TITLE	160L MANHATTAN CURVE	DRAWN	SS
	PRODUCT CODE	ManhCurve	CHECKED	HQ
	WEIGHT	11 KG	APPROVED	JP
	MATERIAL	MDPE	APPROVED DATE	17/11/2023
	PROPRIETARY & CONFIDENTIAL THE INFORMATION CONTAINED IN THIS DRAWING IS THE SOLE PROPERTY OF FREEFLUSH LIMITED. ANY REPRODUCTION IN PART OR AS A WHOLE WITHOUT THE WRITTEN PERMISSION OF FREEFLUSH LIMITED IS PROHIBITED.		SCALE	1:10
		SHEET/ SIZE	A3	
		REVISION	01	