

ASSEMBLY INSTRUCTIONS
FOR
**DYNALITE PRO SERIES FRONT BRAKE KIT WITH HUB
AND 10.75" DIAMETER VENTED ROTOR
1965 -1966 MUSTANG (4 LUG)**

PART NUMBER GROUP

140-12535

**DISC BRAKES SHOULD ONLY BE INSTALLED BY SOMEONE
EXPERIENCED AND COMPETENT IN THE INSTALLATION AND
MAINTENANCE OF DISC BRAKES
READ ALL WARNINGS**

WARNING

IT IS THE RESPONSIBILITY OF THE PERSON INSTALLING ANY BRAKE COMPONENT OR KIT TO DETERMINE THE SUITABILITY OF THE COMPONENT OR KIT FOR THAT PARTICULAR APPLICATION. IF YOU ARE NOT SURE HOW TO SAFELY USE THIS BRAKE COMPONENT OR KIT, YOU SHOULD NOT INSTALL OR USE IT. DO NOT ASSUME ANYTHING. IMPROPERLY INSTALLED OR MAINTAINED BRAKES ARE DANGEROUS. IF YOU ARE NOT SURE, GET HELP OR RETURN THE PRODUCT. YOU MAY OBTAIN ADDITIONAL INFORMATION AND TECHNICAL SUPPORT BY CALLING WILWOOD AT (805) 388-1188, OR VISIT OUR WEB SITE AT WWW.WILWOOD.COM. USE OF WILWOOD TECHNICAL SUPPORT DOES NOT GUARANTEE PROPER INSTALLATION. **YOU**, OR THE PERSON WHO DOES THE INSTALLATION MUST KNOW HOW TO PROPERLY USE THIS PRODUCT. IT IS NOT POSSIBLE OVER THE PHONE TO UNDERSTAND OR FORESEE ALL THE ISSUES THAT MIGHT ARISE IN YOUR INSTALLATION.

RACING EQUIPMENT AND BRAKES MUST BE MAINTAINED AND SHOULD BE CHECKED REGULARLY FOR FATIGUE, DAMAGE, AND WEAR.



Need Additional Information?
Use Your SmartPhone and
Jump to Our Technical Tips
Section on Our Web Site.



WARNING

**DO NOT OPERATE ANY VEHICLE ON UNTESTED BRAKES!
SEE MINIMUM TEST PROCEDURE WITHIN**

ALWAYS UTILIZE SAFETY RESTRAINT SYSTEMS AND ALL OTHER AVAILABLE SAFETY EQUIPMENT WHILE OPERATING THE VEHICLE

IMPORTANT • READ THE DISCLAIMER OF WARRANTY INCLUDED IN THE KIT

NOTE: Some cleaners may stain or remove the finish on brake system components. Test the cleaner on a hidden portion of the component before general use.

Important Notice - Read This First

Before any tear-down or disassembly begins, review the following information:

- Review the Wheel Clearance Diagram (Figure 2, page 3) to verify that there is adequate clearance with the wheels you will be using with the installation.
- Front brake kits do not include flex lines. OEM brake lines will not adapt to Wilwood calipers. Check the assembly instructions, or associated components section for brake line recommendations before assembly. In addition, Wilwood offers an extensive listing of brake lines and fittings on our web site: www.wilwood.com.
- Due to OEM production differences and other variations from vehicle to vehicle, the fastener hardware and other components in this kit may not be suitable for a specific application or vehicle.
- It is the responsibility of the purchaser and installer of this kit to verify suitability / fitment of all components and ensure all fasteners and hardware achieve complete and proper engagement. Improper or inadequate engagement can lead to component failure.

Photographic Tip

We suggest you take digital photos of the brake system setup before and during the disassembly procedure. This will aid in the event that something is not compatible with the new brake components and be a valuable tool to assist in the trouble-shooting process.

Exploded Assembly Diagram

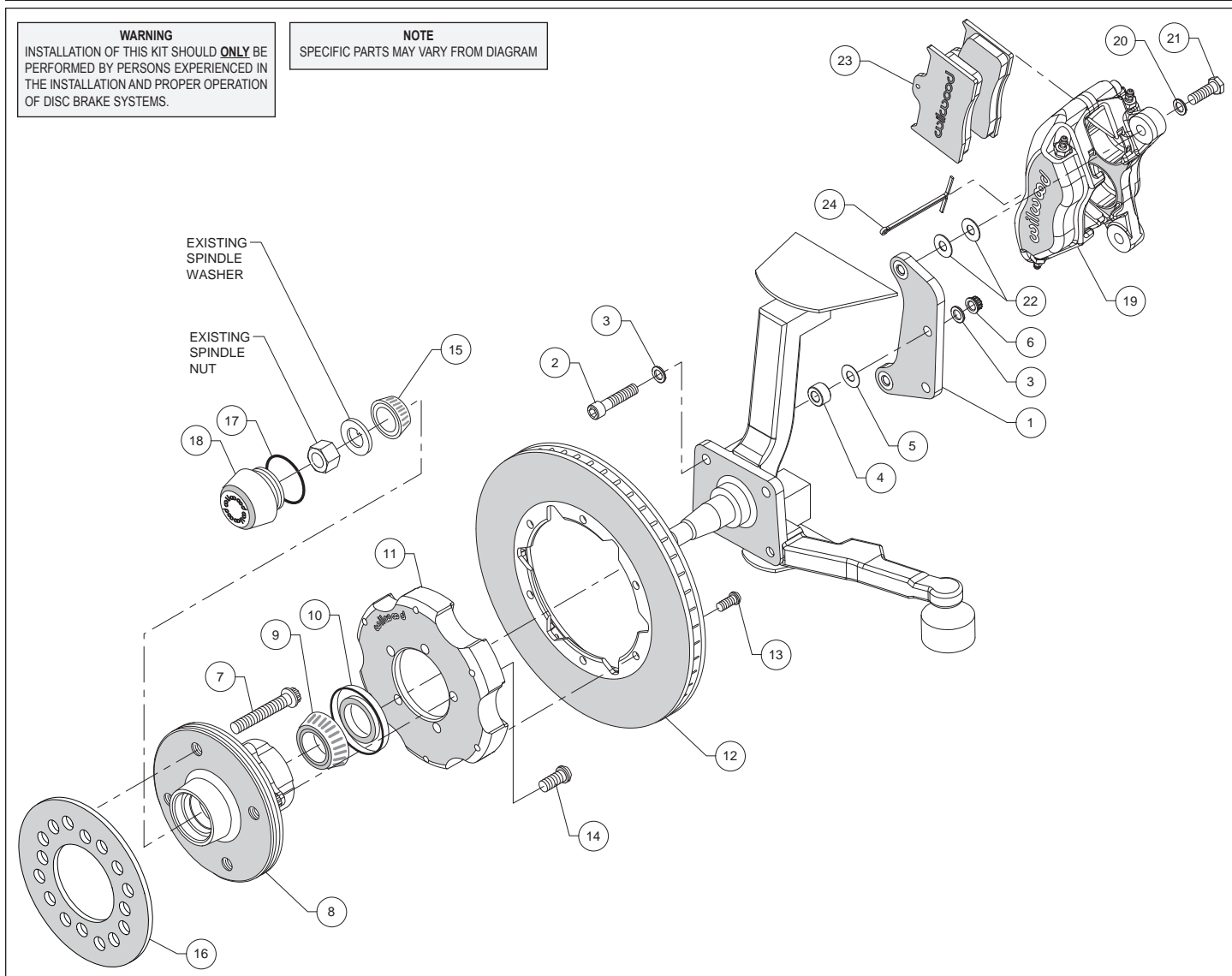

Figure 1. Typical Installation Configuration

Parts List

ITEM NO.	PART NO.	DESCRIPTION	QTY
1	249-12539/40	Bracket, Caliper Mounting (pair, one each, left and right)	1
2	230-1880	Bolt, 3/8-24 x 1.75 Long, Socket Head Cap Screw	4
3	240-10190	Washer, .391 I.D. x .625 O.D. x .063 Thick	8
4	240-7352	Spacer, .425 Long	4
5	240-10306	Shim, .016 Thick	8
6	230-9183	Nut, 3/8-24 Self-lock, 12 Point	4
7	230-2187	Stud, 1/2-20 x 1.75 Long, 12 Point	8
8	270-12537	Hub Assembly	2
9	370-3147	Cone, Inner Bearing	2
10	380-1562	Seal, Grease	2
11	170-12538	Hat, 1.07 Offset	2
12	160-5839	Rotor, .81" Thk x 10.75" Dia, 6 x 6.25" Bolt Circle	2
13	230-11934	Bolt, 5/16-18 x 0.75 Long, Button Head, Torx	12
14	230-11239	Bolt, 3/8-16 x 1.0 Long, Torx Button Head	10
15	370-1239	Cone, Outer Bearing	2
16	300-12583	Spacer, Wheel, .20 Thick	2
17	211-1674	O-ring	2
18	270-2158	Cap, Dust	2
19	120-6816	Caliper, Forged Dynalite	2
19A	120-6816-RD	Caliper, Forged Dynalite	2
20	240-10190	Washer, .391 I.D. x .625 O.D. x .063 Thick	4
21	230-10025	Bolt, 3/8-24 x 1.25 Long, Hex Head	4
22	240-1159	Shim, 0.035 inch Thick	16
23	150-8850K	Pad, BP-10, Axle Set	1
24	180-0055S	Pin, Cotter	2

NOTES: Part Number 230-12541 Bolt Kit, bracket to spindle, includes p/n's 230-1880, 230-9183, 240-10190, 240-10306 & 300-7352
 Part Number 230-3829 Bolt Kit, adapter plate to hub, includes part number 230-11239
 Part Number 230-12121 Bolt Kit, rotor to adapter plate, includes part number 230-11934
 Part Number 230-11861 Bolt Kit, caliper to bracket, includes part numbers 230-10025, 240-10190 and 240-1159
 Item 19A is an optional item available in the "-R" red caliper kits. Add "-R" to end of part number when ordering.

General Information

Installation of this kit should **ONLY** be performed by persons experienced in the installation and proper operation of disc brake systems. Before assembling the Wilwood front disc brake kit, double check the following items to ensure a trouble-free installation.

- Make sure this is the correct kit to match the exact make and model year of the vehicles spindle (i.e., hubs for a 1971 Mustang spindle will not fit a 1965 Mustang spindle).
- Verify wheel clearance utilizing Figure 2.
- Inspect the package contents against the parts list to ensure that all components and hardware are included.
- Verify the new hub stud pattern in this kit matches the lug pattern of the vehicles wheels.
- WARNING:** The wheel contact surfaces must seat completely on the face of the hub. If any contact surfaces overhang the outside diameter of the hub face, a 6.60" diameter x .20" thick steel spacer (item 25, Wilwood P/N 300-12583) MUST be used between the wheel and the hub.
- NOTE:** The OEM 14" 4-lug steel wheel requires use of wheel spacer (25) for clearance.
- Always tighten lug nuts to the wheel manufacturer's specifications.

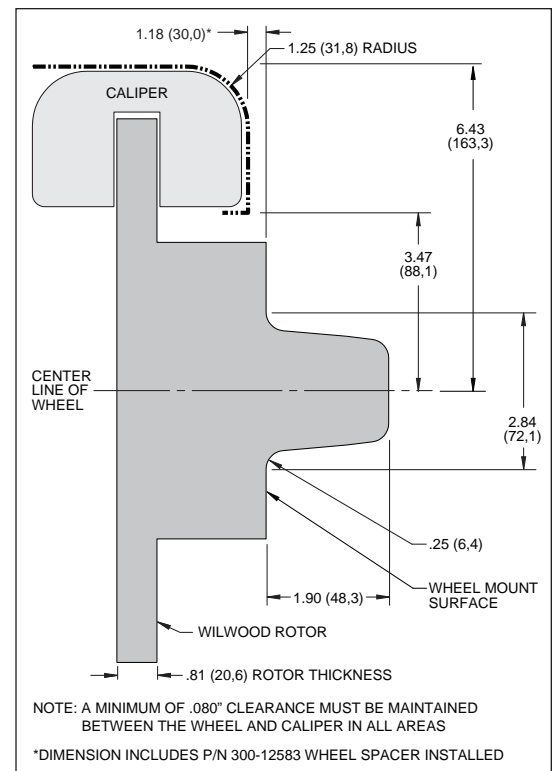

Figure 2. Wheel Clearance Diagram

Disassembly and Assembly Instructions

- Always recheck the lug nuts after test driving the vehicle at safe speeds. If they are NOT still tight, inspect the wheel-to-hub contact surfaces for damage and/or incomplete contact.
- As routine maintenance, periodically remove the wheels and inspect the wheel-to-hub contact surfaces for damage.
- It is the installer's responsibility to ensure that the wheels used with this hub kit are properly and securely installed. Some wheels may NOT be compatible with the hub in this kit.

Disassembly Instructions

- Disassemble the original equipment front brakes:

Raise the front wheels off the ground and support the front suspension according to vehicle manufacturer's instructions.

Remove the front wheels and completely disassemble the stock brake system down to the bare spindles. Save the Original Equipment Manufacturer (OEM) spindle nuts and nut locks (if any).

- Remove any nicks or burrs on the spindle mount faces that may interfere with the installation of the new brake components.
- Clean and de-grease the spindles and saved components.

Assembly Instructions (numbers in parenthesis refer to the parts list, on the preceding page and Figure 1): **CAUTION:** All mounting bolts must fully engage clinch nuts. Be sure to check that all bolts are either flush or protruding through flanged side of clinch nut after shimming, Figure 3.

- The caliper mount bracket (1) should initially be installed with clean, dry threads on the mounting bolts. Orient the bracket as shown in Figure 1 and Photo 1, and install using bolts (2), washers (3) and nuts (6). Place one spacer (4) and one shim (5) between the spindle to start, Figure 1. Ensure that the flanged heads of the clinch nuts in the bracket are facing outboard, Photo 1. Temporarily tighten the mounting nuts. **NOTE:** The bracket must fit squarely against the mounting points on the spindle. Inspect for interference from casting irregularities, machining ridges, burrs, etc.



Photo 1

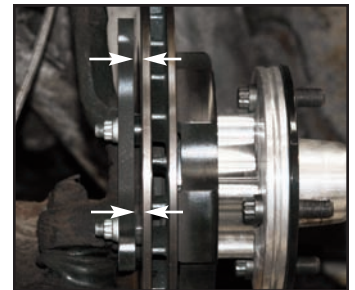

Photo 2

- Check that the bracket is aligned parallel to the rotor by assembling and installing hub/rotor per steps below, Photo 2. If not, add or subtract shims (5) between spacer and bracket, Figure 1.



Photo 3



Photo 4

- Once the bracket alignment is set, torque the bracket mount bolts and nuts to 30 ft-lbs.

- Install wheel studs (7) into the hub (8), Photo 3. Torque to 77 ft-lb.

- Pack the large inner bearing cone (9) with high temperature disc brake bearing grease (available from your local auto parts store) and install into the backside of the hub (8), Photo 4.

- Install the grease seal (10) by pressing into the backside of the hub (8), flush with the end of the hub, Photo 5.



Photo 5



Photo 6

- Mount the hat (11) to the hub (8) using bolts (14), as shown in Figure 1 and Photo 6. Using an alternating sequence, apply red Loctite® 271 to the threads, and torque to 55 ft-lb.

Assembly Instructions (Continued)

- Orient the rotor (12) and the hat/hub assembly (8/11) as shown in Figure 1 and Photo 7. Attach the rotor to the hat using bolts (13). Using an alternating sequence, apply red *Loctite*® 271 to the threads, and torque to 25 ft-lb.

- Pack the small outer bearing cone (15) with high temperature disc brake bearing grease and install into hub (8). Slide the hub/rotor/hat assembly onto the spindle. Secure using OEM spindle washer and spindle nut, Photo 8. Adjust bearings per OEM specifications. Install saved OEM nut lock (if any) and a new cotter pin (not supplied).

- Screw dust cap (18) into hub (8), Photo 9. Friction created by the o-ring (17) on the dust cap keeps it from unscrewing.

- NOTE:** Please reference the caution statement at the beginning of the assembly instructions. Mount the caliper (19) onto the caliper mounting bracket (1) using bolts (21) and washers (20), as shown in Figure 1. Initially place two .035" thick shims (22) on each bolt between the caliper and the bracket, Photo 10. Temporarily tighten the mounting bolts and view the rotor (12) through the top opening of the caliper. The rotor should be centered in the caliper, Photo 11. If not, adjust by adding or subtracting shims between the bracket and the caliper. Always use the same amount of shims on each of the two mounting bolts. **NOTE:** The end of each bolt must be flush with or slightly protruding from the head of the clinch nut, as shown in Figure 3. If necessary place spare shims between washer (20) and caliper mounting ear to achieve the proper clinch nut engagement. Once the caliper alignment and clinch nut engagement are correct, remove the bolts one at a time, apply red *Loctite*® 271 to bolt threads, and torque to 40 ft-lb.

- Install the disc brake pads (23) into the caliper, with the friction material facing the rotor (12), and secure in place using cotter pin (24), Photo 12.

- Install wheel spacer (25) as shown in Figure 1 and Photo 13. Temporarily install wheel and torque lug nuts to manufacturer's specification. Ensure that the wheel rotates freely without any interference. **NOTE:** Wheel spacer (25) MUST be used if any wheel contact surfaces overhang the outside diameter of the hub face. See warning on page 3.

- NOTE:** OEM rubber brake hoses generally cannot be adapted to Wilwood calipers. The caliper inlet fitting is a 1/8-27 NPT. The preferred method is to use steel adapter fittings at the caliper, either straight, 45 or 90 degree and enough steel braided line to allow for full suspension travel and turning radius, lock to lock. **Carefully route hoses to prevent contact with moving suspension, brake or wheel components.** **NOTE:** Wilwood hose kits are designed for use in many different vehicle applications and it is the installer's responsibility to properly route and ensure adequate clearance and retention for brake hose components. Wilwood offers universal brake flex line hose kits, order P/N 220-7056 for the 14 inch length, P/N 220-7699



Photo 7



Photo 8



Photo 9

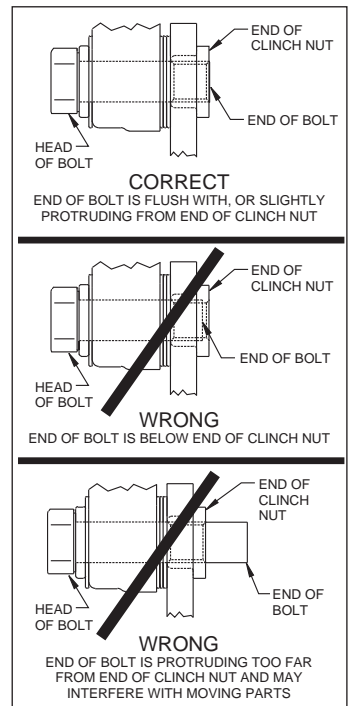

Figure 3. Clinch Nut Engagement Diagram



Photo 10

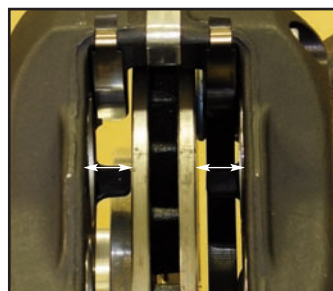

Photo 11

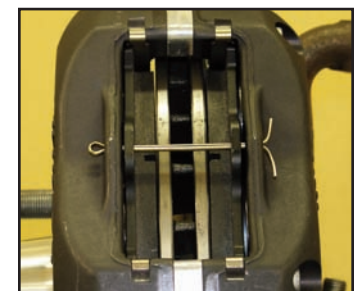

Photo 12

Assembly Instructions (Continued)

for the 16 inch length, or P/N 220-8307 for the 18 inch length. Hose kits include hoses, fitting, etc., all in one package for this application.



Photo 13

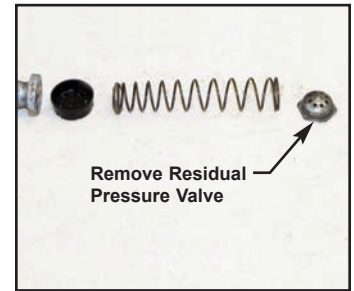

Photo 14

•**NOTE:** Specified brake hose kits may not work with all Years, Makes and Models of vehicle that this brake kit is applicable to, due to possible OEM manufacturing changes during a production vehicle's life. It is the installer's responsibility to ensure that all fittings and hoses are the correct size and length, to ensure proper sealing and that they will not be subject to crimping, strain and abrasion from vibration or interference with suspension components, brake rotor or wheel.

•In absence of specific instructions for brake line routing, the installer must use his best professional judgment on correct routing and retention of lines to ensure safe operation. Test vehicle brake system per the 'minimum test' procedure stated within this document before driving. After road testing, inspect for leaks and interference. Initially after install and testing, perform frequent checks of the vehicle brake system and lines before driving, to confirm that there is no undue wear or interference not apparent from the initial test. Afterwards, perform periodic inspections for function, leaks and wear in a interval relative to the usage of vehicle.

•It is highly recommended that a Wilwood proportioning valve (P/N 260-8419) be plumbed into the line that feeds both rear wheels. When installed and adjusted properly, it can reduce the chances of potentially dangerous rear-wheel lock up during hard braking.

Master Cylinder

•This brake kit may be used with the OEM single circuit master cylinder. However, the residual pressure valve must be removed from inside the master cylinder to prevent unwanted front brake drag, Photo 14. **NOTE:** Care must be taken not to damage the master cylinder seals when reinstalling the piston assembly.

•For increased safety, and improved pedal feel, we recommend replacing the OEM master cylinder with a dual circuit Wilwood 7/8" bore tandem master cylinder (P/N 260-9439). The new master cylinder will require replumbing of some brake lines.

•Bleed the brake system, referring to the additional information and recommendations on page 7 for proper bleeding instructions. Check system for leaks after bleeding.

•Install the wheel and torque to manufacturer's specifications. **NOTE:** Wheel spacer (25) MUST be used if any wheel contact surfaces overhang the outside diameter of the hub face. See warning on page 3.

Additional Information and Recommendations

•Fill and bleed the new system with Wilwood Hi-Temp° 570 grade fluid or higher. For severe braking or sustained high heat operation, use Wilwood EXP 600 Plus Racing Brake Fluid. Used fluid must be completely flushed from the system to prevent contamination.
NOTE: *Silicone DOT 5 brake fluid is **NOT** recommended for racing or performance driving.*

•To properly bleed the brake system, begin with the caliper farthest from the master cylinder. Bleed the outboard bleed screw first, then the inboard. Repeat the procedure until all calipers in the system are bled, ending with the caliper closest to the master cylinder.
NOTE: *When using a new master cylinder, it is important to bench bleed the master cylinder first.*

•If the master cylinder is mounted lower than the disc brake calipers, some fluid flowback to the master cylinder reservoir may occur, creating a vacuum effect that retracts the caliper pistons into the housing. This will cause the pedal to go to the floor on the first stroke until it has “pumped up” and moved all the pistons out against the pad again. A Wilwood in-line two pound residual pressure valve, installed near the master cylinder will stop the fluid flowback and keep the pedal firm and responsive.

•Test the brake pedal. It should be firm, not spongy and stop at least 1 inch from the floor under heavy load.
If the brake pedal is spongy, bleed the system again.

If the brake pedal is initially firm, but then sinks to the floor, check the system for fluid leaks. Correct the leaks (if applicable) and then bleed the system again.

If the brake pedal goes to the floor and continued bleeding of the system does not correct the problem, a master cylinder with increased capacity (larger bore diameter) will be required. Wilwood offers various lightweight master cylinders with large fluid displacement capacities.

•**NOTE:** *With the installation of after market disc brakes, the wheel track may change depending on the application. Check your wheel offset before final assembly.*

•On some models of disc brake spindles there are “ears” where the OEM calipers were mounted and these “ears” interfere with the assembly of the Wilwood disc brake kit. If it becomes necessary to remove these “ears”, remove as little as possible being careful not to cut away any of the mounting holes that may be required to bolt on the caliper mounting bracket.

•If after following the instructions, you still have difficulty in assembling or bleeding your Wilwood disc brakes, consult your local chassis builder, or retailer where the kit was purchased for further assistance.

Brake Testing and Pad Bedding

WARNING • DO NOT DRIVE ON UNTESTED BRAKES BRAKES MUST BE TESTED AFTER INSTALLATION OR MAINTENANCE MINIMUM TEST PROCEDURE

- Make sure pedal is firm: Hold firm pressure on pedal for several minutes, it should remain in position without sinking. If pedal sinks toward floor, check system for fluid leaks. DO NOT drive vehicle if pedal does not stay firm or can be pushed to the floor with normal pressure.
- At very low speed (2-5 mph) apply brakes hard several times while turning steering from full left to full right, repeat several times. Remove the wheels and check that components are not touching, rubbing, or leaking.
- Carefully examine all brake components, brake lines, and fittings for leaks and interference.
- Make sure there is no interference with wheels or suspension components.
- Drive vehicle at low speed (15-20 mph) making moderate and hard stops. Brakes should feel normal and positive. Again check for leaks and interference.
- Always test vehicle in a safe place where there is no danger to (or from) other people or vehicles.
- Always wear seat belts and make use of all safety equipment.

PAD BEDDING STEPS:

Once the brake system has been tested and determined safe to operate the vehicle, follow these steps for bedding of all pad materials and rotors. This procedure should be performed on a race track or other safe location where you can safely and legally obtain speeds up to 65 MPH while also being able to rapidly decelerate.

- Proceed with a series of 8-10 hard stops from 55-65 MPH down to 25 MPH allowing 20-30 seconds of cool down time between each stop.
- Drive at a moderate cruising speed, with the least amount of brake contact possible, until most of the heat has dissipated from the brakes. Avoid sitting stopped with the brake pedal depressed to hold the car in place during this time. Park the vehicle and allow the brakes to cool to ambient air temperature.

Associated Components

<u>PART NO.</u>	<u>DESCRIPTION</u>
260-1874	Wilwood Residual Pressure Valve (2 lb for disc brakes)
260-1876	Wilwood Residual Pressure Valve (10 lb for drum brakes)
260-8419	Wilwood Proportioning Valve
290-0632	Wilwood Racing Brake Fluid (Hi-Temp° 570) (12 oz)
290-6209	Wilwood Racing Brake Fluid (EXP 600 Plus) (16.9 oz)
340-1285	Wilwood Floor Mount Brake Pedal (with balance bar)
340-1287	Wilwood Swing Mount Brake Pedal (with balance bar)
260-6764	Wilwood 3/4 inch High Volume Aluminum Master Cylinder
260-6765	Wilwood 7/8 inch High Volume Aluminum Master Cylinder
260-6766	Wilwood 1 inch High Volume Aluminum Master Cylinder
260-4893	1-1/16 inch Tandem Master Cylinder (aluminum housing)
250-2406	Mounting Bracket Kit (tandem master cylinder)
260-8555	Wilwood 1 inch Aluminum Tandem Chamber Master Cylinder
260-8556	Wilwood 1-1/8 inch Aluminum Tandem Chamber Master Cylinder
350-2038	1971 - 1973 Pinto Rack and Pinion (new, not rebuilt)
270-2016	Quick Release Steering Hub (3/4 inch shaft)
270-2017	Quick Release Steering Hub (5/8 inch shaft)
220-7056	Flexline Kit, Universal, 14 Inch, Domestic
220-7699	Flexline Kit, Universal, 16 Inch, Domestic
220-8307	Flexline Kit, Universal, 18 Inch, Domestic