

**ASSEMBLY INSTRUCTIONS**  
FOR  
**SUPERLITE 6 BIG BRAKE FRONT HUB KIT**  
**WITH 14.00" DIAMETER VENTED ROTOR**

**1979 - 1981 CAMARO (DISC SPINDLE)**

PART NUMBER GROUP

**140-10493**

**DISC BRAKES SHOULD ONLY BE INSTALLED BY SOMEONE  
EXPERIENCED AND COMPETENT IN THE INSTALLATION  
AND MAINTENANCE OF DISC BRAKES**

**READ ALL WARNINGS**

**WARNING**

IT IS THE RESPONSIBILITY OF THE PERSON INSTALLING ANY BRAKE COMPONENT OR KIT TO DETERMINE THE SUITABILITY OF THE COMPONENT OR KIT FOR THAT PARTICULAR APPLICATION. IF YOU ARE NOT SURE HOW TO SAFELY USE THIS BRAKE COMPONENT OR KIT, YOU SHOULD NOT INSTALL OR USE IT. DO NOT ASSUME ANYTHING. IMPROPERLY INSTALLED OR MAINTAINED BRAKES ARE DANGEROUS. IF YOU ARE NOT SURE, GET HELP OR RETURN THE PRODUCT. YOU MAY OBTAIN ADDITIONAL INFORMATION AND TECHNICAL SUPPORT BY CALLING WILWOOD AT (805) 388-1188, OR VISIT OUR WEB SITE AT [WWW.WILWOOD.COM](http://WWW.WILWOOD.COM). USE OF WILWOOD TECHNICAL SUPPORT DOES NOT GUARANTEE PROPER INSTALLATION. YOU, OR THE PERSON WHO DOES THE INSTALLATION MUST KNOW HOW TO PROPERLY USE THIS PRODUCT. IT IS NOT POSSIBLE OVER THE PHONE TO UNDERSTAND OR FORESEE ALL THE ISSUES THAT MIGHT ARISE IN YOUR INSTALLATION.

RACING EQUIPMENT AND BRAKES MUST BE MAINTAINED AND SHOULD BE CHECKED REGULARLY FOR FATIGUE, DAMAGE, AND WEAR.



**WARNING**

**DO NOT OPERATE ANY VEHICLE ON UNTESTED BRAKES!**  
**SEE MINIMUM TEST PROCEDURE WITHIN**

**ALWAYS** UTILIZE SAFETY RESTRAINT SYSTEMS AND ALL OTHER AVAILABLE SAFETY EQUIPMENT WHILE OPERATING THE VEHICLE.

**IMPORTANT • READ THE DISCLAIMER OF WARRANTY INCLUDED IN THE KIT.**

NOTE: Some cleaners may stain or remove the finish on brake system components. Test the cleaner on a hidden portion of the component before general use.

## Important Notice - Read This First

Before any tear-down or disassembly begins, review the following information:

- A substantial amount of modifications are required to the stock steering arm/spindle. These include drilling and tapping two holes as well as removing two “ears” that will interfere with the assembly of the Wilwood disc brake kit. It is recommended that these modifications be performed by a qualified machine shop. Keep in mind that this may require a substantial amount of time. Therefore, the vehicle may be inoperable for longer than anticipated.
- Review the wheel clearance diagram (figure 3, page 5) to verify that there is adequate clearance with the wheels you will be using with the installation.
- Front brake kits do not include flex lines. OEM brake lines will not adapt to Wilwood calipers. Check the assembly instructions, or associated components section for brake line recommendations before assembly. In addition, Wilwood offers an extensive listing of brake lines and fittings on our web site: [www.wilwood.com](http://www.wilwood.com).
- Due to OEM production differences and other variations from vehicle to vehicle, the fastener hardware and other components in this kit may not be suitable for a specific application or vehicle.
- It is the responsibility of the purchaser and installer of this kit to verify suitability / fitment of all components and ensure all fasteners and hardware achieve complete and proper engagement. Improper or inadequate engagement can lead to component failure.

## General Information and Disassembly Instructions

Installation of this kit should **ONLY** be performed by persons experienced in the installation and proper operation of disc brake systems. Before assembling the Wilwood front disc brake kit, double check the following items to ensure a trouble-free installation.

- Make sure this is the correct kit to match the exact make and model year of the vehicles spindle (i.e., hubs for a 1975 Camaro spindle will not fit a 1992 Camaro spindle).
- Verify the hub stud pattern in this kit (5 x 4.50 or 5 x 4.75) matches the stud pattern of the vehicles wheels.
- Verify wheel clearance utilizing figure 3.
- Inspect the package contents against the parts list to ensure that all components and hardware are included.

### Disassembly Instructions

- Disassemble the original equipment front brakes:

Raise the front wheels off the ground. Support the front suspension according to the vehicle manufacturer’s instructions.

Remove caliper slide pins. Disconnect brake hose from brake line at the chasis. Remove brake caliper, pads and hose as an assembly. Remove center cap, cotter pin, nut lock and wheel bearing nut and washer. Remove brake rotor and hub assembly, including wheel bearings. Remove disc brake dust shield assembly by removing attaching bolts. Dust shield and bolts will not be reused in assembly.

- Clean and de-grease the spindles. Remove all nicks or burrs on the spindle snout and threads. Remove any of the backing plate gasket which may remain on the spindles. Remove any scale or rust from the gasket area.

## Steering Arm / Spindle Modifications

These modifications should be performed by a qualified machinist. Refer to Figure 1 on the following page as necessary (numbers in parenthesis refer to the parts list on page three). Only one view of the steering arm/spindle is shown, but the modifications need to be performed on both steering arm/spindles.

### Modification Procedure

The two stock holes that will be used to mount the caliper mounting bracket (1) need to be modified (figure 1). Drill a .332 diameter hole through both holes, then tap 3/8-24 UNF (fine thread). Countersink the holes to .438 x 90°. The “ears” that protrude to form a “C” shape need to be removed to facilitate the installation of the Wilwood caliper (22). Using the caliper mounting bracket (16) as a template, mark two cut marks on the steering arm. Remove as little as necessary from the “C” shape, being careful not to cut away any of the mounting holes required to bolt on the caliper mounting bracket (1).

## Steering Arm / Spindle Modifications (Continued)

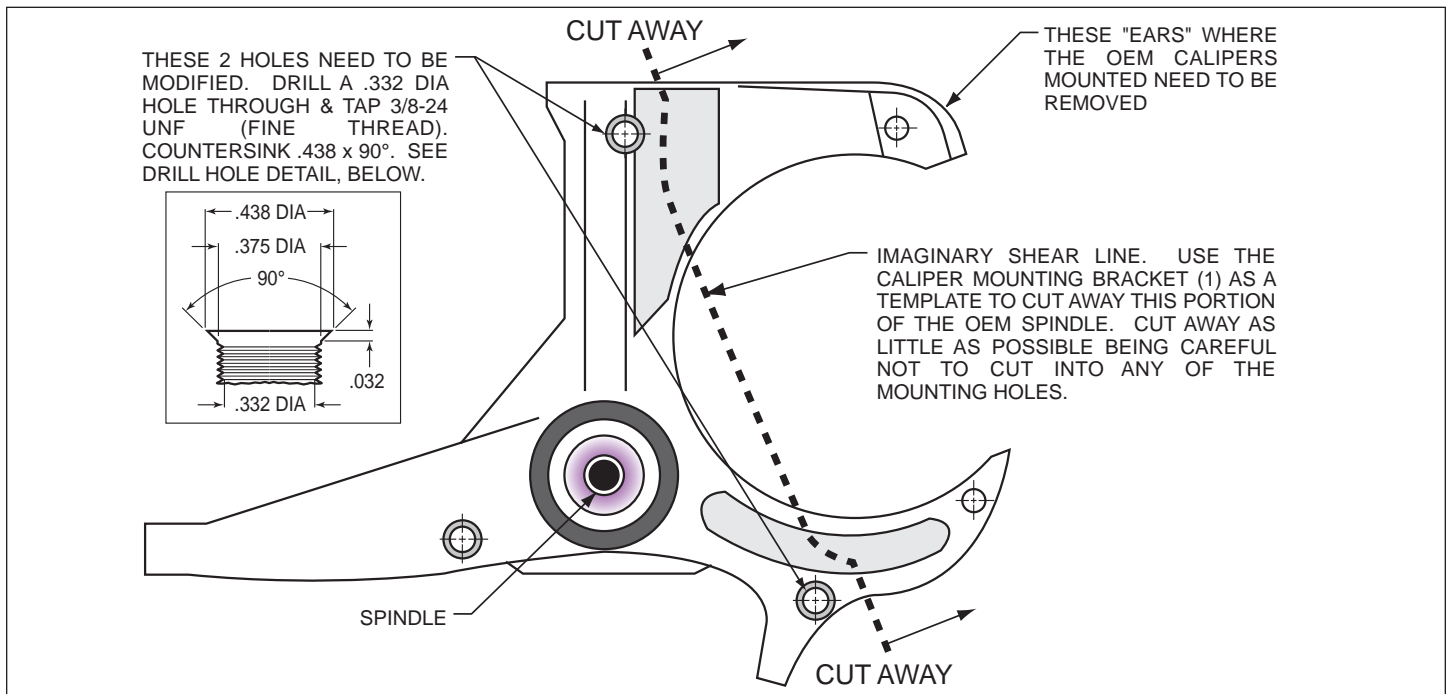

Figure 1. Steering Arm / Spindle Modifications

## Parts List

ITEM NO.	PART NO.	DESCRIPTION	QTY
1	250-10488	Bracket, Flat, Mounting	2
2	230-10449	Bolt, 3/8-24 x 1.00 Long, FHCS	4
3	230-6959	Stud, 1/2-20 x 2.00 Long, 12 Point	10
4	270-10494	Hub Assembly	2
5	370-0879	Cone, Inner Bearing	2
6	380-1165	Seal, Grease	2
7	160-8402/03	Rotor, 1.10" Thk x 14.00" Dia, 12 x 8.75" Bolt Circle	2
7A	160-8400-01-BK	Rotor, Drilled and Slotted (pair, one each, left and right)	2
8	170-10489	Hat, 5 x 4.50/4.75	2
9	240-2509	Washer, .250 I.D. x .500 O.D. x .063 Thick	24
10	230-6737	Bolt, 1/4-20 x 1.00 Long, 12 PTCS	24
11	230-7029	Bolt, 1/4-20 x .50 Long, FHCS	6
12	370-0933	Cone, Outer Bearing	2
13	240-2283	Washer, Spindle 3/4	2
14	211-1674	O-ring	2
15	270-2158	Cap, Dust	2
16	250-9840	Bracket, Caliper Mounting	4
17	230-10023	Bolt, 7/16-20 x 1.75 Long, HXHD	4
18	240-9069	Washer, .453 I.D. x .750 O.D. x .063 Thick	4
19	300-8359	Sleeve, .437 I.D. x .479 O.D. x .500 Long	4
20	300-9283	Spacer, .170 Long	4
21	240-1848	Washer, .441 I.D. x 1.003 O.D. x .030 Thick	12
22	120-8079/80-FS	Caliper, Superlite 6R	2
22A	120-8079/80-FSR	Caliper, Superlite 6R, Red	2
23	230-9077	Stud, 3/8-16, 3/8-24 x 3.15 Long	4
24	300-7392	Spacer, .573 Long	4
25	240-1159	Washer, .375 I.D. x .875 O.D. x .035 Thick	16
26	240-2510	Washer, .391 I.D. x .625 O.D. x .057 Thick	4
27	230-9183	Nut, 3/8-24, Self-Lock, 12 Point	4
28	15E-8855K	Pad, BP-10, Axle Set	1
29	240-3902	Washer, .441 I.D. x 1.000 O.D. x .016 Thick	4

### NOTES:

Part Number 230-4572, Bolt Kit, Rotor to Hat includes part numbers 230-6737 and 240-2509

Part Number 230-7032, Bolt Kit, Hat to Hub includes part number 230-7029

Part Number 250-10495 Bracket Kit, Caliper Mounting includes p/n's 230-9079, 230-9183, 240-1159, 240-2510, 250-9840 & 300-7392

Part Number 230-10490, Bolt Kit, Bracket to Bracket includes p/n's 230-10023, 240-1848, 240-3902, 240-9069, 300-8359 & 300-9283

Part Number 230-10491, Bolt Kit, Bracket to Spindle includes part number 230-10449

Item 7A is an optional item and is included in the (D) drilled kits. Add -D to end of part number when ordering

Item 22A is an optional item and is included in the (R) kits. Add -R to end of part number when ordering

## Exploded Assembly Diagram

(Numbers refer to the parts list on the previous page).

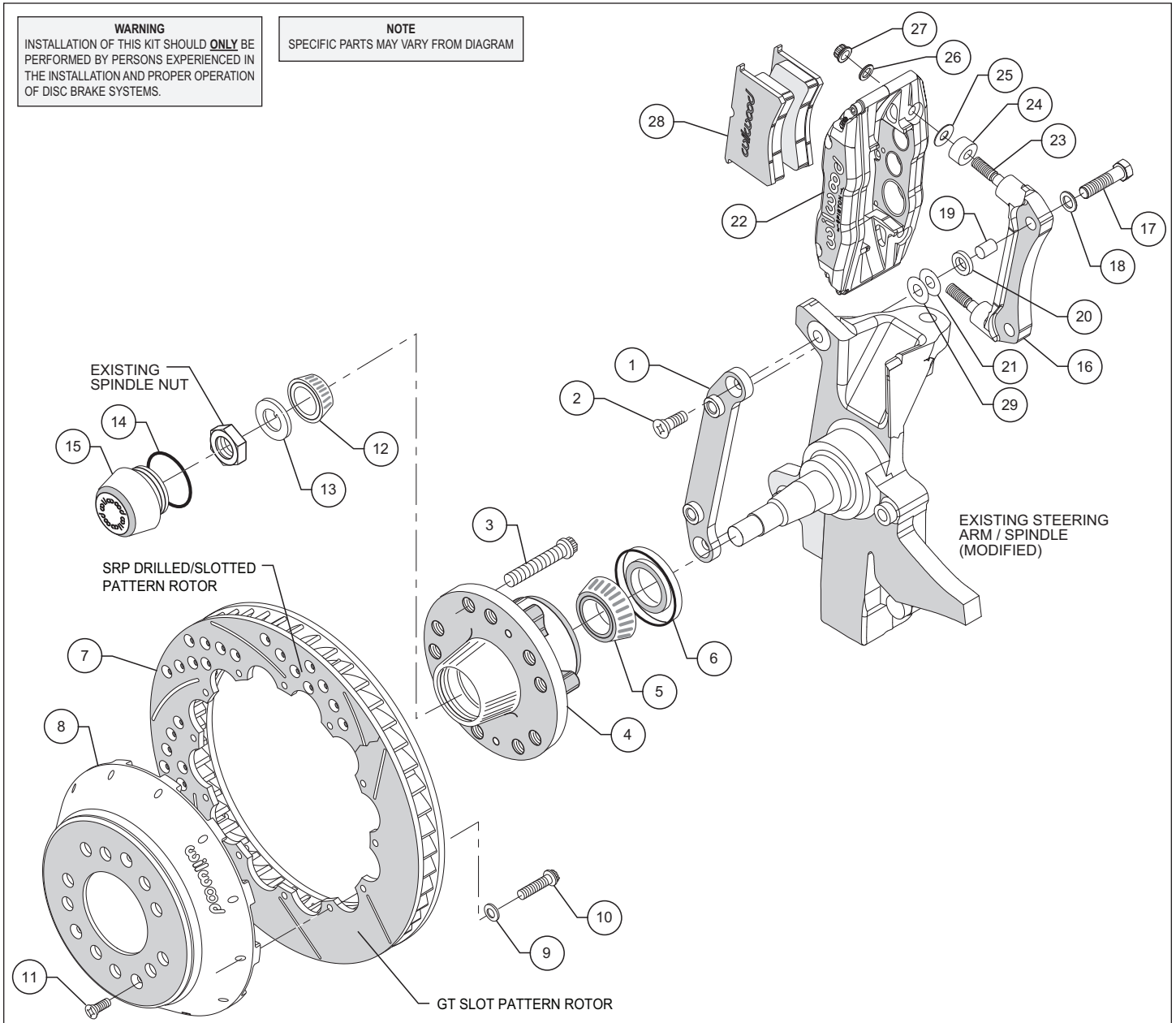

Figure 2. Typical Installation Configuration

## Assembly Instructions

**Assembly Instructions** (numbers in parenthesis refer to the part list/diagram on the preceding page): **CAUTION:** All mounting bolts must fully engage insert nuts. Be sure to check that all bolts are either flush or protruding through flanged side of insert nut after shimming.

- Position the flat mounting bracket (1) against the outboard side of the spindle. Slide the mounting bolts (2) through the bracket and into the threaded spindle holes and tighten. The bracket must tighten squarely against the outboard side of the spindle face/upright. Inspect for interference from casting irregularities, machining ridges, burrs, etc. If everything fits correctly, remove the mounting bolts (2) and coat threads with red *Loctite*® 271 and reinstall. Torque two bolts (2) to 30 ft-lb. **NOTE:** Be sure the heads of the flat caliper bracket (1) insert nuts are facing outward toward the wheel.

- Install five new wheel studs (3) into the hub (4). Torque to 77 ft-lb. **NOTE:** There are two five lug patterns in the hub (5 x 4.50 and 5 x 4.75). Make sure of the correct hole pattern for the correct wheel application before installing studs into hub.

- Pack the large inner bearing cone (5) with high temperature disc brake bearing grease (available from your local auto parts store) and install into the backside of the hub (4).

## Assembly Instructions (Continued)

- Install the grease seal (6) by pressing into the backside of the hub (4).

- Pack the small outer bearing cone (12) with high temperature disc brake bearing grease and install into front side of the hub (4). Slide the hub assembly (4, 5, 6 and 12) onto the spindle. Secure using spindle washer (13), stock adjusting nut, and nut locking device. Adjust wheel bearing pre-load per Original Equipment Manufacturer (OEM) specifications.

- Install the O-ring (14) and the dust cap (15) into the hub (4). **NOTE:** O-ring (14) friction will not allow cap (15) to unscrew on its own.

- With the larger I.D. side of the rotor (7) facing away from the hat (8), bolt rotor (7) to hat (8) through the backside of the rotor using washers (9) and bolts (10). Torque bolts (10) in an alternating sequence to 85 **in-lb**. Safety wire bolts (10) using standard 0.032 inch diameter stainless steel safety wire as shown in Figure 4. Please refer to Wilwood's data sheet DS-386 (available at [www.wilwood.com/pdf/ds386.pdf](http://www.wilwood.com/pdf/ds386.pdf)) for complete safety wire installation instructions.

- Slide the rotor/hat assembly over the studs (3) in the hub (4) taking care to align the small countersunk holes in the hat (8) with the small threaded holes in the hub (4). Install three flat head socket head screws (11) through the small holes in the hat (8) and torque to 85 **in-lb**. Check to be sure the hat seats squarely against the hub face.

- NOTE:** Please reference the caution statement at the beginning of the assembly instructions. The caliper mount brackets (16) should be installed first with clean, dry threads on the mounting bolts (17). Place sleeve (19) into the holes on the radial mount caliper bracket (16). Install the radial mount caliper bracket (16) on the backside on the flat caliper bracket (1) by sliding bolt (17) through washer (18) and through the bracket holes. Place spacer (20) and shim washer (21) between the two brackets and screw bolt (17) into insert nut on the flat caliper bracket (1). Finger tighten bolt (17). Use one thin shim (21) between the two brackets (1 and 16) during initial trial fitting.

- Lubricate caliper mounting studs (23) and nuts (27) with lightweight oil. Slide spacer (24) over caliper bracket mounting studs (23), then install two shim washers (25) over each pre-installed stud (23) on the radial mount bracket (16). Slide the caliper (22) in place over the studs and rotor, then install the washer (26) and lock nut (27) to hold the caliper in place. The caliper bleed screws should be pointing up.

- View the rotor (7) through the top opening of the caliper (22). The rotor (7) should be aligned in the center of the caliper (22). If not, adjust the radial mount caliper bracket (16) by using shims (21 and/or 29) placed between the two brackets (1 and 16). Add as many shim washers (21 and/or 29) as necessary to achieve the correct alignment. Always use the same amount of shims on both the top and bottom radial mount caliper mounting bolts (17). Finger tighten and recheck alignment, adjust as necessary. Apply red *Loctite*® 271 to bolt threads (17) and torque to 47 ft-lb.

- Remove the caliper center bridge pad retainer bolt, nut, and tube from the caliper. Slide the brake pads (28) into place. They should install easily without interference. Check that the outside radius of the brake pad is flush with the outside diameter of the rotor face. Add or subtract shims (25) between the caliper and mount bracket to gain the proper alignment. Reinstall the caliper and torque the caliper nuts (27) to 30-35 ft-lb. Reinstall the center bridge pad retainer tube, bolt, and locknut. The locknut should be snug without play in the bolt or tube. Be cautious not to over tighten.

- Repeat the above steps for the other wheel.

- NOTE:** OEM rubber brake hoses generally cannot be adapted to Wilwood calipers. The caliper inlet fitting is a 1/8-27 NPT. The preferred method is to use steel adapter fittings at the caliper, either straight, 45 or 90 degree and enough steel braided line to allow for full suspension travel and turning radius, lock to lock. **Carefully route lines to prevent contact with moving suspension, brake or wheel components.** Wilwood hose kits are designed for use in many different vehicle applications and it is the installer's responsibility to properly route and ensure adequate clearance and retention for brake hose components. Wilwood offers a hose kit, P/N 220-10509, which includes hoses, fittings, etc., all in one package for this application.

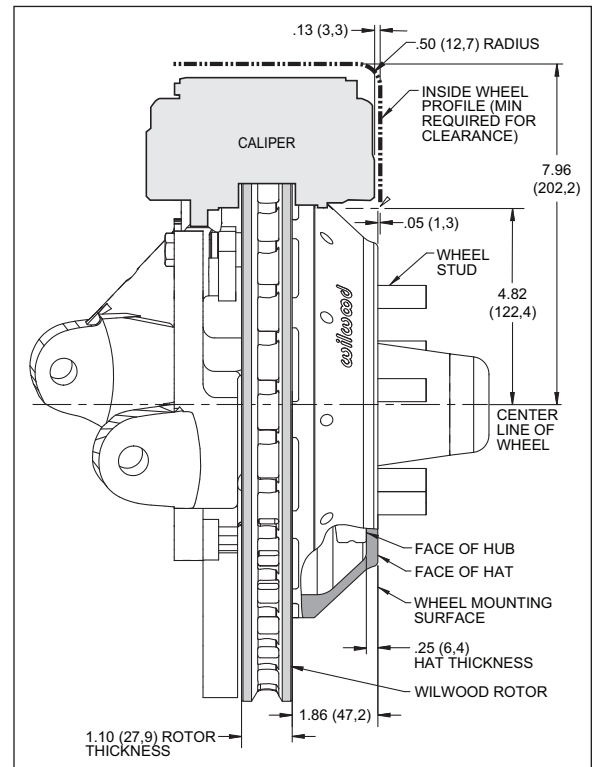

Figure 3. Wheel Clearance Diagram

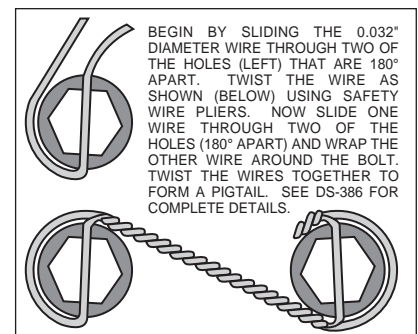

Figure 4. Safety Wire Diagram

## Assembly Instructions (Continued)

- Specified brake hose kits may not work with all Years, Makes and Models of vehicle that this brake kit is applicable to, due to possible OEM manufacturing changes during a production vehicle's life. It is the installer's responsibility to ensure that all fittings and hoses are the correct size and length, to ensure proper sealing and that they will not be subject to crimping, strain and abrasion from vibration or interference with suspension components, brake rotor or wheel.
- In absence of specific instructions for brake line routing, the installer must use his best professional judgment on correct routing and retention of lines to ensure safe operation. Test vehicle brake system per the 'minimum test' procedure stated within this document before driving. After road testing, inspect for leaks and interference. Initially after install and testing, perform frequent checks of the vehicle brake system and lines before driving, to confirm that there is no undue wear or interference not apparent from the initial test. Afterwards, perform periodic inspections for function, leaks and wear in a interval relative to the usage of vehicle.
- Bleed the brake system. Reference the general information and recommendations below for proper bleeding instructions.

## Balancing the Brake Bias on 4 Wheel Disc Vehicles

### •OE Style or Single Mount Race Pedal with Tandem Outlet Master Cylinder:

Front to rear caliper piston sizes, rotor diameters, and pad compounds must be initially configured to provide the correct range of vehicle bias when using a single bore / tandem outlet master cylinder. If excessive rear brake bias is experienced, an inline adjustable proportioning valve can be used to decrease the rear line pressure to help bring the vehicle into balance. If excessive front brake bias is experienced, first consideration should be given to increasing the rear brake bias to bring the vehicle into overall balance.

### •Race Pedal with Dual Master Cylinders and Balance Bar:

Master cylinders must be sized to match the calipers and allow the pedal balance bar to operate near the center of its travel. If it is not possible to fine tune the bias within the adjustable range of the balance bar, then consideration must be given to changing a master cylinder bore size or some other aspect of the brake system to bring the car into balance. Larger bore master cylinders will generate less pressure while decreasing pedal travel. Smaller bores master cylinders will generate higher line pressures with an increase in pedal travel.

## Additional Information and Recommendations

- Fill and bleed the new system with Wilwood Hi-Temp° 570 grade fluid or higher. For severe braking or sustained high heat operation, use Wilwood EXP 600 Plus Racing Brake Fluid. Used fluid must be completely flushed from the system to prevent contamination.  
**NOTE:** Silicone DOT 5 brake fluid is **NOT** recommended.
- To properly bleed the brake system, begin with the caliper farthest from the master cylinder. Bleed the outboard bleed screw first, then the inboard. Repeat the procedure until all calipers in the system are bled, ending with the caliper closest to the master cylinder.  
**NOTE:** When using a new master cylinder, it is important to bench bleed the master cylinder first.
- If the master cylinder is mounted lower than the disc brake calipers, some fluid flowback to the master cylinder reservoir may occur, creating a vacuum effect that retracts the caliper pistons into the housing. This will cause the pedal to go to the floor on the first stroke until it has "pumped up" and moved all the pistons out against the pad again. A Wilwood in-line two pound residual pressure valve, installed near the master cylinder will stop the fluid flowback and keep the pedal firm and responsive.
- Test the brake pedal. It should be firm, not spongy and stop at least 1 inch from the floor under heavy load.  
If the brake pedal is spongy, bleed the system again.  
  
If the brake pedal is initially firm, but then sinks to the floor, check the system for fluid leaks. Correct the leaks (if applicable) and then bleed the system again.  
  
If the brake pedal goes to the floor and continued bleeding of the system does not correct the problem, a master cylinder with increased capacity (larger bore diameter) will be required. Wilwood offers various lightweight master cylinders with large fluid displacement capacities.
- NOTE:** With the installation of after market disc brakes, the wheel track may change depending on the application. Check your wheel offset before final assembly.
- On some models of disc brake spindles there are "ears" where the OEM calipers were mounted and these "ears" interfere with the assembly of the Wilwood disc brake kit. If it becomes necessary to remove these "ears", remove as little as possible being careful not to cut away any of the mounting holes that may be required to bolt on the caliper mounting bracket.
- If after following the instructions, you still have difficulty in assembling or bleeding your Wilwood disc brakes, consult your local chassis builder, or retailer where the kit was purchased for further assistance.

## Brake Testing and Pad Bedding

### **WARNING • DO NOT DRIVE ON UNTESTED BRAKES BRAKES MUST BE TESTED AFTER INSTALLATION OR MAINTENANCE MINIMUM TEST PROCEDURE**

- Make sure pedal is firm: Hold firm pressure on pedal for several minutes, it should remain in position without sinking. If pedal sinks toward floor, check system for fluid leaks. DO NOT drive vehicle if pedal does not stay firm or can be pushed to the floor with normal pressure.
- At very low speed (2-5 mph) apply brakes hard several times while turning steering from full left to full right, repeat several times. Remove the wheels and check that components are not touching, rubbing, or leaking.
- Carefully examine all brake components, brake lines, and fittings for leaks and interference.
- Make sure there is no interference with wheels or suspension components.
- Drive vehicle at low speed (15-20 mph) making moderate and hard stops. Brakes should feel normal and positive. Again check for leaks and interference.
- Always test vehicle in a safe place where there is no danger to (or from) other people or vehicles.
- Always wear seat belts and make use of all safety equipment.

#### **PAD BEDDING PROCEDURE:**

• Pump brakes at low speed to assure proper operation. On the race track, or other safe location, make a series of hard stops until some brake fade is experienced. Allow brakes to cool while driving at moderate speed to avoid use of the brakes. This process will properly burnish the brake pads, offering maximum performance.

### **Associated Components**

<b><u>PART NO.</u></b>	<b><u>DESCRIPTION</u></b>
260-1874	Wilwood Residual Pressure Valve (2 lb for disc brakes)
260-1876	Wilwood Residual Pressure Valve (10 lb for drum brakes)
260-8419	Wilwood Proportioning Valve
290-0632	Wilwood Racing Brake Fluid (Hi-Temp° 570) (12 oz)
290-6209	Wilwood Racing Brake Fluid (EXP 600 Plus) (16.9 oz)
340-1285	Wilwood Floor Mount Brake Pedal (with balance bar)
340-1287	Wilwood Swing Mount Brake Pedal (with balance bar)
260-6764	Wilwood 3/4 inch High Volume Aluminum Master Cylinder
260-6765	Wilwood 7/8 inch High Volume Aluminum Master Cylinder
260-6766	Wilwood 1 inch High Volume Aluminum Master Cylinder
260-4893	1-1/16 inch Tandem Master Cylinder (aluminum housing)
250-2406	Mounting Bracket Kit (tandem master cylinder)
260-8555	Wilwood 1 inch Aluminum Tandem Chamber Master Cylinder
260-8556	Wilwood 1-1/8 inch Aluminum Tandem Chamber Master Cylinder
350-2038	1971 - 1973 Pinto Rack and Pinion (new, not rebuilt)
270-2016	Quick Release Steering Hub (3/4 inch shaft)
270-2017	Quick Release Steering Hub (5/8 inch shaft)
220-7056	Flexline Kit, Universal, 14 Inch, Domestic
220-7699	Flexline Kit, Universal, 16 Inch, Domestic
220-8307	Flexline Kit, Universal, 18 Inch, Domestic