



**Weiland® Gen. 3 Hemi, Mid-Sump Oil Pan
5050WND & 5051WND
Installation Instructions**

Thank you for making WEIAND your choice for high-performance fabricated oil pans. Proper installation and maintenance will ensure long life and maximum performance from your WEIAND products.

APPLICATIONS:

- Retro-fit vehicles
 - Mopar A-Body
 - Mopar B-Body
 - Mopar C-Body
 - Mopar E-Body
- Engine
 - Part # 5050WND – Hemi, Gen. 3 without VVT (includes proper pickup tube for this application)
 - Part # 5051WND – Hemi, Gen. 3 with VVT (includes proper pickup tube for this application)

OIL CAPACITY (APPROXIMATE):

- Sump Oil Capacity - 6 Quarts
- Total Oil Capacity with OEM oil filter - 6.5 Quarts

PARTS INCLUDED:

- Oil Pan
- Drain Plug
- M6 Flanged Hex Head Pan Mounting Bolts (X 21)

PARTS NOT INCLUDED, BUT REQUIRED:

- Dipstick - This pan works with all Gen. 3 OE and most aftermarket dipsticks intended for OE rear sump (truck) pans and aftermarket mid-sump pans. **It does not work with any dipsticks intended for OE front sump (Car) pans.**
- OEM MOPAR Windage Tray/Gasket Assembly Specific for you engine.

RECOMMENDED TOOLS:

Torque Wrench(s)	Metric Socket Set	1/4" or 1/2" Drive Ratchets
3/8" or 1/2" x 6" Extension	Jack Stands	Floor Jack
Box Cutter or Small Knife	RTV Gasket Cement or Sealer	Brake Cleaner or equivalent
Thread Cleaner Tool		

Please call tech service at **1-270-781-9741** or **1-866-464-6553** for additional information regarding this or any other WEIAND products.

BEFORE STARTING:

Place the vehicle in an adequately lit and ventilated location where the floor is solid and flat. DO NOT work on a hot engine. Heat causes metal to expand and makes the removal of fasteners more difficult. Please be sure to wear the proper safety equipment; eye goggles and gloves are recommended to ensure a safe installation. **(Read Instructions prior to installation).**

Removal of the OEM Oil Pan

1. Unbolt and remove the engine oil dipstick located between bolts 6 & 10.
2. Remove the M10 retaining bolts (horizontal 11, 12, 15, 18 and vertical 20, 21, 22, 23) from the rear of the oil pan to the transmission and the remaining M6 bolts and remove the OEM oil pan.

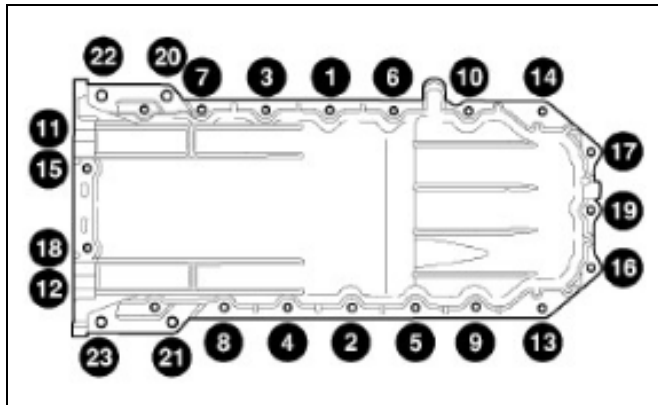

Note: Do not pry on the oil pan or oil pan gasket. The oil pan gasket is integral to the engine windage tray and does not come out with the oil pan.

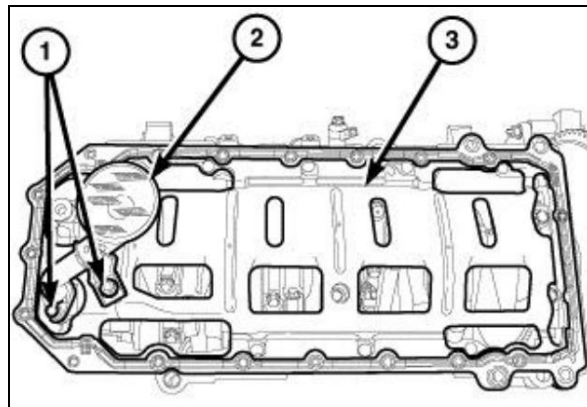

3. Remove the oil pump pickup tube retaining bolt and nut (1). **Note: Nut will only be on the 6.4L engine.**
4. Remove the oil pump pickup tube (2).
5. Remove and discard the oil pan gasket/windage tray (3).
6. Clean the oil pan gasket mating surface of the block and oil pan.
7. Remove the oil dip stick plug (1) from the engine using a punch.

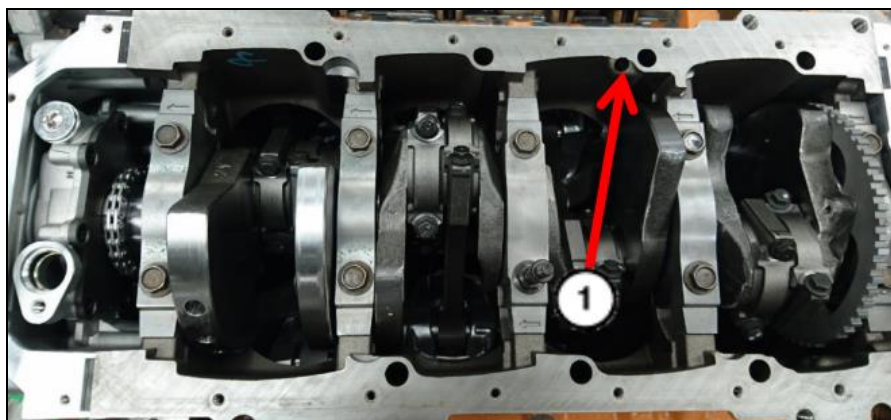

8. A main stud will need to be relocated to accept the new oil pick up tube.
- a. **6.4L** – Remove the main cap double ended stud (9) and the middle main cap bolt (1).
 - b. **5.7L** – Remove the middle main cap bolt (1)

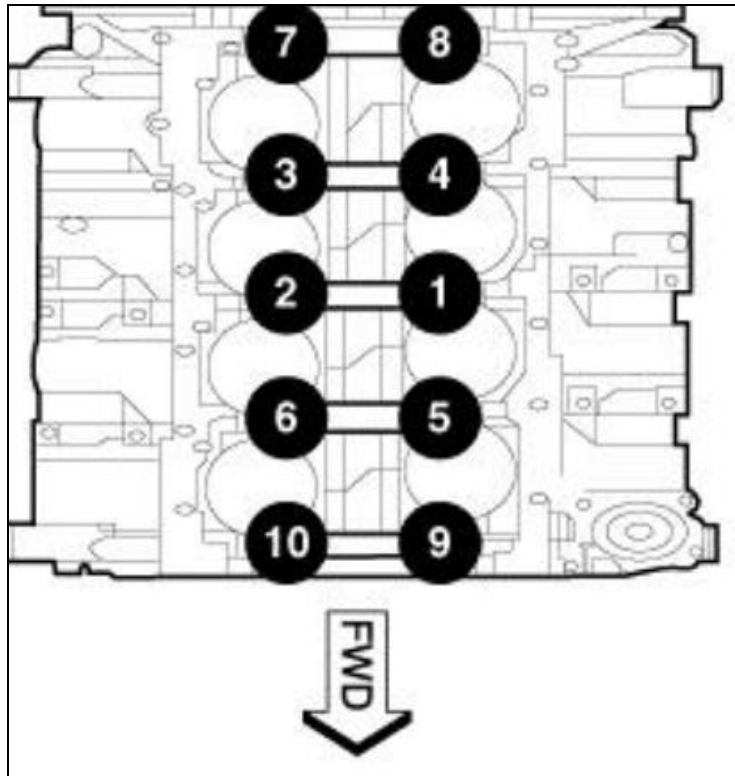

- c. **6.4L** - Reinstall the main cap bolt removed from the middle of the first location (1). Install a new main cap double ended stud to the middle location (2). Torque to 28 N-m (21 ft./lbs.) then rotate the main cap bolt and double ended stud an additional 90 degree turn.
- d. **5.7L** – Install a new main cap double ended stud to the middle location (2). Torque to 28 N-m (21 ft./lbs.) then rotate the main cap double ended stud an additional 90 degree turn.

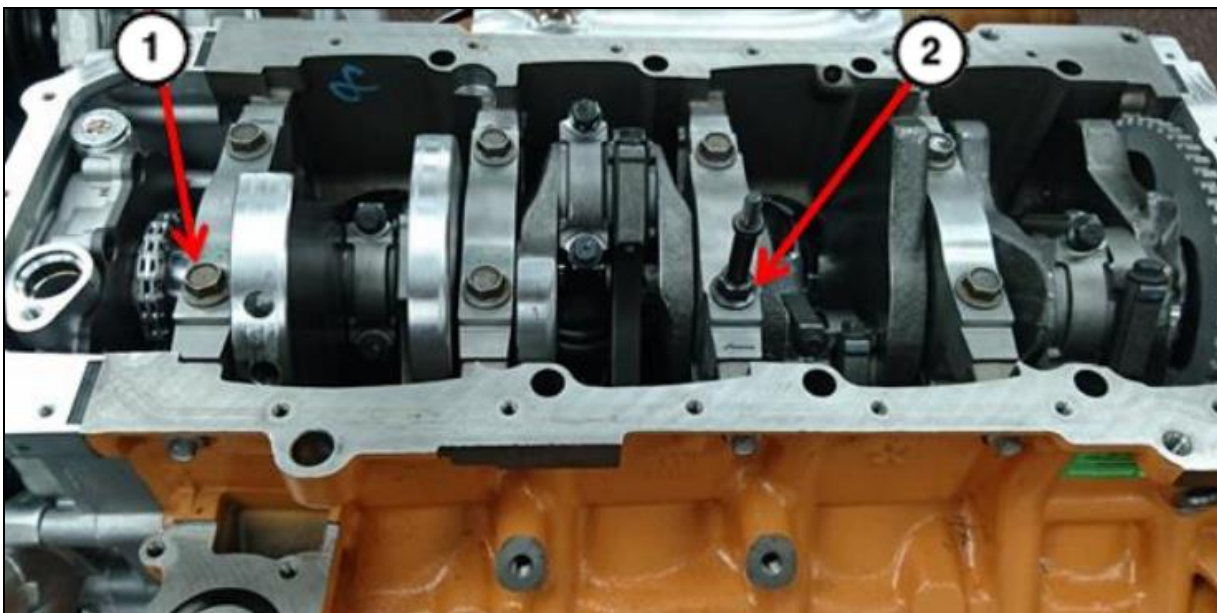

Installation of the Weiand Mid-Sump Oil Pan

1. Windage tray/gasket preparation:

- e. A brand-new, unused OEM oil pan gasket with integral windage tray for your specific engine must be used. Reusing the original gasket which was removed in step 2, will result in oil leaks.
- f. Although all Gen. 3 Hemi windage trays should work, some may not have all the holes required for this mid-sump pan (see below). **Weiand recommends the following integral windage tray and gaskets:**

6.4L - 04893353AA
5.7L - 53021568AE

If this hole is in a different location than shown, one will need to be drilled to allow for the standoff to be moved here. It is recommended to use a step style bit for this operation.

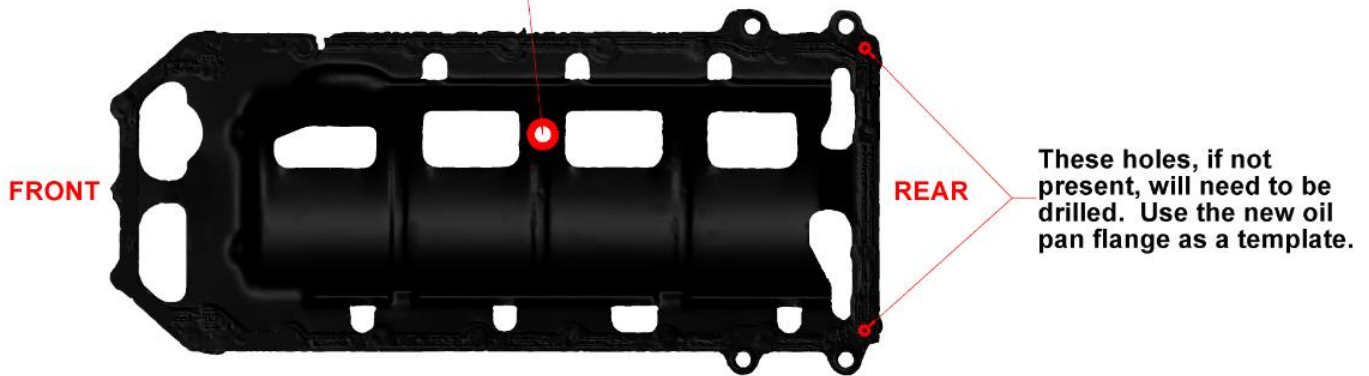

- 9. RTV must be applied to the (x4) joints shown below. These are the areas where the front cover, rear retainer, and oil pan gasket meet. The bead of RTV should cover the bottom of the gasket. This area is approximately 4.5 mm x 25 mm in each of the 4 joint locations.

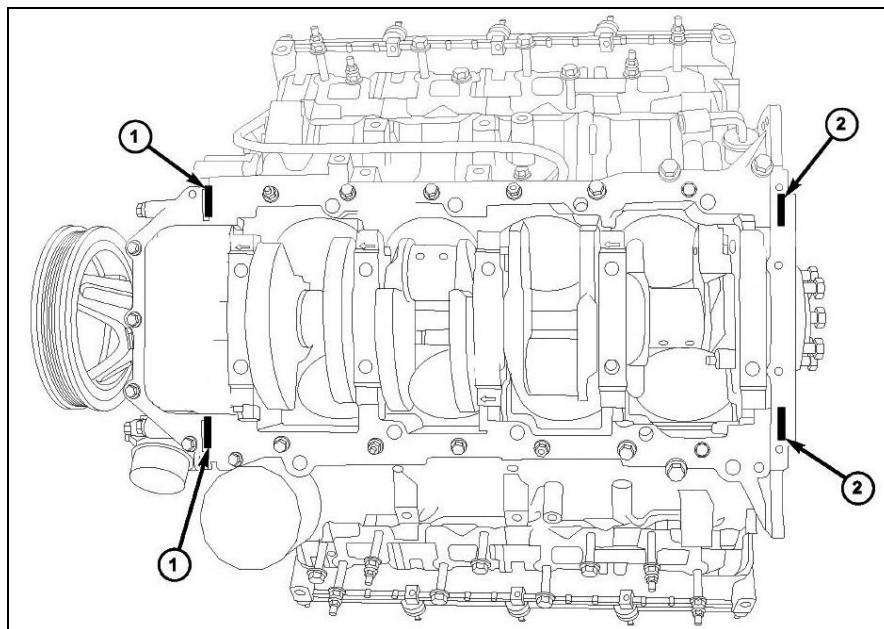

10. Position the windage tray to the engine block. Install the oil pump pickup in the oil pump housing per manufacturer's instruction. **IMPORTANT: Use O-ring included with the new pickup tube only.**

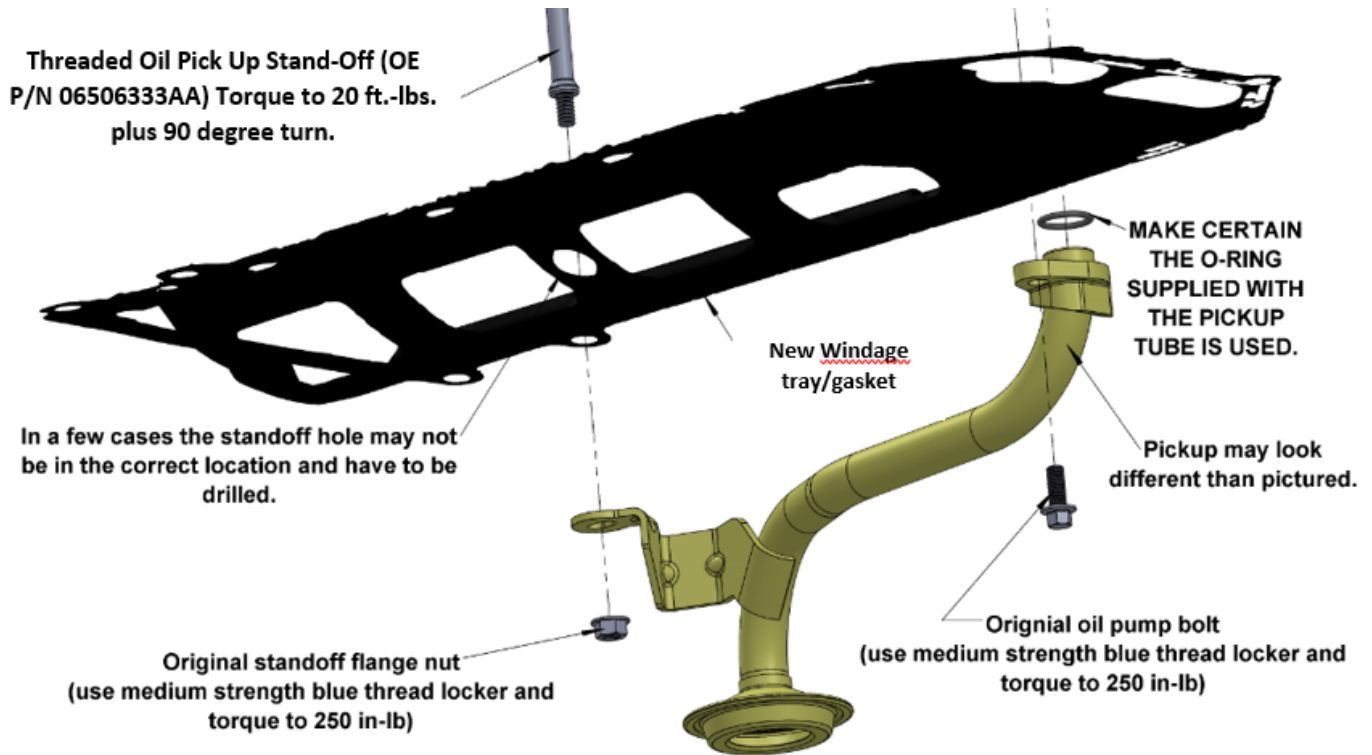

11. Position the pan onto the engine flange. Install all oil pan bolts by hand while ensuring the bolts thread in easily. Using a 10mm socket, follow the below sequence and tighten each of the M6 bolts, first to 106 in./lbs. **DO NOT OVERTIGHTEN THE PAN BOLTS!**

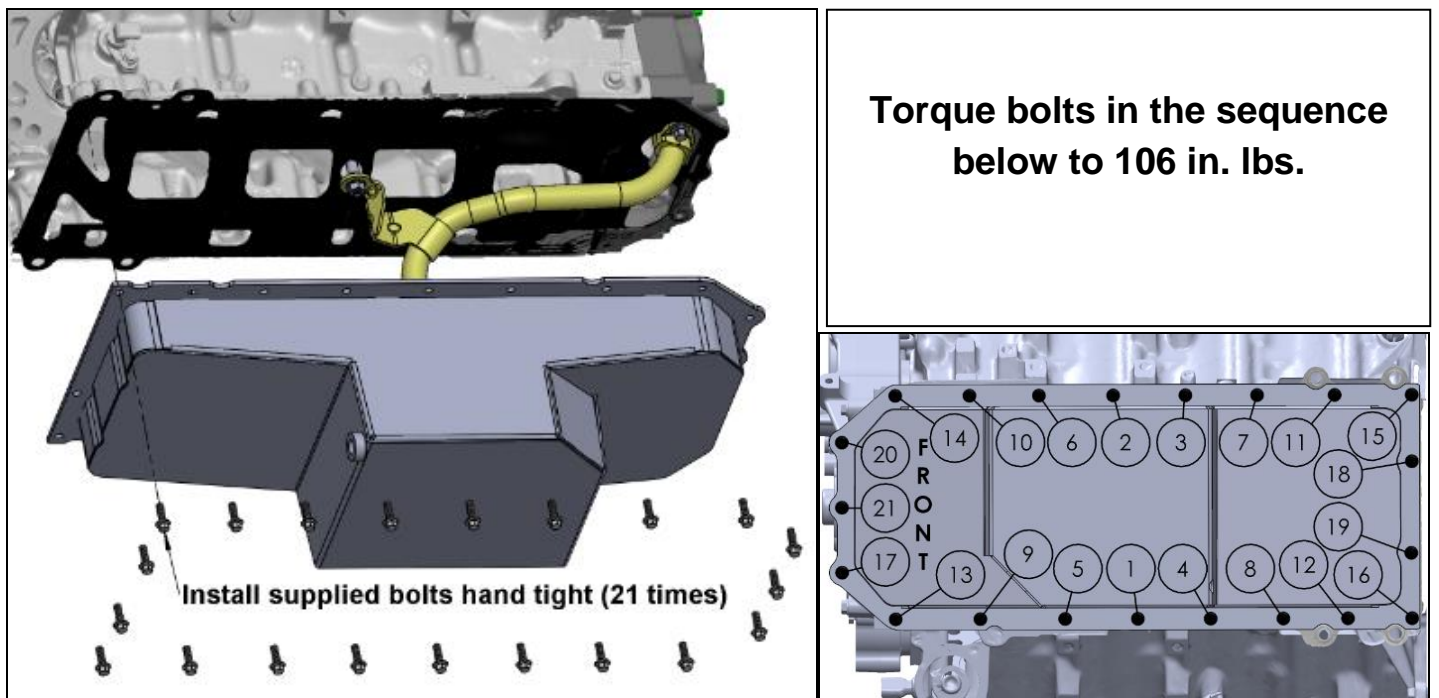

12. Install the supplied oil pan drain plug and tighten to 18 ft./lbs.

13. Install the dipstick tube fully to the engine

14. Install the dipstick.
15. Reinstall any accessories previously removed during the oil pan installation. Make sure all connections are secure.
16. Fill engine with oil and check proper fill level via dipstick.
17. Start the engine and bring up to operating temperature. Check for leaks. Turn engine off and allow to cool.
18. Re-check oil level.
19. Give vehicle a test drive, checking carefully for any new noises or leaks.
20. After several days of driving, check connections and re-tighten all bolts.

Technical Support: **1-866-464-6553** or **1-270-781-9741**. For online help, please go to **www.holley.com**.

© 2020 WEIAND. All rights reserved. Tous Droits Réservés.

199R12078

Revision Date: 12-3-20