

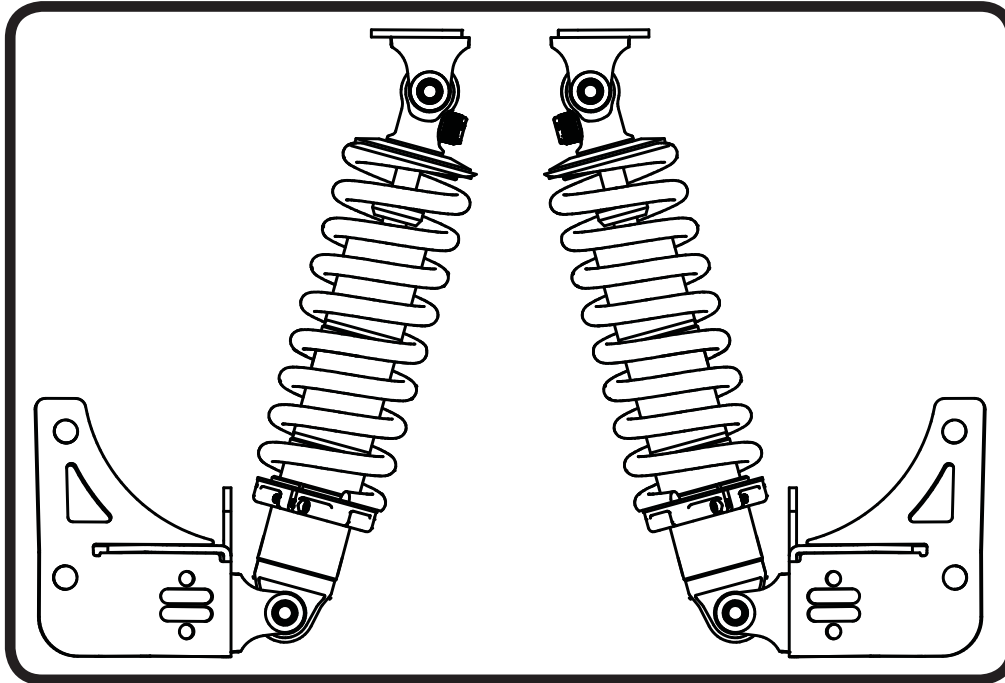

**Part # 11226110 - 1964-1972 GM A-Body Rear CoilOver**

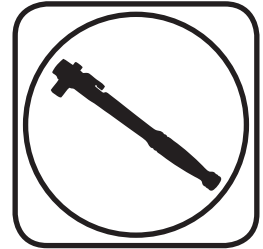

Recommended Tools



## 64-72 A-Body HQ Series Rear CoilOver Installation Instructions

### Table of contents

Page 2.....	Included components
Page 3.....	Hardware List and Getting Started
Page 4.....	CoilOver Assembly & installation
Page 5.....	CoilOver Installation
Page 6.....	CoilOver Installation & Setting Spring Height
Page 7.....	Shock Adjustment





### Major Components .....In the box

Item #	Part #	Description	QTY
1	24159999	5.2" Stroke HQ Series Shock	2
2	59120225	12" 225lb CoilSpring	2
3	70010828	Delrin CoilSpring Washer	4
4	90002222	CoilSpring Retainer Kit	2
5	90002024	Shock Eyelet	2
6	90001994	5/8" ID Bearing (installed in shock and eyelet)	4
7	90001995	Bearing Snap Ring (installed in shock and eyelet)	8
8	90002043	1/2" ID Upper Bearing Spacers	8
9	90002327	Upper Mount	2
10	90002224	Driver Lower Mount	1
10	90002223	Passenger Lower Mount (not shown)	1

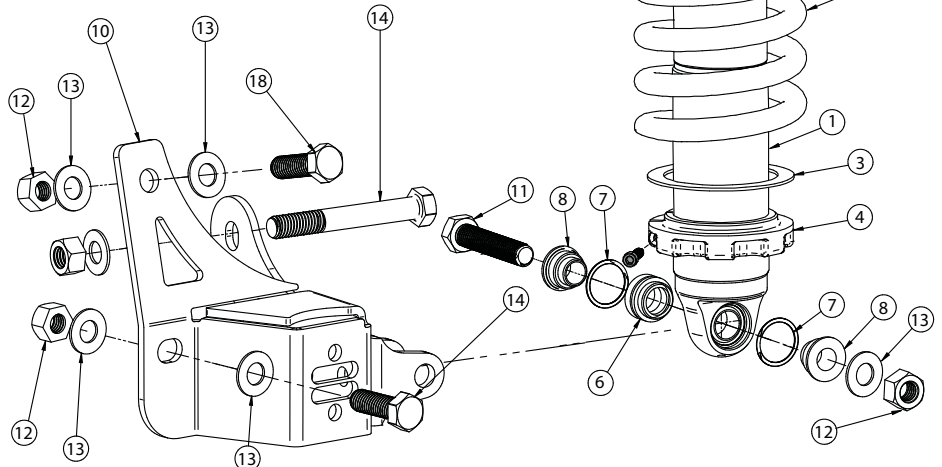
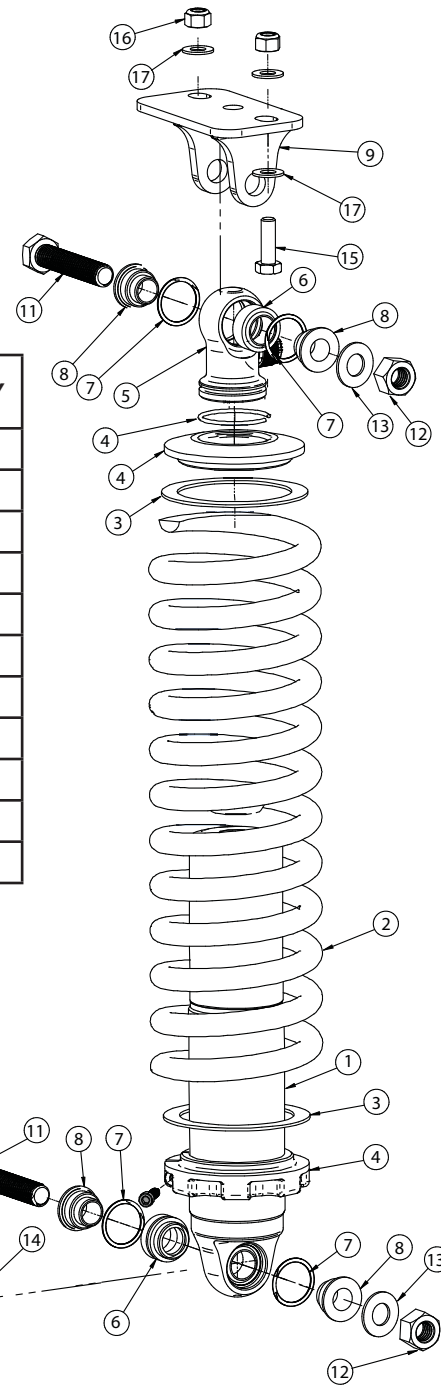



### Hardware List .....In the box

Item #	QTY	Part Number	Description	Location
11	4	99501011	1/2"-20 x 2 1/2" Hex Bolt	ShockWave to Mounts
12	10	99502002	1/2"-20 Nylok Nut	ShockWave to Mounts, Lower Bar Bolt
13	14	99503014	1/2" SAE Flat Washer	ShockWave to Mounts, Lower Bar Bolt
14	2	99501015	1/2"-20 x 3 3/4" Hex Bolt	Lower Bar Bolt
15	4	99311011	5/16"-18 x 1 1/4" Hex Bolt	Upper Mounts to Frame
16	4	99312002	5/16"-18 Nylok Nut	Upper Mounts to Frame
17	8	99313001	5/16" SAE Flat Washer	Upper Mounts to Frame
18	4	99501008	1/2"-20 x 1 1/2" Hex Bolt	Lower Mounts to Differential

### Getting Started.....

Congratulations on your purchase of the Ridetech Rear CoilOver System. This system has been designed to give your car excellent handling along with a lifetime of enjoyment. One of the key features of this system is the adjustability. With the CoilOver system you have an adjustable shock along with the height adjustment of the CoilOver.

### Disassembly

1. Raise and safely support the vehicle by the frame rails.
2. Using a jack, slightly raise the axle approximately 1". Remove the shock absorbers.
3. Lower the axle down enough to remove the coil springs.
4. The exhaust tail pipes may need to be removed and/or modified for ShockWave installation.

**NOTE:** Keep in mind the spring has pressure on it until you let the rear differential down to remove the springs.



### Coilover Assembly



First using the supplied lower adjuster nut (90002222) thread the nut onto the shock from the bottom side as seen in figure 1



Next install delrin washers then coil spring over the top of the shock as seen in figure 2



Before the upper spring mount can be installed screw the adjuster knob on the upper eye mount to the firmest setting (clockwise) as seen in figure 3.



Slide the Derlin washer over the spring, Next slide the upper spring mount (90002222) over eyelet as seen in figure 4.



Install upper spring mount retainer clip (90002057) into the groove on the upper eyelet as seen in figure 5. Then reinstall adjuster to complete assembly.

### CoilOver Installation



5. Remove the lower trailing arm mounting bolt. (Do one side at a time to keep the axle from rotating). Install the longer  $\frac{1}{2}$ " x  $3 \frac{3}{4}$ " bolt through the lower trailing arm from the outside in. Install the lower bracket over the bolt and secure with a  $\frac{1}{2}$ " Nylok nut and flat washer. Snug the Hardware, but do NOT fully tighten at this time.





### CoilOver Installation



6. The lower bolt hole in the back of the bracket will align with the factory shock stud hole. Use a  $\frac{1}{2}$ " x  $1\frac{1}{2}$ " bolt, Nylok nut and flat washers. The upper hole must be drilled with a  $\frac{1}{2}$ " bit. The edge of the bracket should be parallel to the axle bracket. Use an centering punch and  $\frac{1}{8}$ " bit to drill a pilot hole. A  $\frac{1}{2}$ " x  $1\frac{1}{2}$ " bolt, Nylok nut and flat washers will be used here as well. Torque all hardware to 75 ftlbs.



7. Fasten the new upper shock bracket into the factory shock location using the  $\frac{5}{16}$ " x  $1\frac{1}{4}$ " bolts, flat washers and Nylok nuts supplied. Torque to 17 ftlbs.

**Note:** Position the bracket to offset the shock toward the center of the car.

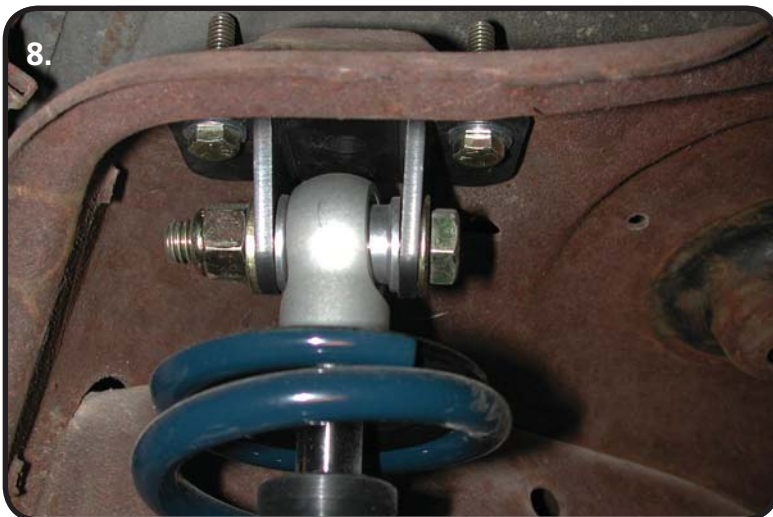

8. Fasten the CoilOver to the upper bracket using a  $\frac{1}{2}$ " x  $2\frac{1}{2}$ " bolt,  $\frac{1}{2}$ " flat washer, and Nylok nut.  $\frac{1}{2}$ " I.D. aluminum spacers must be installed on each side of the bearing. Torque to 75 ftlbs.



### CoilOver Installation



**9.** Fasten the CoilOver to the lower bracket using a 1/2" x 2 1/2" bolt, 1/2" flat washer, and Nylok nut. 1/2" I.D. aluminum spacers must be installed on each side of the bearing. Torque to 75 ftlbs.

**11.** Ride height on this CoilOver is 14.5" from center eye to center eye.

### Setting Spring Height

#### Ride Height

We have designed most cars to have a ride height of about 1 1/2" lower than factory. To achieve the best ride quality & handling, the shock absorber needs to be at 40-60% overall travel when the car is at ride height. This will ensure that the shock will not bottom out or top out over even the largest bumps. Measuring the shock can be difficult, especially on some front suspensions. Measuring overall wheel travel is just as effective and can be much easier. Most cars will have 4-6" of overall wheel travel. One easy way to determine where you are at in wheel travel is to take a measurement from the fender lip (center of the wheel) to the ground. Then lift the car by the frame until the wheel is just touching the ground, re-measure. This will indicate how far you are from full extension of the shock. A minimum of 1.5" of extension travel (at the wheel) is needed to ensure that the shock does not top out. If you are more than 3" from full extension of the shock then you are in danger of bottoming out the shock absorber.

#### Adjusting Spring Height

When assembling the CoilOver, screw the spring retainer tight up to the spring (0 preload). After entire weight of car is on the wheels, jounce the suspension and roll the car forward and backward to alleviate suspension bind.

- If the car is too high w/ 0 preload then a smaller rate spring is required. Although threading the spring retainer down would lower the car, this could allow the spring to fall out of its seat when lifting the car by the frame.
- If the car is too low w/ 0 preload, then preload can then be added by threading the spring retainer up to achieve ride height. On 2.6" - 4" stroke shocks, up to 1.5" of preload is acceptable. On 5-7" stroke shocks, up to 2.5" of preload is acceptable. If more preload is needed to achieve ride height a stiffer spring rate is required. Too much preload may lead to coil bind, causing ride quality to suffer.



### Shock Adjustment

#### Shock adjustment 101- Single Adjustable

##### Rebound Adjustment:

How to adjust your new shocks.

The rebound adjustment knob is located on the top of the shock absorber protruding from the eyelet.

You must first begin at the ZERO setting, then set the shock to a soft setting of 20.



-Begin with the shocks adjusted to the ZERO rebound position (full stiff). Do this by rotating the rebound adjuster knob clockwise until it stops.



-Now turn the rebound adjuster knob counter clock wise 20 clicks. This sets the shock at 20. (settings 21-24 are typically too soft for street use).

##### Take the vehicle for a test drive.



-if you are satisfied with the ride quality, do not do anything, you are set!



-if the ride quality is too soft increase the damping effect by rotating the rebound knob clock wise 3 clicks. **CONTINUE ON NEXT PAGE.**

##### Take the vehicle for another test drive.



-if the vehicle is too soft increase the damping effect by rotating the rebound knob clock wise 3 additional clicks.



-If the vehicle is too stiff rotate the rebound adjustment knob counter clock wise 2 clicks and you are set!

Take the vehicle for another test drive and repeat the above steps until the ride quality is satisfactory.

##### Note:

**One end of the vehicle will likely reach the desired setting before the other end. If this happens stop adjusting the satisfied end and keep adjusting the unsatisfied end until the overall ride quality is satisfactory.**

### STILL HAVE QUESTIONS?

#### Tech line hours

Monday - Friday

8AM - 6PM (EST) ..... 812-482-2932