



Part # 11013699 - 1955-1957 GM B-Body Front Upper StrongArms



Recommended Tools



1955-1957 GM B-Body Upper StrongArms Installation Instructions

Table of contents

- Page 2..... Upper Control Arm Components
- Page 3..... Getting Started & Installation
- Page 4..... Installing Spindle and Alignment





Upper Control Arm ComponentsIn the box

Item #	Part Number	Description	QTY
1	90001292	Driver Upper Control Arm (Shown)	1
1	90001293	Passenger Upper Control Arm	1
2	90003041 kit	Tall Upper Ball Joint Kit	2
3	90002695 kit	Cross Shaft Kit - contains 2 cross shafts	1
4	70014457	Delrin Bushing	4
5	90001288	Delrin Bushing Inner Sleeve	4
6	99373001	Outer Washer - Cross Shaft	4
7	99373005	3/8" Split Lock Washer -Cross Shaft	4
8	99371015	3/8"-24 x 1 1/2" Hex Bolt - Cross Shaft	4

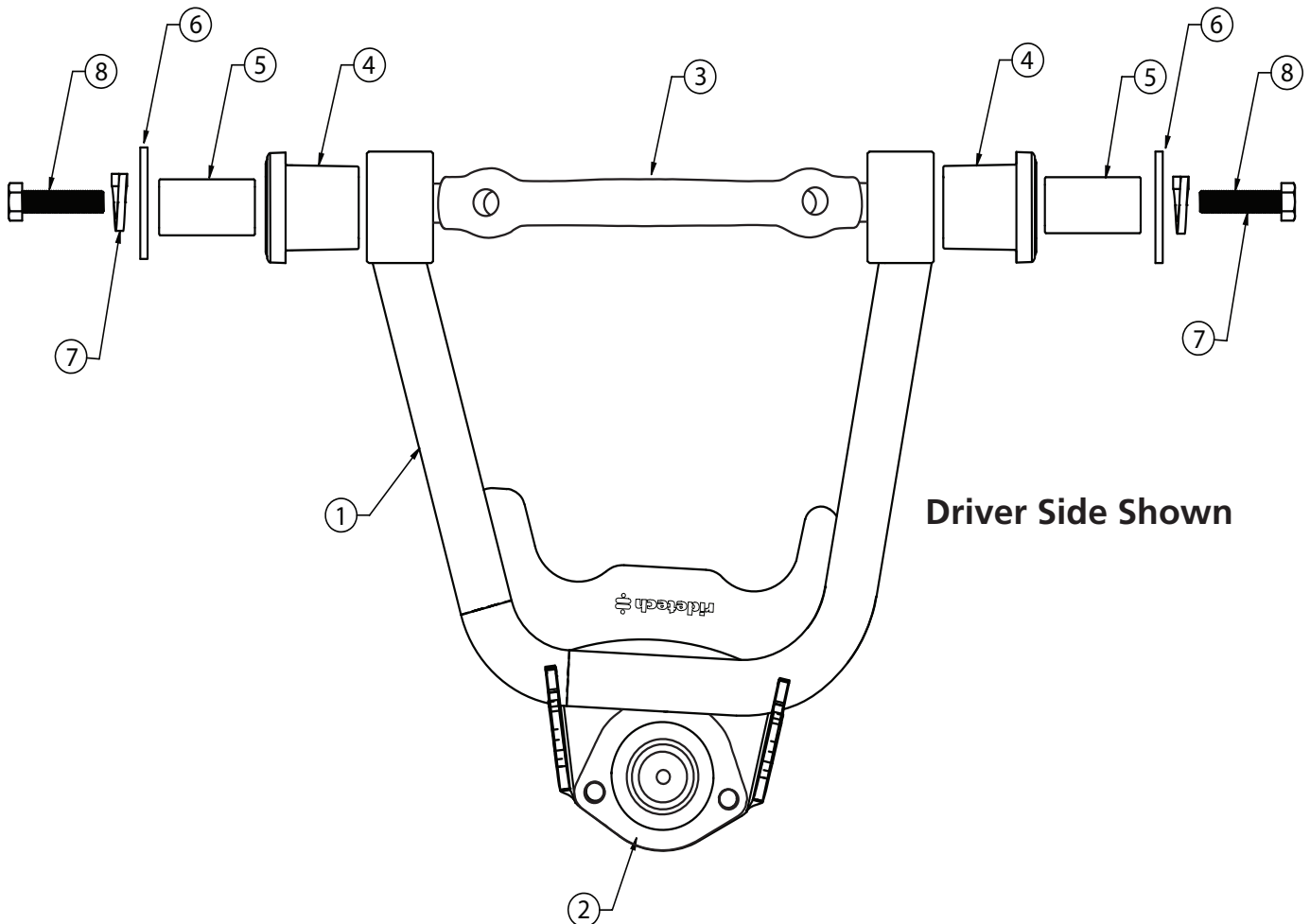



Getting Started.....

Congratulations on your purchase of the Ridetech Tri5 StrongArms. These StrongArms have been designed to give your Tri5 excellent handling along with a lifetime of enjoyment. Some of the key features of the StrongArms: Ball joint angles have been optimized for the lowered ride height, Delrin bushings are used to eliminate bushing deflection along with providing free suspension movement through the entire travel. The Delrin bushings are made from a material that is self lubricating so no grease zerks are needed.

When assembling the Control Arms tighten the cross shaft bolts enough to create drag on the delrin bushings, the arm should still move through its travel by hand.

Installation

1. Remove the upper control arms from the car. Keep the shims separate so that you can put them back in the location they were removed from. If you are replacing the lower control arms and spindle, remove them too. Refer to a Factory Service Manual for the proper method.

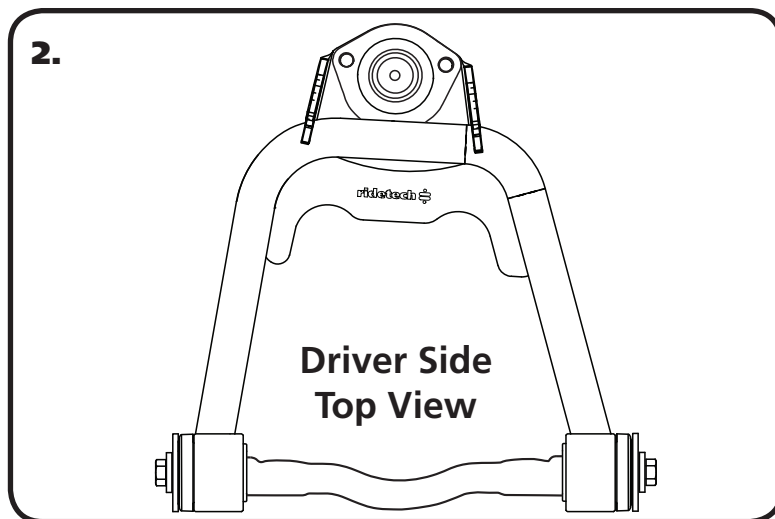

2. The Upper Control Arm is attached to the factory frame using factory hardware. The driver side arm is shown in **Figure "2"**. The Ball joint is located on the arm to the REAR of the car.



3. The Upper Control Arm is attaching the factory mount using factory hardware. Reinstall the shims in the location they were removed from. The passenger side arm is shown in **Figure "3"**.



Installing Spindle and Alignment

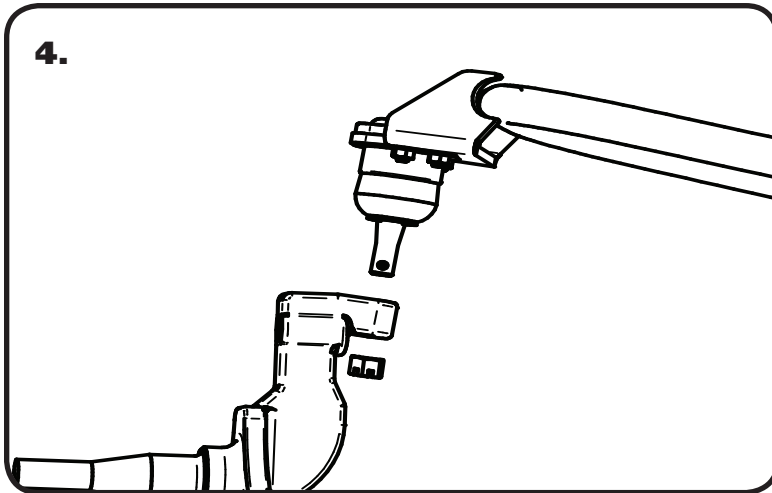

4. Attach the Spindle to the control arms. These control arms use a tall ball joint, the boot will NOT touch the spindle. This is normal.

Torque Specs:

Ball joint - 45 ftlbs and tighten to line up cotter pin.

Install the Cotter Pin after tightening the ball joint nut.

5. Tighten all fasteners.

When assembling the Control Arms tighten the cross shaft bolts enough to create drag on the delrin bushings, the arm should still move through its travel by hand.

Suggested Alignment Specs:

Camber:	Street: -.5 degrees
Caster:	Street: +3.0 to + 5.0 degrees
Toe:	Street: 1/16" to 1/8" toe in