

MSD INSTALLATION INSTRUCTIONS

PRO 600 CDI PN 8000

ONLINE PRODUCT REGISTRATION: Register your MSD product online. Registering your product will help if there is ever a warranty issue with your product and helps the MSD R&D team create new products that you ask for! Go to www.msperformance.com/registration.

Note : This product cannot be used with Solid Core spark plug wires.

Parts Included:

1 - PRO 600 CDI ECU	1 - Power Grid/Profiler Harness
1 - Coil Harness	1 - Parts Bag
1 - EFI Harness	

Required Items:

MSD CAM Sync Plugs - (for Power-Grid & Davis Profiler Installations)

1 - Ford 351C-460 CAM Sync Plug....PN 85211
1 - Chevy SB/BB CAM Sync Plug.....PN 85141
1 - Ford 289/302 CAM Sync Plug.....PN 85221
1 - Ford 351W Sync Plug.....PN 85061

Holley Cam Sync Kits

1 - BBC Standard cam height.....PN 556-114
1 - SBC Standard cam height.....PN 556-119
1 - BBC +.400 cam height.....PN 556-120
1 - BBC +.600/1.00" cam height..PN 556-121
1 - Universal cam sync kit.....PN 556-123

FEATURES

- Eight outputs of up to 680 mJ energy
- High-efficiency Alternating Current (AC) power delivery
- Over 50 Kilovolts output voltage when used with MSD suggested coils (See COIL SELECTION section on page 3)
- Spark duration of greater than 300 microseconds
- Continuous 600 mJ operation
- Six volts starting and running voltage (minimum 12V for 600 mJ output)
- Maximum Operating Voltage 22V
- Direct Plugin to Holley EFI systems
- Compatible with most EFI systems, including 5V or 12V drivers
- Plugin interface with MSD Power-Grid or Davis Profiler
- Reverse Battery Protection
- Protection against shorted or open coils, and over temperature
- Diagnostic LEDs
- On-the-fly Power Output selection wire
- Fits most coil-per-plug engines up to eight cylinders (Including four and six cylinders)



Figure 1. PRO 600 CDI ECU

The PRO 600 CDI is engineered and built for the most demanding racing applications. This ignition is capable of running continuously at a power level of up to 600 milli-Joules (mJ) inducing more than 300 microseconds of spark duration.

With a Power Boost wire, the ignition output can be changed on the fly between programmable lower energy (325 mJ by default) to higher programmable energy (600 mJ by default). The lower energy reduces the battery power requirements, lessening the stress on the ignition components. The ignition's use of Alternating Current (AC) energy transfer and an internal coil coupler, considerably improves the system's efficiency over Direct Current (DC) Ignitions. This increased efficiency translates to more energy at the spark gap combined with longer spark duration and cooler operating temperature of the ignition coils.

To further improve efficiency, unused spark energy is recycled back to the ignition capacitor reducing the power drawn from the battery. The PRO 600 CDI Ignition provides up to 20% additional spark gap energy and 40% increase in spark duration over other 600 mJ ignitions available in the market. Additionally, the ignition's high-efficiency design reduces power demand from the battery, which in turn reduces loads on the wires and connectors. As the PRO 600 CDI Ignition is designed for the most challenging applications, it is also capable of continuous full-power operation.

The PRO 600 CDI Ignition works with most coil per plug EFI systems with up to eight ignition outputs. The PRO 600 CDI Ignition can convert a Distributor ignition into a coil per plug system using the MSD Power-Grid or the Davis Profiler with the appropriate Cam sync plug to take the place of the distributor. Each of the eight channels has a dedicated Diagnostic LED to detect a possible fault and simplify troubleshooting. Input activity, Open Coil, Shorted Coil, and Open Coil secondary are detected on each of the channels

MOUNTING

The PRO 600 CDI Ignition can be mounted in the engine compartment away from direct exhaust or engine heat sources. While finding a proper location to mount the unit, ensure that the wires can reach their intended connections and the diagnostic LEDs are within view.

NOTE: To disconnect harness from the controller, use a small flat-blade screwdriver to lift the latch before pulling on the connector. See Figure 2.

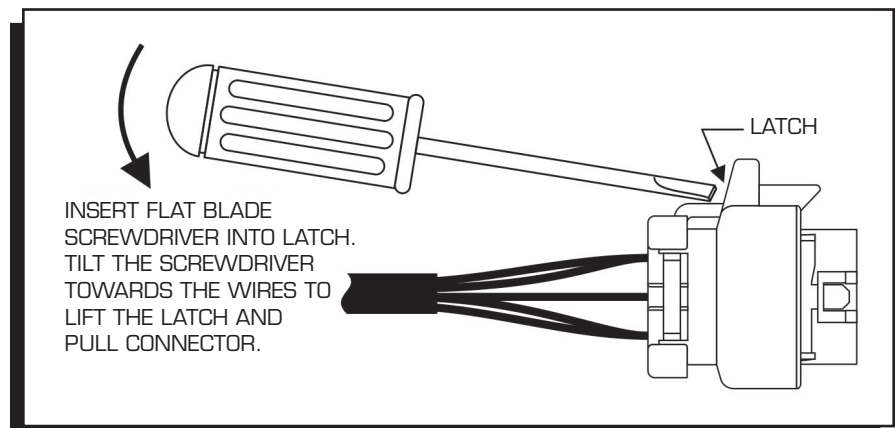

Figure 2. Removing connector from PRO 600 CDI

WIRING

Caution: The wire connections to the battery and the ignition coils are conducting high currents. Secure all connections to maintain good contact and ensure proper operation of the system. It is not recommended to extend the high current wires, although the wires can be shortened to fit the application.

Battery Connection

Connect the Red wire to Battery Positive and the Black wire to Battery negative using the included ring terminals.

Caution: Do not connect the Black wire to Battery Negative until all wiring installation is complete.

COIL SELECTION

Table 1 shows coil performance using the PRO 600 CDI ignition operating at a 600 mJ energy level. The PRO CDI is designed to work with the following ignition coils.

Ignition Coil	Maximum Secondary Voltage with 50pF Load	Peak Secondary Current	Spark Duration	Spark Gap Energy*
MSD 8232	52 KV	1.3 A	380 microseconds	195 mJ
MSD 8280	50 KV	1.7 A	345 microseconds	208 mJ
MSD8261/82613	51 KV	2.6 A	250 microseconds	230 mJ
MSD 8250	64KV	1.3A	320 microseconds	206 mJ

Table 1. Coil Performance

* For reference purpose only. Actual spark gap energy varies with different applications and operating conditions.

NOTE: Make sure that the ignition coils are securely installed in an appropriate location.

MSD PN 8232 - COIL WIRING

The MSD 8232 coil includes a pre-wired 3-pin connector. Each of the wires must be connected securely.

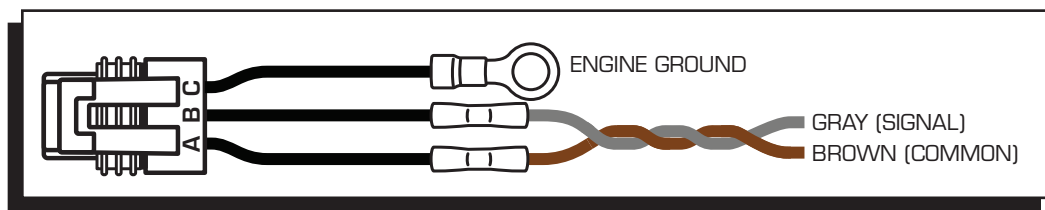

Figure 3. MSD 8232 Pigtail connector

PIN A: Connect to the Brown wire in the assigned wire pair A to H in the coil harness.

PIN B: Connect to the Gray wire in the assigned wire pair A to H in the coil harness

PIN C: Connect the Black wire with ring terminal to a good engine ground.

MSD PN 8280 - COIL WIRING

All wires must be securely connected to the coil.

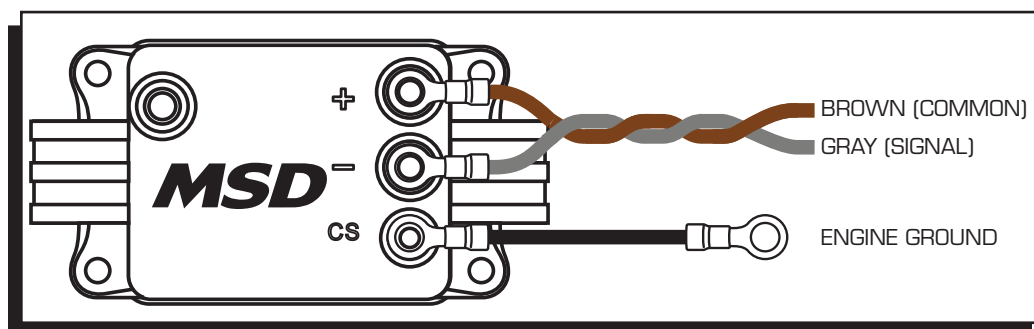

Figure 4. MSD 8280 Wiring

COIL (+): Connect to the Brown wire in the assigned wire pair, A to H in the coil harness.

COIL (-): Connect to the Gray wire in the assigned wire pair, A to H in the coil harness.

COIL (CS): Connect the Black wire with ring terminal to a good engine ground.

MSD 8261/82613 - COIL WIRING

All wires must be securely connected to the coil.

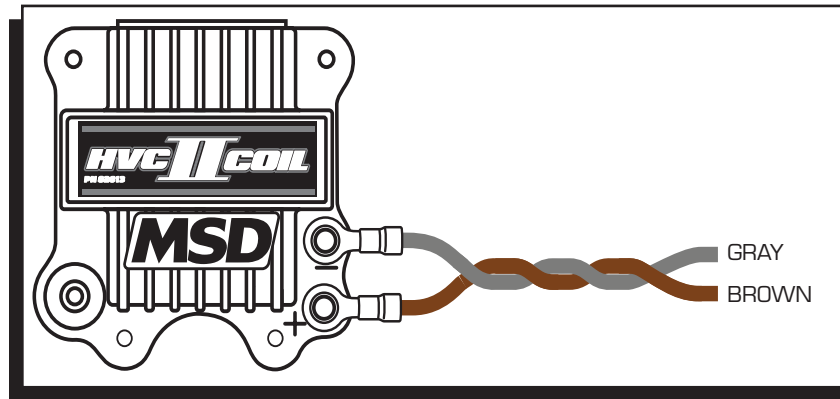

Figure 5. MSD 8261 / 82613 Wiring

COIL (+): Connect to the Brown wire in the assigned wire pair A to H in the coil harness.

COIL (-): Connect to the Gray wire in the assigned wire pair A to H in the coil harness.

EFI/LS APPLICATION CONNECTION

Figure 6. EFI/LS Input Connection

*Green wire not used when Holley EFI CAN is used.

Installation:

- Connect the 7-pin connector marked with the label DRIVER to the 7-pin connector designated to the Driver side on the EFI.
- Connect the 7-pin connector marked with the label PASSENGER to the 7-pin connector designated to the Passenger side on the EFI.

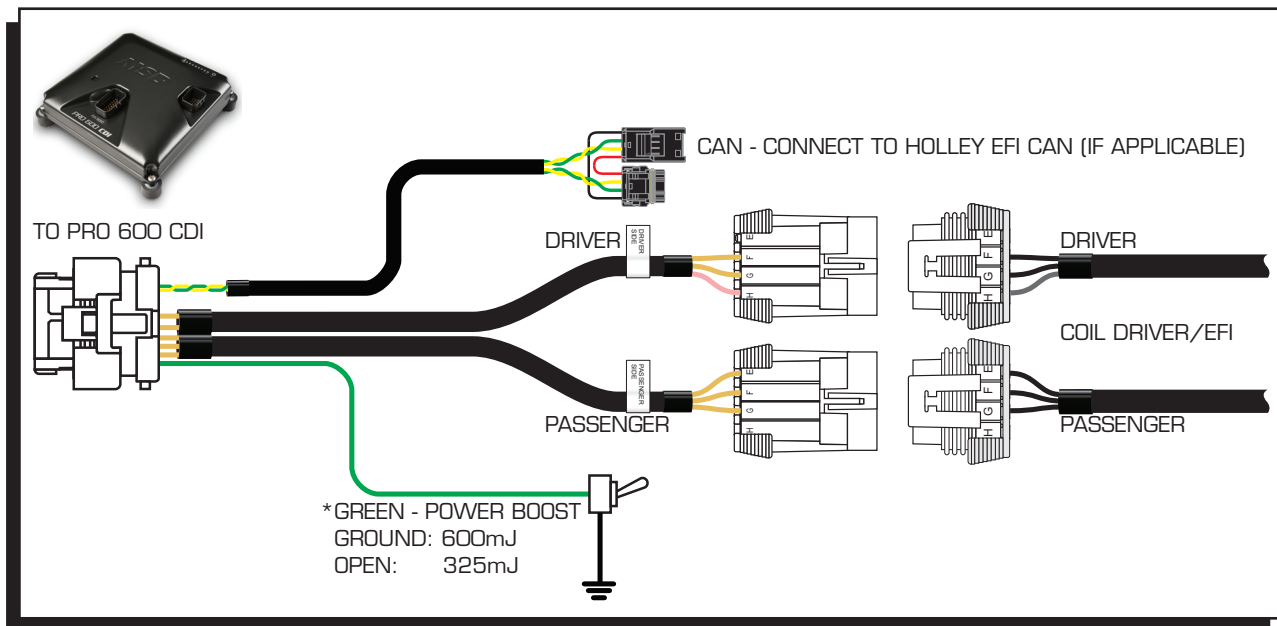
If using the PRO 600 CDI Ignition with the Holley EFI, MSD recommends connecting the CAN connector to the Holley CAN network. This connection provides additional control and diagnostics through the Holley EFI software.

- Connect the 14-pin connector of the EFI Harness to the PRO 600 CDI Ignition.
- Connect the Green wire pin 6 in the 14-pin connector to ground when full power is required. For Holley EFI systems see note.

Note: When using CAN with a Holley EFI, the Holley EFI controls the ignition output power. In this case, the Green wire is not used and should be left unconnected. Please refer to the Holley EFI documentation for additional information and calibration.

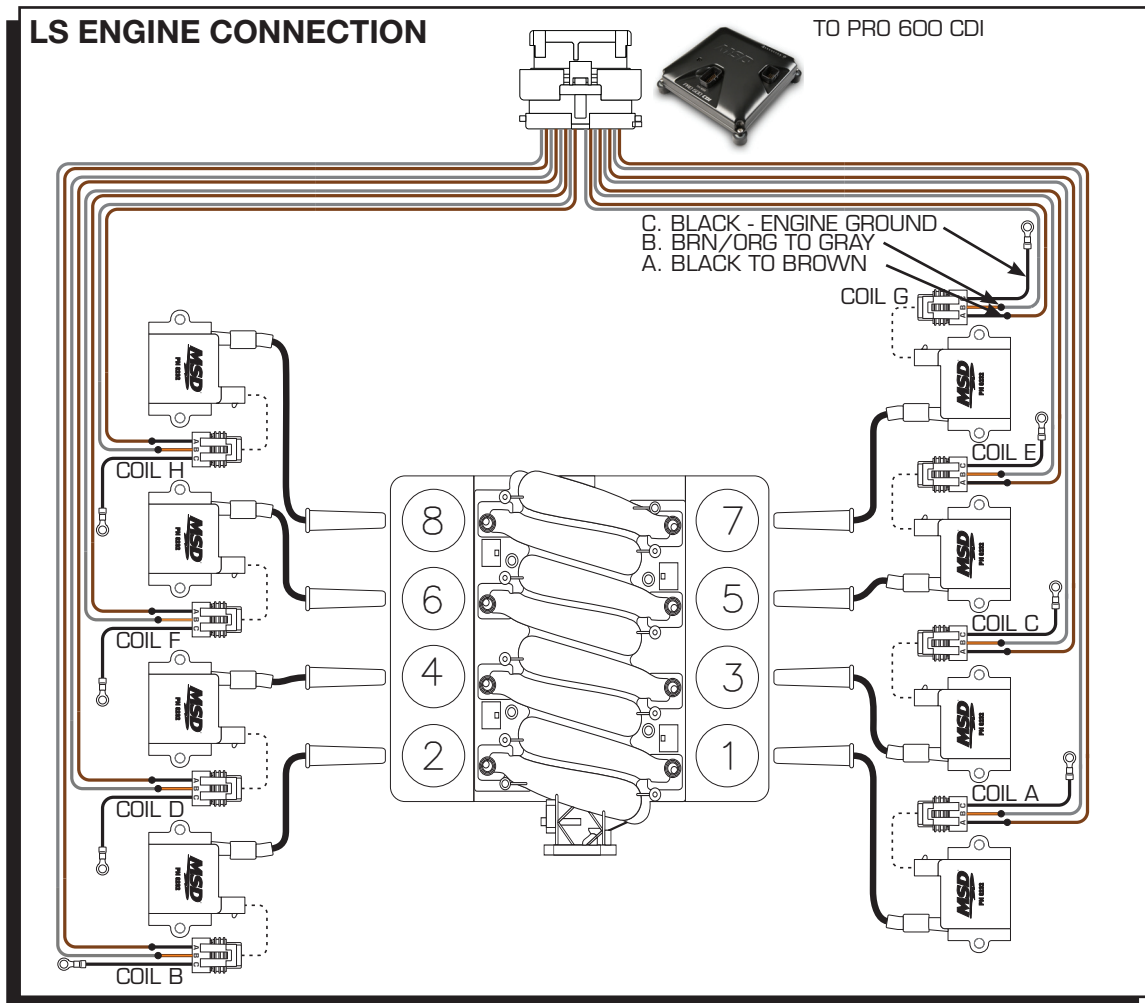

Figure 7. LS Engine Coil Connection

Coil Wires - LS Mode

When using the included LS EFI harness, the inputs are prewired to a coil output from the EFI. The output of cylinder 1 is connected to input A, the output of cylinder 2 is connected to input B and so on until the output of cylinder 8 is connected to input H.

- Connect each of the paired outputs A to H to its corresponding coil 1 thru 8 as in Figure 7.

Output A to Cylinder 1, Output B to Cylinder 2, Output C to Cylinder 3, Output D to Cylinder 4
Output E to Cylinder 5, Output F to Cylinder 6, Output G to Cylinder 7, Output H to Cylinder 8

POWER-GRID CONNECTION

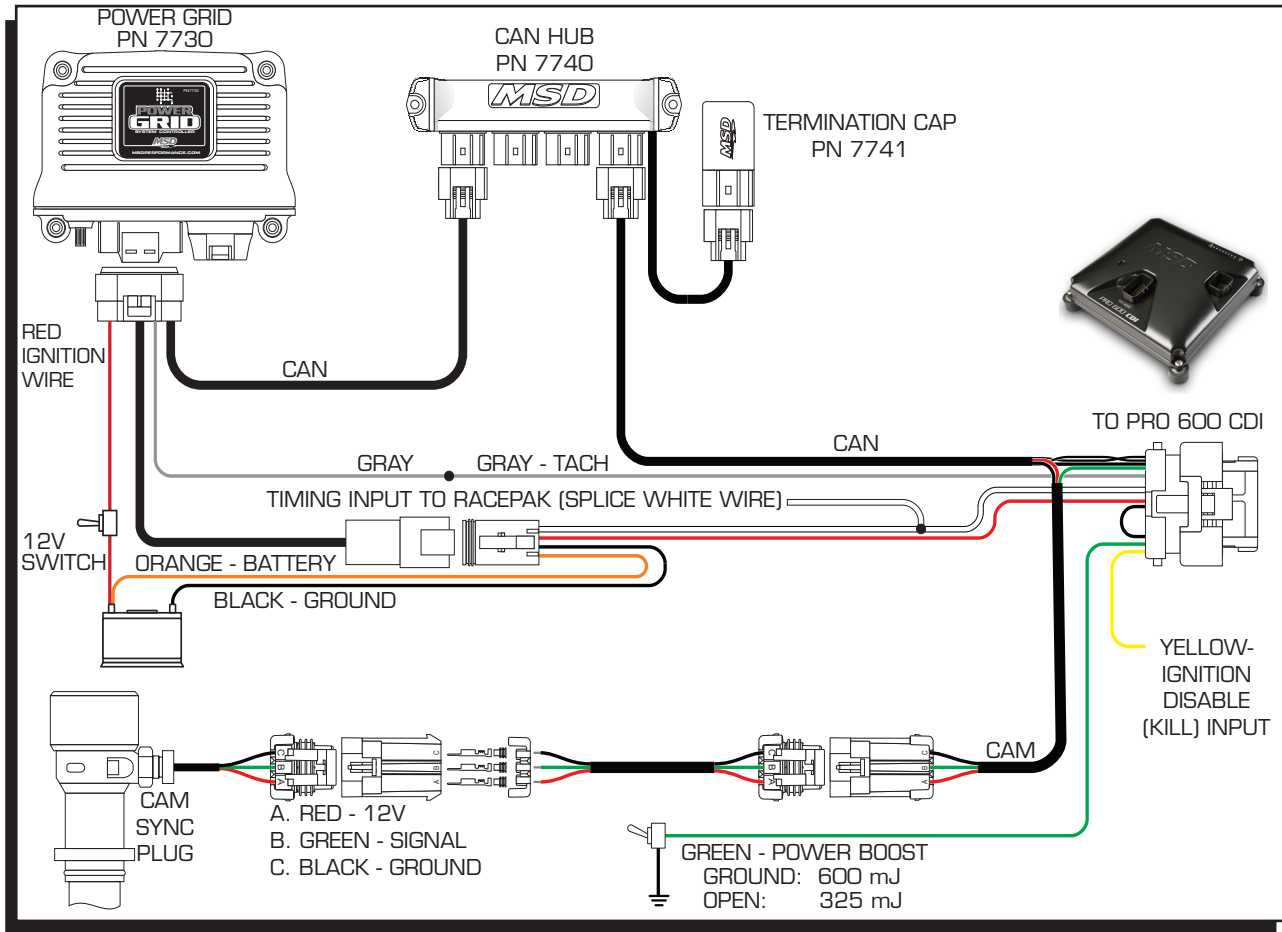

Figure 8. Power Grid Connection

Installation:

- Connect the 4-pin connector to the matching 4-pin connector of the Power-Grid.
- Connect the Orange wire, pin 4, to the Battery positive.
- Connect the Black wire, pin 2, to the Battery Negative.
- Connect the TACH IN, Gray wire, pin 4, in the 14-pin connector to the Gray wire of the MSD PN 7730.
- Connect the Green wire pin 6 in the 14-pin connector to ground when full power is required.

For a timing input signal, splice into the white wire, pin 3 on the 4 pin connector.

Power-Grid Setup

Under *Settings General*:

Set *Ignition Type* to *Network Ignition* and the *Tach Output Sync* to *Crank Input*.

Note: In *Network Ignition* mode the ignition uses the Tach input as part of syncing and the Ignition signal for firing the spark.

Note: Grounding the Yellow wire disables (Kills) the ignition.

POWER-GRID/PROFILER APPLICATION CONNECTION

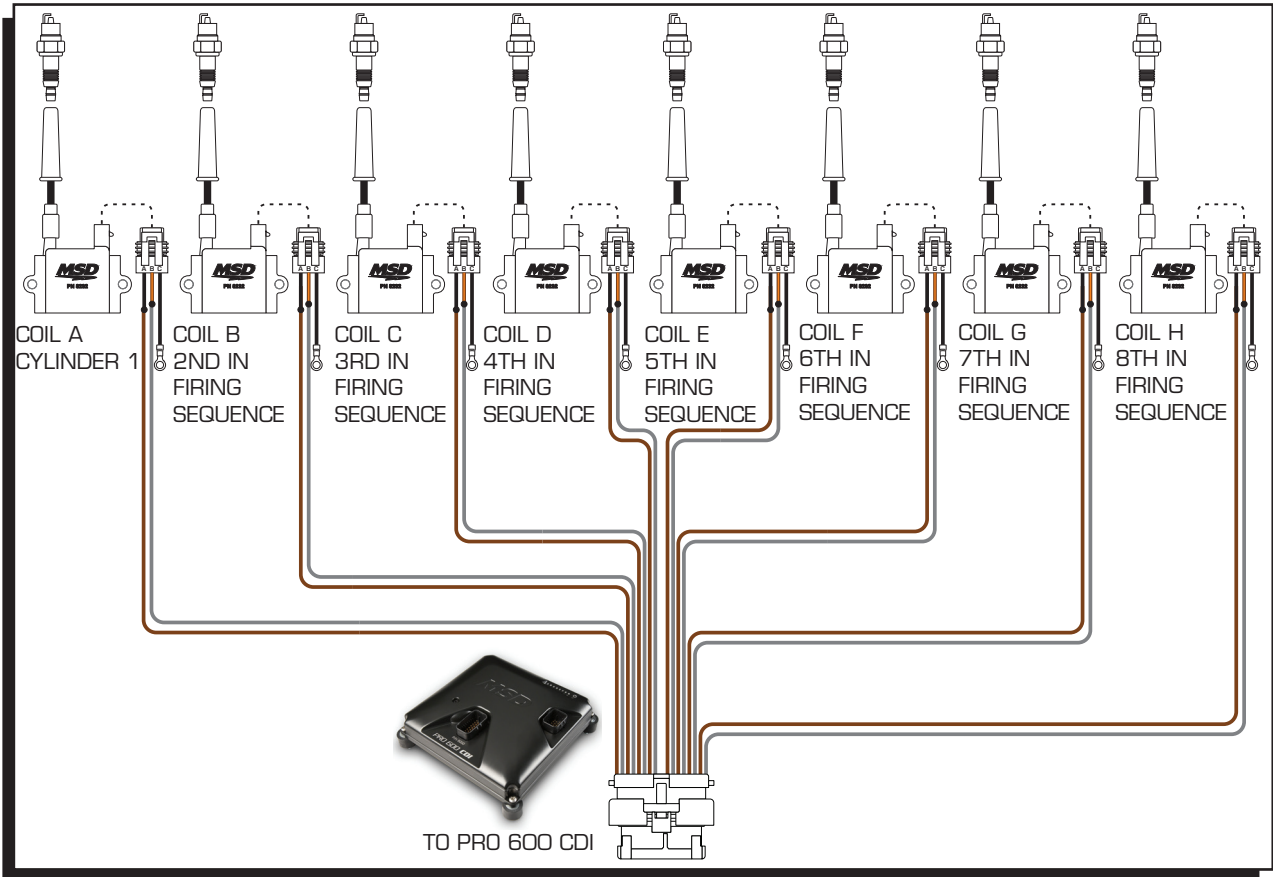

Figure 9. Generic Engine (Non-LS) Coil Connection

POWER-GRID MODE / PROFILER MODE - FIRING ORDER

Write the firing order in Table 2, starting with cylinder 1 below the sequence A thru H to determine the relationship between output wire pairs and coils. Connect each labeled output wire pair to the corresponding coil as determined by the firing order.

Warning: Failure to connect the secondary of the ignition coil to ground and to the spark-plug while operating the ignition may cause an electrical shock or damage to electronic components.

Output Wire Pair	A	B	C	D	E	F	G	H
Firing Order	1	—	—	—	—	—	—	—

Table 2. Firing Order

Theory of Operation

In Power-Grid or Profiler mode, a coil fires on every rising edge of input A on the 14-pin connector. Input A is connected to the ignition output, White wire, in the 4-pin connector to the Power-Grid. The coil outputs are synchronized with the CAM sensor. The CAM sensor signal is connected to Input B. The Tach wire is Input C, and it is connected to the Gray wire. Output A fires first after a CAM signal is goes low. The CAM signal needs to lead the Tach (Crank) signal, Input C, by 5 to 60 degrees to be valid. The sequence is A, B, C, D, E, F, G, H. LEDs E, F, and G on the Pro 600 can be used to adjust the CAM Sync Plug to the optimum location, around 30 degrees before the Tach signal is detected.

MSD VIEW SOFTWARE

The PRO 600 CDI Ignition is designed to operate without the need of software interface. However, the MSD View Power-Grid interface provides the racer with an interface to further control the ignition, perform diagnostics and monitor performance. Download latest software from www.msperformance.com.

Setting:

Trigger Edge

Most Smart Coils such as LS coil require the ignition to trigger on **FALLING EDGE**.

The Power-Grid or the Profiler requires the ignition to trigger on **RISING EDGE**.

In **AUTO** mode the ignition updates to the correct edge automatically.

Rev Limiter

This setting can be set as the maximum rev limiter.

High Power Ignition Energy

The ignition output energy available while the Power Boost wire (Green) is grounded
Default: 600 Millijoules

Range: 350 to 680 Millijoule

Note: Operating the Pro 600 CDI for an extended period of time at a power level higher than 600 millijoule will increase the internal temperature and may cause the over-temperature protection to reduce the power output.

Normal Power Ignition Energy

The ignition output energy active while the Power Boost wire (Green) is NOT grounded.

Default: 325 Millijoule

Range: 250 to 400 Millijoule

Monitor Items:

Engine Speed

The calculated engine speed based on the timing between consecutive inputs.

Target Voltage

The demanded ignition energy determines the target converter voltage on the ignition capacitor.

Converter Voltage

The measured capacitor voltage.

Charge Time

The time required to reach the converter voltage.

Ignition Voltage

The voltage on the ignition wire.

15V Supply

Internal voltage supply for the Power Drivers.

SETTINGS		
Function	Value	Units
Trigger Edge	AUTO	Select
Rev Limiter	15000	RPM
High Power Ignition Energy	600	Millijoule
Normal Power Ignition Energy	405	Millijoule

Figure 10. Settings

Engine Speed	0	RPM
Target Voltage	0	Volts
Converter Voltage	0	Volts
Charge Time	0	uSec
Ignition Voltage	0.00	Volts
15V Supply	0.00	Volts
Cap Osc 1	0	uSec
Open-Load Counter 1	0	
Efficiency 1	0.00	
MAX temperature	0.0	°C
MAX Engine Speed	0	RPM
MAX Power	0	Volts
Time To MAX Temp	0.00	Min
CAM Timing	0.0	°

Figure 11. Power Grid Connection

Cap Osc 1 to Cap Osc 8

The AC spark cycles energy from the ignition capacitor to the ignition coil and back. The Cap Osc is the period of the first ignition oscillation. This oscillation is the effect of the ignition circuit resonance frequency. Each type of ignition coil may have a different frequency. A deviation from the typical period (frequency) can indicate an issue with that channel. For example, a shorted coil causes the period to shorten (higher frequency) while an open load causes the period to increase (lower frequency). A value below 100 μ s or above 200 μ s will trigger a fault in the corresponding coil.

Open-Load Counter 1 to Open-Load Counter 8

The Open-Load Counters are diagnostic indicators that increment each time the ignition detects an Open-Load condition. An Open-Load condition occurs when the secondary voltage is unable to break the gap, and no secondary current occurs. An Open-Load event is determined when the Cap-Osc period is longer than 200 μ s.

Caution: Do not use high inductance coils. They may trigger the Open-Load diagnostic and degrade the ignition's performance.

System Temperature

Two temperature sensors monitor the internal temperature. The system temperature displays the highest value. When the internal temperature exceeds 257° F (125° C), the ignition reduces its output power as a protective measure from permanent damage.

Efficiency 1 to Efficiency 8

The AC spark cycles energy from the ignition capacitor to the ignition coil and back. The efficiency is the ratio between the ignition capacitor energy after the first ignition cycle to initial available energy. Typically, this ratio is around 60%, but it is dependent on the ignition coil used and spark load. A number too low indicates system losses while a number too high indicates insufficient energy transfer to the spark plug. For example, a shorted primary or open load causes the efficiency number to increase. Alternatively, excessive losses in the ignition output circuit may cause the efficiency number to drop. In most cases, the number between all cylinders is similar. Large deviations of efficiency in one or more channels from the others indicates of a potential issue with the coil or the spark plug.

MAX temperature

The maximum internal temperature of the ignition. The value can be cleared using the *Reset Diagnostic* button.

Note: For optimum performance, this value should not exceed 257° F (125° C).

MAX Engine Speed

The maximum measured Engine Speed. The value can be cleared using the *Reset Diagnostic* button.

MAX Power

The maximum ignition output power. The value can be cleared using the *Reset Diagnostic* button.

Time to MAX temp

The time from key ON to the maximum measured temperature. The value can be cleared using the *Reset Diagnostic* button.

CAM Timing

The measured CAM timing relative to the Tach input. Should be set to 30 degrees +/-10 degrees. Adjust the CAM Sync Plug to obtain a value close to 30. The default value when the engine is OFF is 0. LEDs E, F, and G can be used to adjust the CAM Sync Plug. Note: LEDs E, F, and G provide a convenient visual to set the CAM Sync Plug to the correct position. The CAM Sync Plug should be adjusted for only LED F is ON while the engine is running.

DAVIS PROFILER CONNECTION

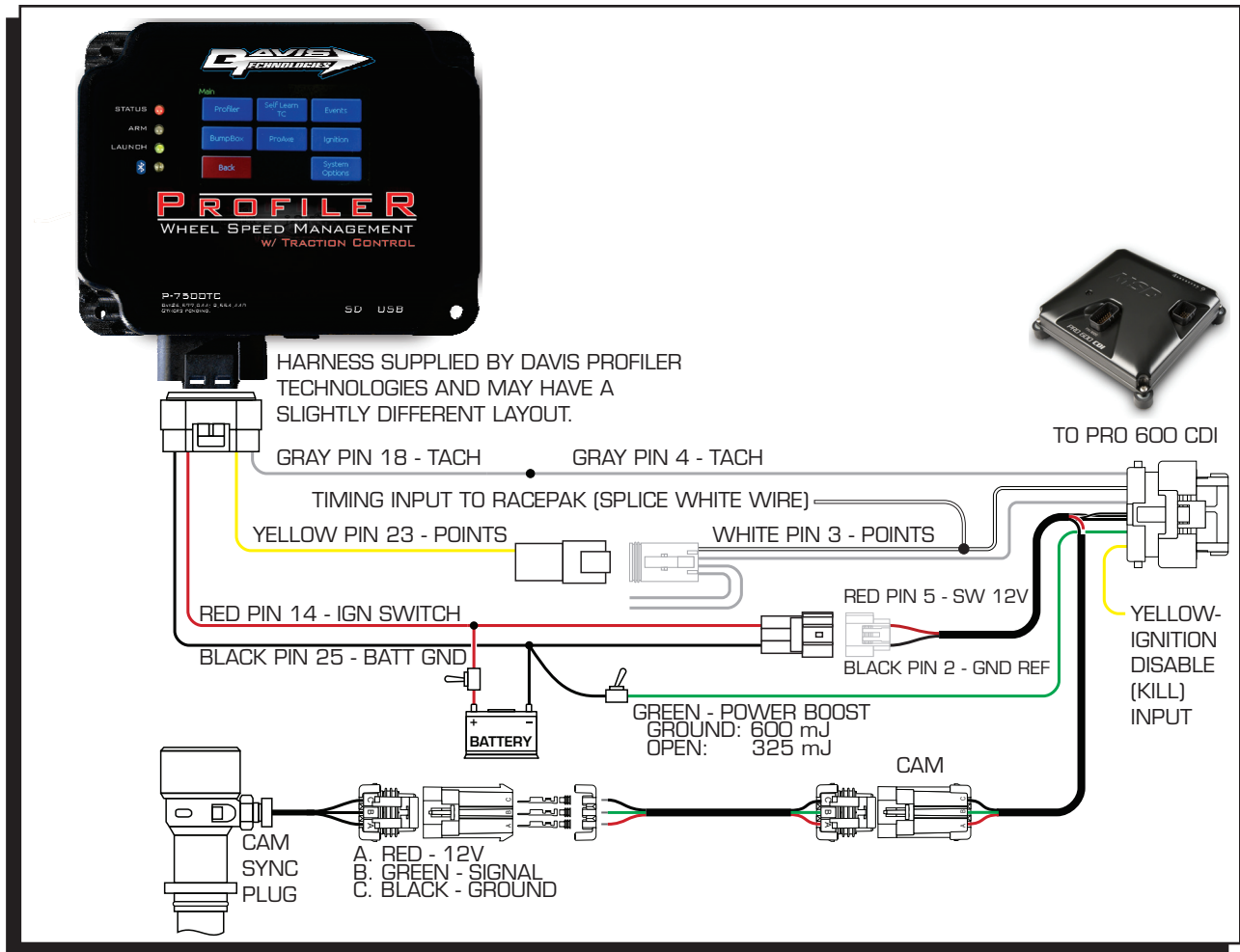

Figure 12. Davis Profiler Connection

INSTALLATION:

Note: Use the special Davis Profiler wiring harness to interface with PRO 600 CDI

- Connect the 4-pin connector from the Davis Profiler, pin 23, to the the 4-pin connector in the PRO 600 CDI.
- Connect the 6-pin connector from the Davis Profiler to the 6-pin MSD connector (Pin 14 and pin 25 in the Profiler Connector).

- Connect the TACH IN, Gray wire, pin 4 in the 14-pin connector to the Gray wire, pin 18 of the Davis Profiler.
- Connect the Green wire pin 6 in the 14-pin connector to ground when full power is required.

For a timing input signal, splice into the white wire, pin 3 on the 4 pin connector.

Davis Profiler Setup:

Under *System Options*, scroll down to *Configure Outputs* then to *LP6* and select *Engine Rpm (Tach)*. **Make sure to save this change.**

In this mode, the ignition uses the Tach input as part of syncing and the Ignition signal for firing the spark.

Note: Grounding the Yellow wire Kills the ignition.

GENERIC EFI COIL CONNECTIONS

In a generic EFI, there is a need to modify the EFI Harness, ASY35455.

- Remove the two 7-pin connectors from the EFI Harness.
- Connect each of the input wires A through H to its corresponding wire in the EFI coil drivers 1 through 8.
- Connect the Ignition wire, Pink, pin 5 in the 14-pin connector to a switched 12 volts source.
- Connect each output pair in the Coil Harness, ASY34536, to its corresponding ignition coil.

Note: Each of the coil wire pairs, A through H, must be attached to the ignition coil connected to the cylinder number that the input with the same marking A through H is connected on the EFI side.

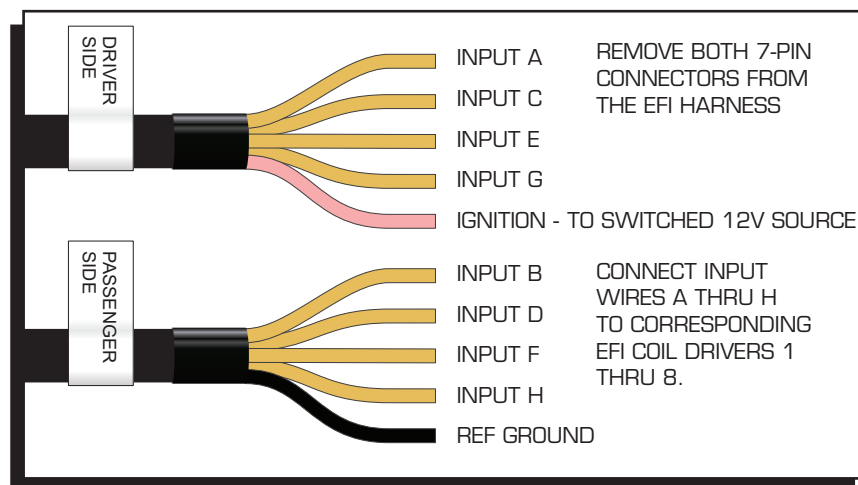

Figure 13. Coil Harness Modifications For a Generic EFI

Pro 600 Monitor and Diagnostic LEDs

Main LED (Power LED) 

Off – no power to the ignition

Green – normal operation Ignition on

Blinking Red – Internal fault.

Orange – Low battery voltage, the battery is less than 6 volts or is in Firmware update mode.



Figure 14. LEDs

EFI Mode

Normal Mode (No-Fault) - Each input, A to H, turns the corresponding LED ON. An unlit LED indicates zero volts at the corresponding input. A lit LED indicates 5 or 12V at the input. When the engine is running the LEDs will blink, but appear faintly ON.

Fault Mode - When a fault is detected in a corresponding output channel the LED will blink twice per second until the fault is corrected. Cycle the ignition switch to reset Fault codes. The Fault blinking LED overrides the Normal function of the LED.

LED Name	EFI Mode		Fault Condition
	ON	OFF	Blinking LED
Main LED	Green - Normal	OFF	N/A
	RED - FAULT		
A	A Input High	A Input Low	A Output FAULT
B	B Input High	B Input Low	B Output FAULT
C	C Input High	C Input Low	C Output FAULT
D	D Input High	D Input Low	D Output FAULT
E	E Input High	E Input Low	E Output FAULT
F	F Input High	F Input Low	F Output FAULT
G	G Input High	G Input Low	G Output FAULT
H	H Input High	H Input Low	H Output FAULT

Table 3. EFI MODE LED STATUS*

***Notes:**

In EFI Mode and Zero RPM, LEDs A to H should be OFF.

The LED blinks as each input turns OFF and ON.

Power Grid/ Davis Profiler Mode

Normal Mode (No-Fault) -

Each of the inputs, A to D, turns the corresponding LED ON. An unlit LED indicates zero volts at the corresponding input. A lit LED indicates voltage at the input or Open wire. When the engine is running the LEDs blink, but may appear faintly ON.

LED A - blinks as the points input toggles.

LED B - blinks as the Cam input toggles.

LED C - blinks as the Tach input toggles.

LED D - ON

Note: Grounding the Ignition Kill wire will toggle the LED off.

LEDs E, F, and G - Provides a convenient way to adjust the Cam Sync plug to the correct position while the engine is running. (The ideal setting is when LED F is ON and LEDs E and G are OFF)

LED H - ON

LED Name	Power Grid Mode		Fault Condition
	ON	OFF	Blinking LED
Main LED	GREEN - NORMAL	OFF	RED - FAULT
A	Points Input High/Open	Points Input Low	A Output FAULT
B	CAM Input High/Open	CAM Input Low	B Output FAULT
C	TACH Input High/Open	TACH Input Low	C Output FAULT
D	IGNITION DISABLE INPUT High/Open	IGNITION DISABLE Low	D Output FAULT
E	See CAM Timing Chart Below		E Output FAULT
F			F Output FAULT
G			G Output FAULT
H	PG/Profiler Mode	N/A	H Output FAULT

Table 4. POWER GRID/DAVIS PROFILER LED STATUS *

Notes:

In Power Grid mode, LEDs A to D indicates the state of the corresponding input. LEDs E, F, and G help in timing adjusting CAM timing.

Fault Modes

When a fault is detected in a corresponding coil output, its LED will blink twice a second (2 hertz) until the fault is corrected. To Reset

active faults cycle the ignition power. If using the Power-Grid, active and history faults can be cleared using the *Reset Diagnostic* button in the MSD View software.

Note: The Fault 2 hertz blink in any of the channels overrides to Normal function of the LED.

Possible faults: Open Coil, Shorted Coil, and Open Load.

Open coil: The primary circuit of the coil is open and there is no energy transfer from the ignition capacitor to the coil.

Shorted Coil: The primary circuit of the coil is shorted and is detected as low inductance.

Open Load: The Secondary circuit of the coil is open and is detected as high inductance.

LED			CAM Timing
E	F	G	
●	○	○	0° - 10°
●	●	○	10° - 20°
○	●	○	20° - 40°
○	●	●	40° - 50°
○	○	●	50° - 90°
○	○	○	No CAM Signal
● LED is ON			
○ LED is OFF			

Table 5. CAM Timing Chart

PRO CDI 600 IGNITION NON-EFI MODE (POWER-GRID/DAVIS PROFILER)

With the Power Grid or the Davis Profiler, a CAM Sync is required to determine the start of the firing sequence of cylinder number 1. The CAM Sync signal initiates the firing sequence to cylinder number 1. For best performance, set the CAM Sync to trigger 30 degrees (+/- 10) before the crank-trigger. To set the CAM Sync, the Crank pickup must be set first.

CAM Sync setup

1. Follow the normal procedure to set the Crank pickup.
2. Verify that the timing mark lines up when cylinder number one is on the compression stroke.
3. Rotate the engine 30 degrees in the **opposite** direction of engine rotation.
4. Insert the CAM Sync into the distributor location and plug the 3-pin connector. (Do not tighten the housing)
5. Turn the Ignition Power ON
6. Rotate the CAM Sync housing (in any direction) until the LED on the sensor turns OFF.
7. Rotate the CAM Sync housing in the **opposite** direction of the distributor rotation until the LED on the sensor just turns ON.
8. Tighten the CAM Sync in place.
9. Start the engine.
10. Verify LED F is on and LEDs E and G are off. (See Table 5)
 IF necessary, loosen and fine tune the CAM Sync housing.
 Make sure housing is secured into place.

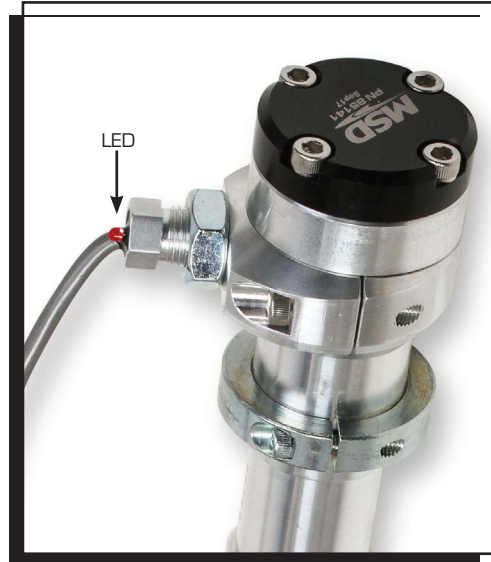
**Figure 16. CAM Sync Distributor LED**

Note: When the CAM Sync is set correctly, while the engine is running, LED F is ON and LEDs E and G are OFF. If necessary, loosen the CAM Sync to fine tune the position of the CAM Sync plug by slowly rotating it clockwise or counterclockwise. When done, retighten the CAM Sync in place.

COIL OUTPUT HARNESS			
23 PIN CONNECTOR			
PIN	COLOR	GAUGE	FUNCTION
1	GRAY	16GA	COIL C
2	BROWN	16GA	COIL
3	BLACK	16GA	PWR GROUND
4	GRAY	16GA	COIL B
5	BROWN	16GA	COIL
6	GRAY	16GA	COIL A
7	BROWN	16GA	COIL
8	GRAY	16GA	COIL D
9	RED	16GA	BATTERY
10	BLACK	16GA	PWR GROUND
11	BLACK	16GA	PWR GROUND
12	-	-	-
13	BROWN	16GA	COIL
14	BROWN	16GA	COIL
15	GRAY	16GA	COIL H
16	RED	16GA	BATTERY
17	RED	16GA	BATTERY
18	GRAY	16GA	COIL G
19	BROWN	16GA	COIL
20	GRAY	16GA	COIL E
21	BROWN	16GA	COIL
22	GRAY	16GA	COIL F
23	BROWN	16GA	COIL

EFI / LS INPUT ADAPTER			
14 PIN CONNECTOR			
PIN	COLOR	GAUGE	FUNCTION
1	BEIGE	20GA	INPUT A
2	BEIGE	20GA	INPUT B
3	BEIGE	20GA	INPUT C
4	BEIGE	20GA	INPUT D
5	PINK	20GA	IGNITION
6	GREEN	20GA	POWER BOOST
7	-	-	-
8	YELLOW	20GA	CAN HI
9	GREEN	20GA	CAN LO
10	BEIGE	20GA	REF GROUND
11	BEIGE	20GA	INPUT E
12	BEIGE	20GA	INPUT F
13	BEIGE	20GA	INPUT G
14	BEIGE	20GA	INPUT H

CAN MALE CONNECTOR (4-PIN)			
PIN	COLOR	GAUGE	FUNCTION
1	RED	20GA	SW POWER
2	YELLOW	20GA	CAN HI
3	GREEN	20GA	CAN LO
4	BLACK	20GA	GROUND

CAN FEMALE CONNECTOR (4-PIN)			
PIN	COLOR	GAUGE	FUNCTION
1	RED	20GA	SW POWER
2	YELLOW	20GA	CAN HI
3	GREEN	20GA	CAN LO
4	BLACK	20GA	GROUND

DRIVERS SIDE CONNECTOR (7-PIN)			
PIN	COLOR	GAUGE	FUNCTION
A	-	-	-
B	BEIGE	20GA	INPUT G
C	BEIGE	20GA	INPUT E
D	-	-	-
E	-	-	-
F	BEIGE	20GA	INPUT C
G	BEIGE	20GA	INPUT A
H	PINK	20GA	IGNITION

PASSENGER SIDE CONNECTOR (7-PIN)			
PIN	COLOR	GAUGE	FUNCTION
A	-	-	-
B	BEIGE	20GA	INPUT B
C	BEIGE	20GA	INPUT D
D	-	-	-
E	BEIGE	20GA	EFI REF GND
F	BEIGE	20GA	INPUT F
G	BEIGE	20GA	INPUT H
H	-	-	-

LOOSE WIRES			
PIN	COLOR	GAUGE	FUNCTION
-	GREEN	20GA	POWER BOOST

POWER GRID ADAPTER			
14 PIN CONNECTOR			
PIN	COLOR	GAUGE	FUNCTION
1	WHITE	20GA	POINTS
2	GREEN	20GA	CAM
3	GRAY	20GA	TACH IN
4	YELLOW	20GA	IGN DISABLE
5	RED	20GA	IGNITION
6	GREEN	20GA	POWER BOOST
7	BLACK	20GA	POWER GRID JUMPER
8	GRN/YEL	20GA	CAN HI
9	BLACK	20GA	CAN LO
10	BLACK	20GA	REF GROUND
11		-	
12		-	
13		-	
14	BLACK	-	POWER GRID JUMPER

LOOSE WIRES			
PIN	COLOR	GAUGE	FUNCTION
-	GRAY	20GA	TACH IN
-	YELLOW	20GA	IGN DISABLE
-	GREEN	20GA	POWER BOOST

CAN CONNECTOR (6-PIN)			
PIN	COLOR	GAUGE	FUNCTION
1	BLACK	20GA	CAN LO
2	BLACK	20GA	REF GROUND
3	-	-	-
4	GRN/YEL	20GA	CAN HI
5	RED	20GA	12V
6	-	-	-

CAM CONNECTOR (3-PIN)			
PIN	COLOR	GAUGE	FUNCTION
A	RED	20GA	12V
B	GREEN	20GA	CAM
C	BLACK	20GA	GROUND

POINTS/POWER CONNECTOR (4-PIN)			
PIN	COLOR	GAUGE	FUNCTION
1	RED	20GA	IGNITION
2	BLACK	20GA	GROUND
3	WHITE	20GA	POINTS
4	ORANGE	20GA	BATTERY

Service

In case of malfunction, this MSD component will be repaired free of charge according to the terms of the warranty. When returning MSD components for warranty service, **Proof of Purchase** must be supplied for verification. After the warranty period has expired, repair service is based on a minimum and maximum fee.

All returns must have a Return Material Authorization (RMA) number issued to them before being returned. To obtain an RMA number please contact MSD Customer Service at 1 (888) 258-3835 or visit our website at www.msdpowerperformance.com/rma to automatically obtain a number and shipping information.

When returning the unit for repair, leave all wires at the length in which you have them installed. Be sure to include a detailed account of any problems experienced, and what components and accessories are installed on the vehicle. The repaired unit will be returned as soon as possible using Ground shipping methods (ground shipping is covered by warranty). For more information, call MSD at (915) 855-7123. MSD technicians are available from 7:00 a.m. to 5:00 p.m. Monday - Friday (mountain time).

Limited Warranty

MSD warrants this product to be free from defects in material and workmanship under its intended normal use*, when properly installed and purchased from an authorized MSD dealer, for a period of one year from the date of the original purchase. This warranty is void for any products purchased through auction websites. If found to be defective as mentioned above, it will be repaired or replaced at the option of MSD. Any item that is covered under this warranty will be returned free of charge using Ground shipping methods.

This shall constitute the sole remedy of the purchaser and the sole liability of MSD. To the extent permitted by law, the foregoing is exclusive and in lieu of all other warranties or representation whether expressed or implied, including any implied warranty of merchantability or fitness. In no event shall MSD or its suppliers be liable for special or consequential damages.

*Intended normal use means that this item is being used as was originally intended and for the original application as sold by MSD. Any modifications to this item or if it is used on an application other than what MSD markets the product, the warranty will be void. It is the sole responsibility of the customer to determine that this item will work for the application they are intending. MSD will accept no liability for custom applications.