



Holley Accessory Drive Kit

P/Ns: 20-290, 20-290BK, 20-291, 20-291BK, 20-292, 20-292BK, 20-293, & 20-293BK

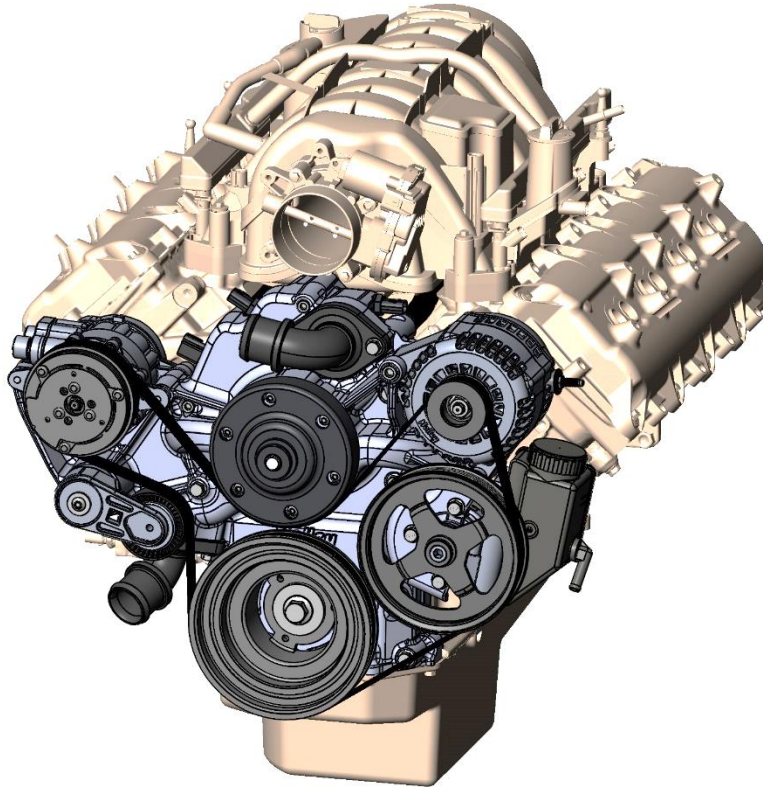
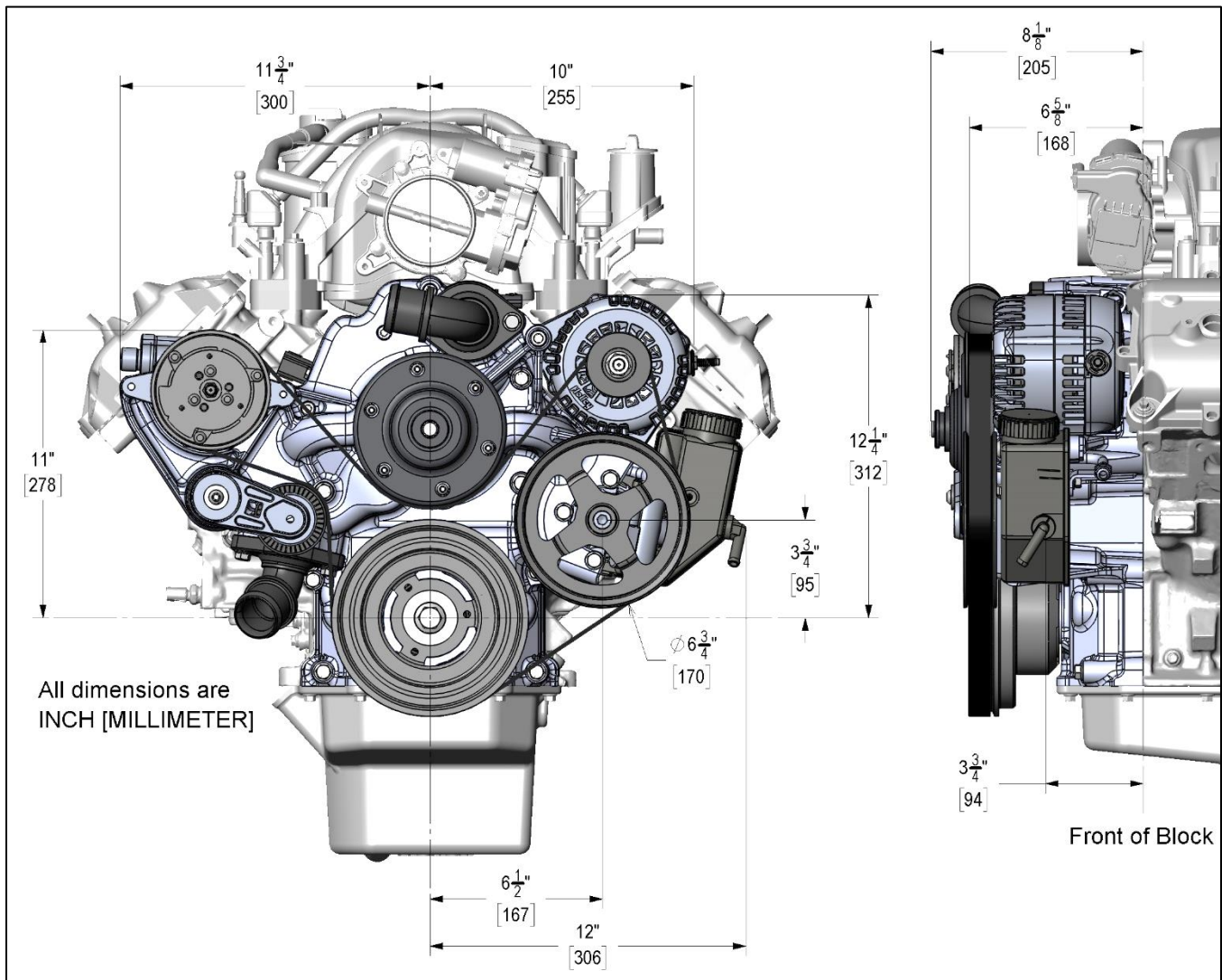

Table of Contents

Dimensions:	2
Introduction:	2
Application Notes:	2
Parts List:	4
Timing Cover Installation:.....	6
Water Pump Installation:	12
Alternator Installation:	13
P/S Pump/Reservoir Installation:	14
Water Inlet/Outlet Installation:	15
A/C Compressor Installation:	17
Belt Tensioner Installation:.....	18
Belt Installation:.....	19
Accessory and Tensioner Covers:	19

Dimensions:



Introduction:

Holley's Mid-Mount complete accessory system has all accessories pulled in tighter than other accessory drives. Among the many swap friendly features is the "bracket-less" assembly that mounts all accessories to the timing cover directly.

IMPORTANT NOTE IF PAINTING COMPONENTS: The alternator and A/C compressor ground through the timing cover. If painting or coating the cover, the mating surfaces must all be bare metal allowing a ground path from the accessories' mounting feet to the engine block and ultimately the negative terminal on the battery.

NOTE: Engines with a front mounted EGR valve may have interference to the accessory drive. In these cases, the EGR valve will need to be relocated.

Application Notes:

The Gen 3 Hemi is available in Non-VVT (2002-2008) and VVT (2009-Present) versions. The Mid-Mount Accessory Kits have been created in versions compatible with either engine design.

The timing cover can be identified by markings where the cam sensor is to be installed (shown below). Confirm that the cover included in kit matches your application.

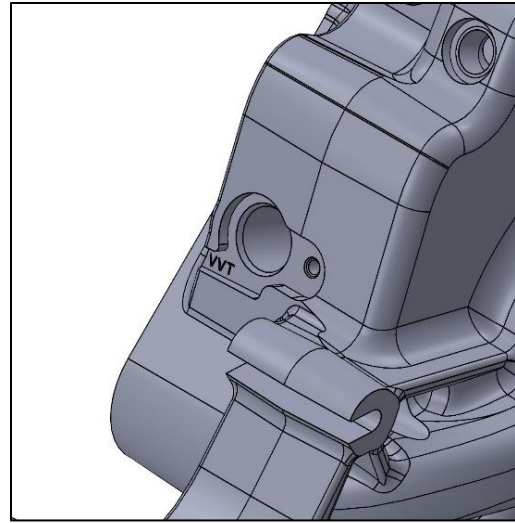
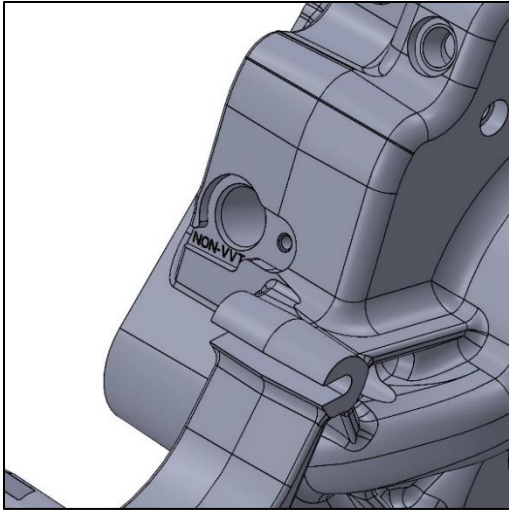

The damper pulley can be identified by measuring overall depth, and come in OE style and ATI versions depending on the kit. Confirm that the parts included match the dimensions below for your application.

Non-VVT OE Damper

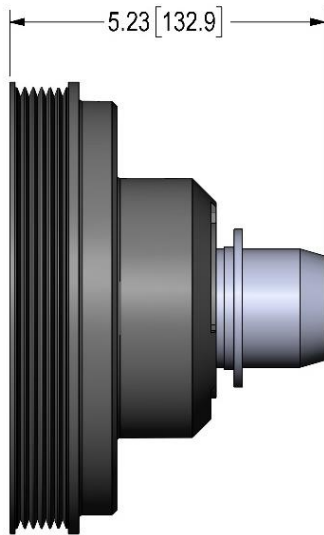

VVT OE Damper

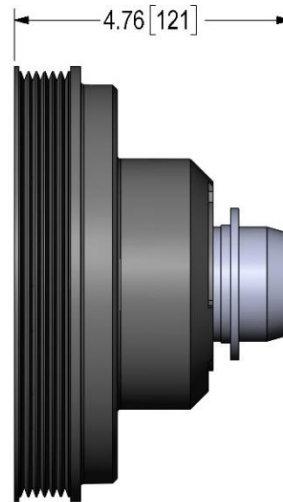

Non-VVT ATI Damper Hub (P/N: 652)

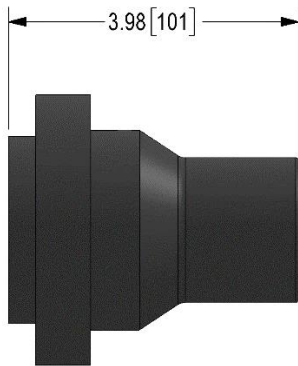



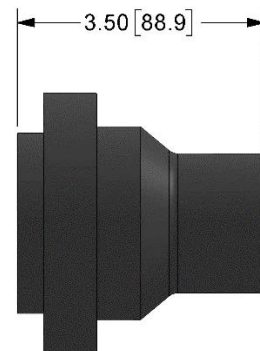





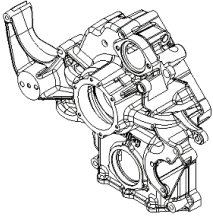

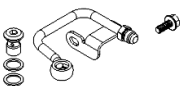

VVT ATI Damper Hub (P/N: 916246)

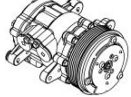

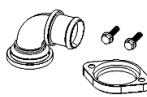
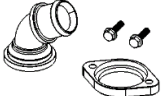

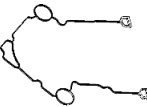

NOTE: Identification numbers for the ATI hubs can be found on the back of the flange.

Parts List:

PICTURE	QTY	DESCRIPTION	REPLACEMENT MANUFACTURER & P/N
	1	Timing Cover	Holley 97-372 (Non-VVT Natural) / 97-373 (Non-VVT Black) 97-374 (VVT Natural) / 97-375 (VVT Black)
	1	Water Pump Drive Assembly / Gasket	Holley 97-200 / GM 12619770
	1	Alternator	Holley 197-302 (Natural) / 197-303 (Black)
	1	Alternator Pigtail	Holley 197-400
	1	P/S Pump	Holley 198-101
	1	P/S Pump Hardline	Holley 198-203
	1	P/S Pulley	Holley 97-152
	1	SD7 A/C Compressor	Holley 199-102 (Natural) / 199-104 (Black)
	1	Adapter Manifold for A/C Compressor	Holley 199-202
	1	Tensioner Assembly with Smooth Pulley	Holley 97-179 / Gates 38163
	1	Water Neck 90 Deg.	Holley 97-341
	1	Water Neck 45 Deg.	Holley 97-343
	1	Thermostat	Gates 34053
	1	Gasket, Cover to Block	Mopar 53021521AD
	1	Plug and Adapter Kit	Holley 97-365

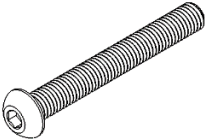
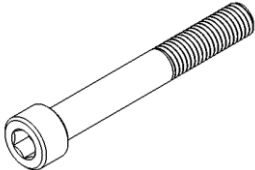
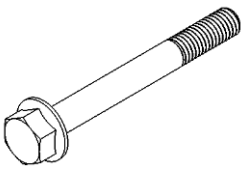
	1	Seal Installation Tool	Holley 97-367
	1	Seal, Cover to Damper	Mopar 53021585AD
	1	Damper Bolt	Mopar 6510763AA
	1	Accessory Belt	Bando 6PK1635

HARDWARE		Replacement Kit 97-366	Hardware Application
	1	Spacer	For A/C Inside Bolt
	1	M8 Washer Oversized	Under Tensioner Bolt
	6	Button Head Bolt M6 X 1.0 X 20	Water Pump to Timing Cover
	1	Button Head Bolt M8 X 1.25 X 70	Tensioner Bolt
	1	Button Head Bolt M10 X 1.5 X 75	Alternator Bolt - Outside
	3	Socket Head Bolt M8 X 1.25 X 100	Cover to Block Top 3 Bolts Passenger's Side
	1	Socket Head Bolt M10 X 1.5 X 75	Alternator Bolt - Inside
	1	Flange Head Bolt M6 X 1.0 X 12	Cam Sensor Bolt
	2	Flange Head Bolt M8 X 1.25 X 16	OE Water Neck to Timing Cover (Optional)
	4	Flange Head Bolt M8 X 1.25 X 30	(3) P/S Pump / (1) Cover Below Water Inlet
	4	Flange Head Bolt M8 X 1.25 X 70	Cover to Block (2) Bottom Bolts / (2) Near P/S Pump
	2	Flange Head Bolt M8 X 1.25 X 95	(1) Cover to Block / (1) A/C Mounting Bolt
	1	Flange Head Bolt M8 X 1.25 X 110	A/C Mounting Bolt - Inside
	1	Flange Head Bolt M8 X 1.25 X 125	Cover to Block Cast Boss Above Inlet

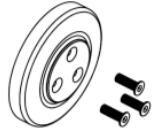
Included Only With: 20-292, 20-292BK, 20-293, & 20-293BK			
	1	Alternator Pulley Cover & O-ring (Black)	Holley 97-187
	1	A/C Compressor Pulley Cover & Hardware (Black)	Holley 97-185

Included Only With: 20-290BK, 20-291BK, 20-292, 20-292BK, 20-293, & 20-293BK			
	1	Tensioner Cover & Hardware (Black)	Holley 97-158

Included Only With: 20-290, 20-290BK, 20-291, & 20-291BK			
	1	Damper, Non-VVT, OE Style	Holley 97-362 (20-290, 20-290BK Only)
	1	Damper, VVT, OE Style	Holley 97-363 (20-291, 20-291BK Only)

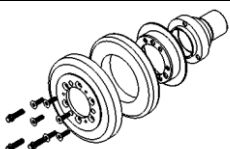
Included Only With: 20-292, 20-292BK, 20-293, & 20-293BK			
	1	Crank Pulley, Billet	Holley 97-359
	1	Hub, Inner Shell, Damper, Outer Shell, & Hardware (crank pulley bolts included with this hardware).	Holley 97-360 (Non-VVT) / 97-361 (VVT)

Assembly Instructions

HELPFUL HINT: The below assembly order is optimized for explanation and the average application. It may be easier to preassemble some components to the timing cover before mounting to the engine. Torquing of the components may however be easier after mounting. Keep in mind adding components increases overall size and weight and may require an additional person when mounting.

Timing Cover Installation:

The first step in installing the cover is to determine how you want to route the heater hoses. The manifold offers the option to run the heater hoses either underneath the intake manifold or to the passenger's side.

NOTE: The fittings must be installed prior to the mating of the timing cover to the block due to interference between the heater hose 90° fitting and the block when threading it into the timing cover.

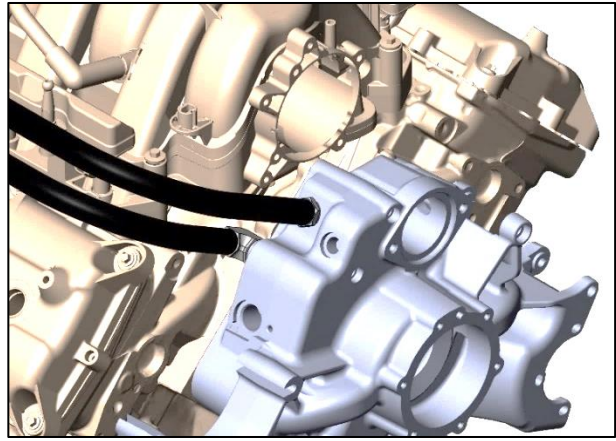
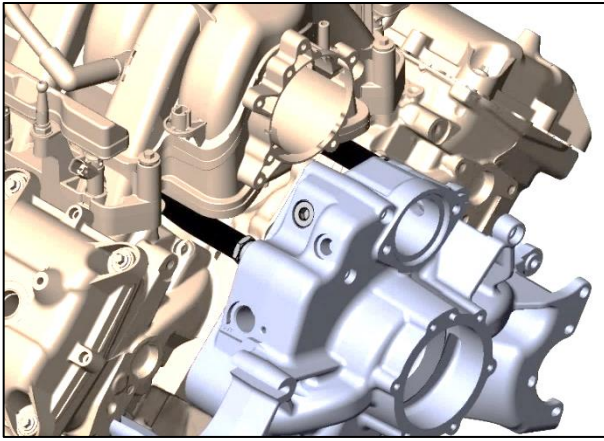

HELPFUL HINT: It may be required to remove the intake manifold to take off the OE heater lines. See your vehicle's service manual for removal and reinstallation details.

NOTE: On all NPT adapters, use thread sealant (Loctite® brand 567 pipe thread sealant or equivalent). Install to finger tight, and then tighten 2 to 3 rounds.

WARNING: Loosening NPT fittings after installation can cause leaks. Do not rotate past final orientation.

Option A: Heater Hose Exit – Rear

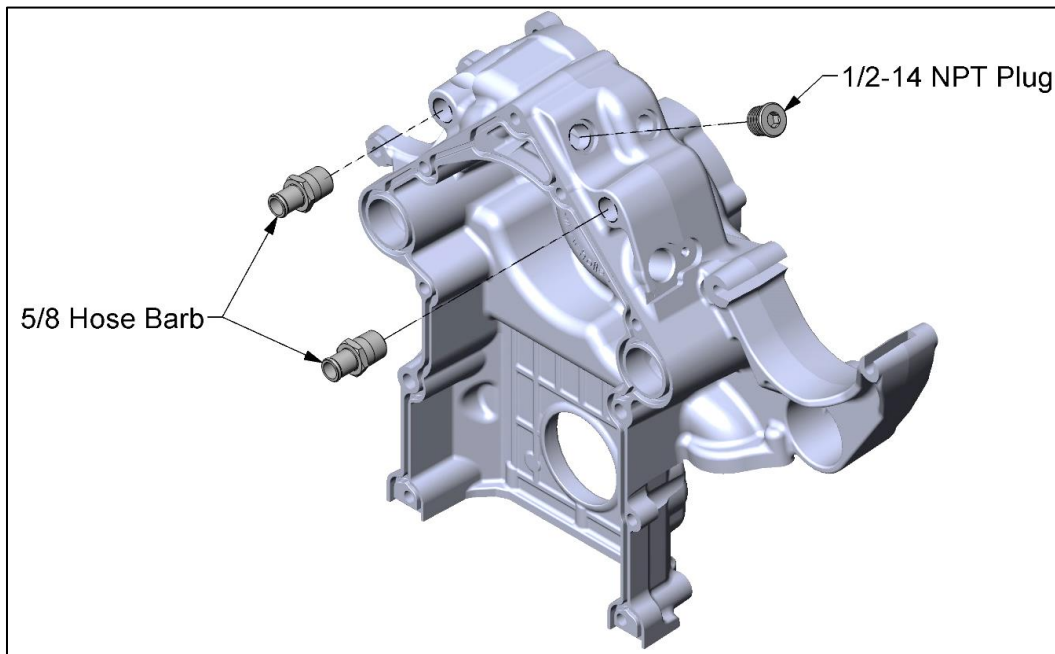

Option B: Heater Hose Exit – Top

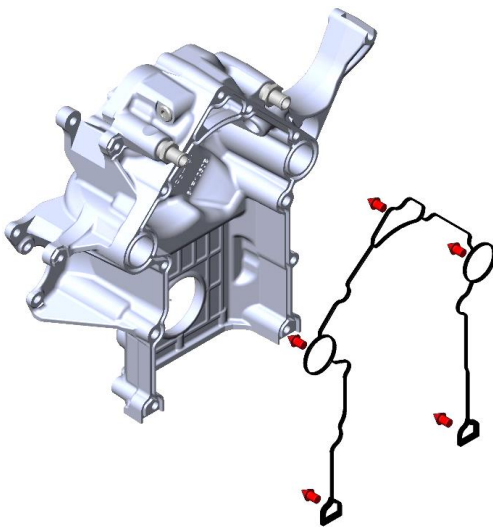
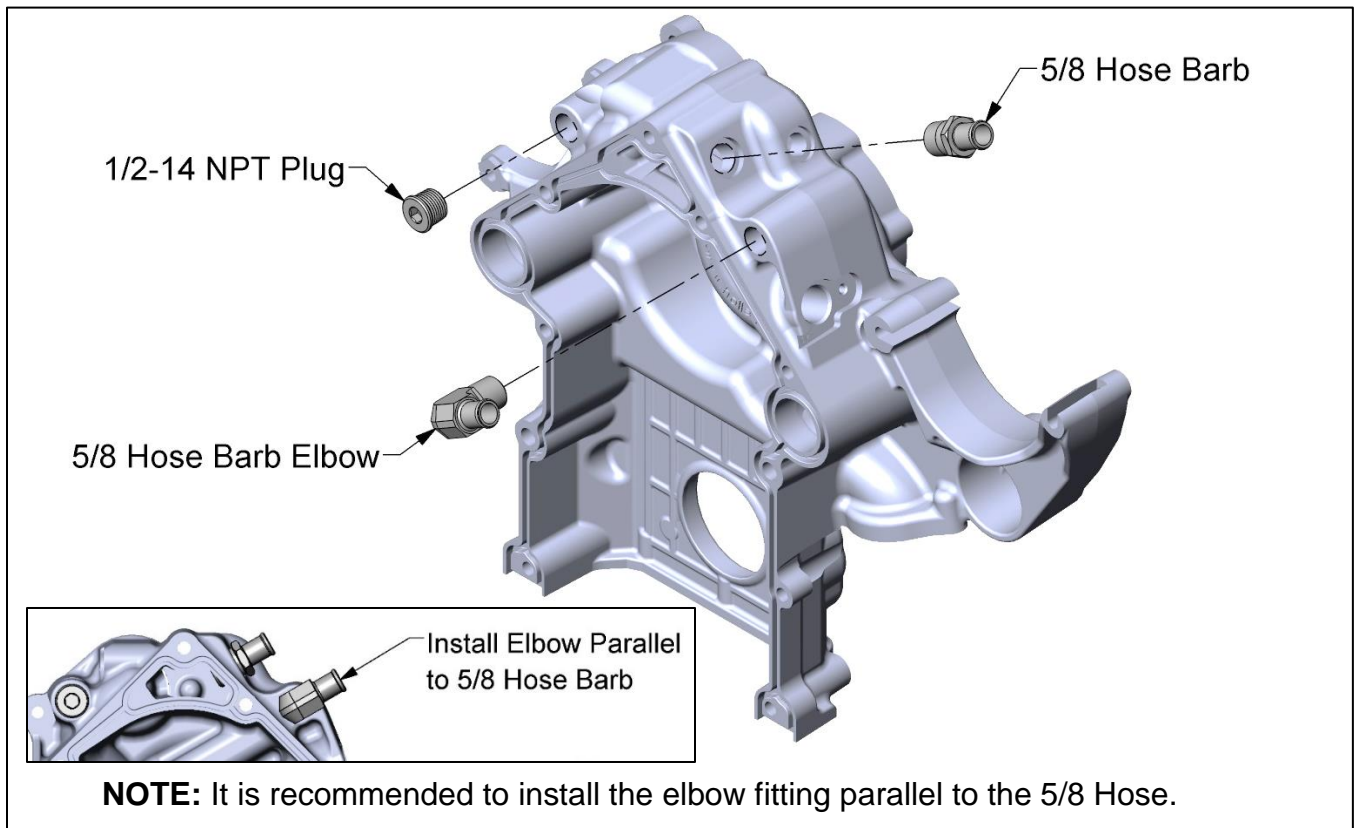

Before installing the timing cover onto the block, install the cover gasket. Install the gasket with the ribbed edge facing the timing cover. Starting at the bottom of the cover and slowly working each side towards the top trying not to stretch the gaskets as it's pushed into the groove. Make sure the gasket is fully seated and push the flats on the bottom upward into the groove.

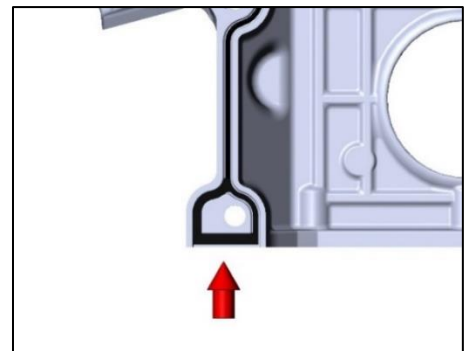

NOTE: Lubricate and install the large green O-ring into the dovetail groove around the water inlet.

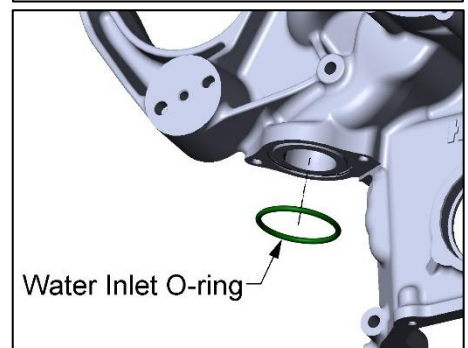

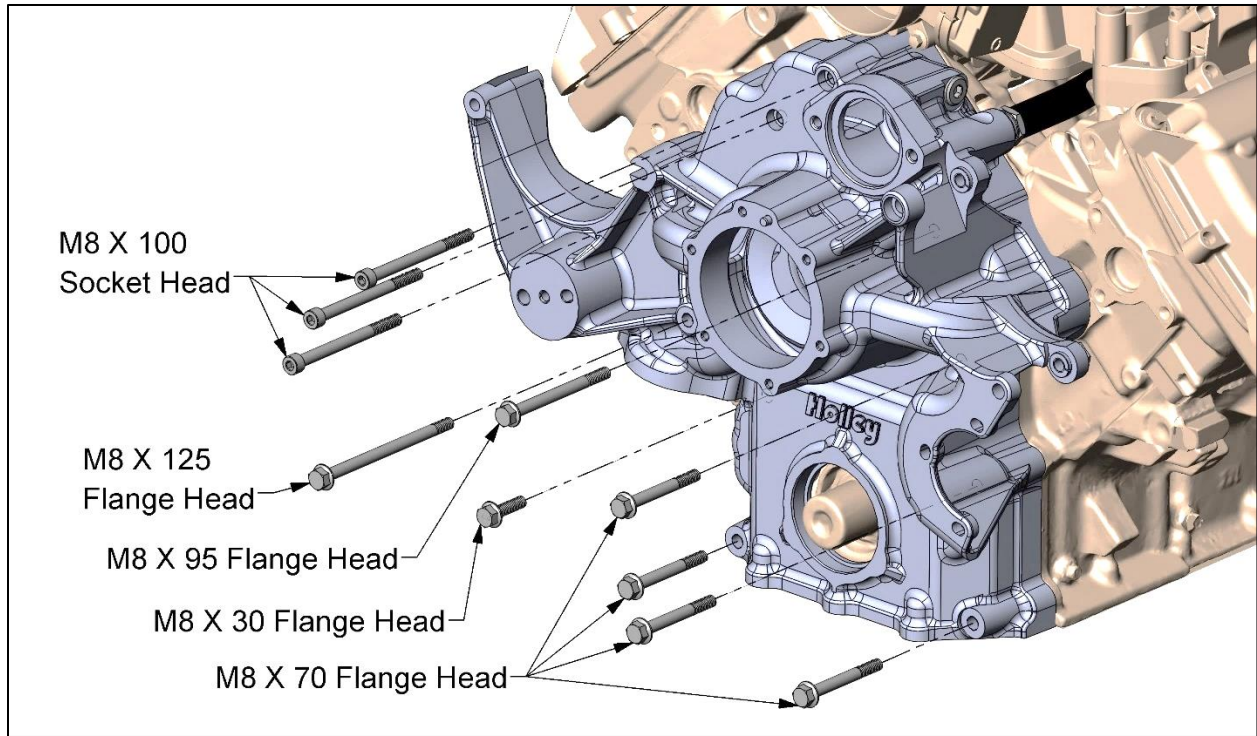

NOTE: Torque M8 bolts to 18 ft./lbs.

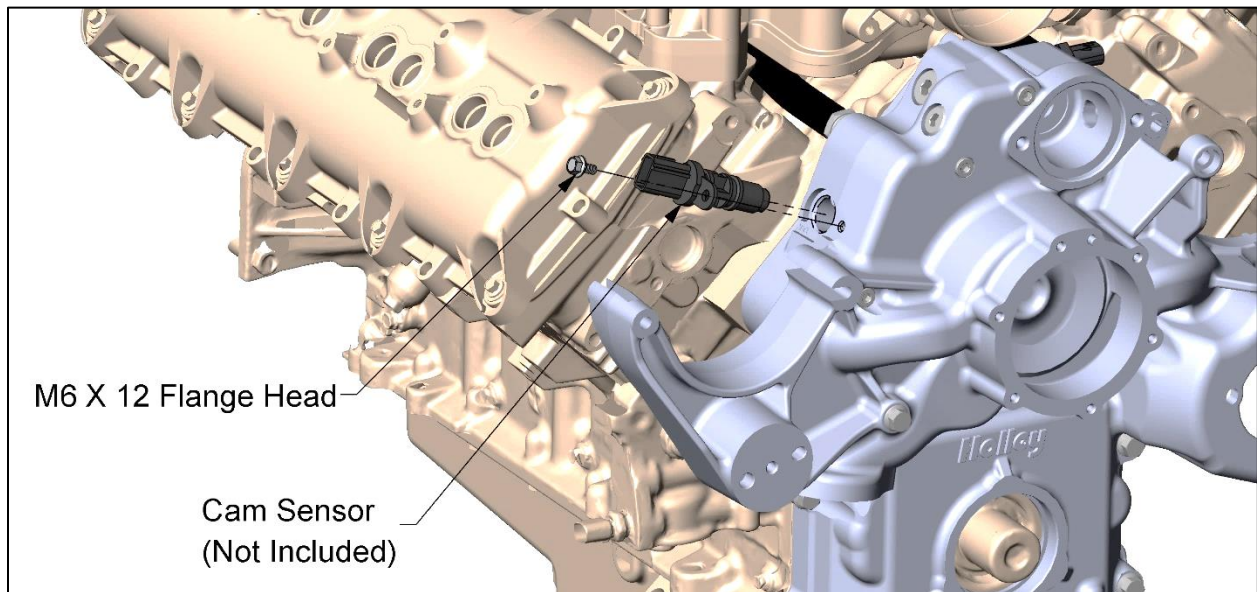

NOTE: Torque M6 bolts to 85 in./lbs.

NOTE: The oil pan can now be installed. Refer to the installation instructions for your application.

There are three installation options for the coolant temperature sensor, to allow for varying harness lengths.

Option 1: If you have an early non-VVT engine, there is an OEM location at the top of the block, behind the thermostat. This requires using Option B for the heater hose routing (pg. 8) due to interference. Use the supplied plugs for timing cover coolant temperature sensor locations.

Option 2: Driver's Side on timing cover – Option A or B can be used for heater hose routing. Use plugs to cap any optional coolant temperature sensor locations.

Option 3: Passenger's Side of timing cover – Option A or B can be used for heater hose routing. Use plugs to cap any optional coolant temperature sensor locations.

WARNING: Coolant Temp sensor must be oriented with connector lock tab in the 12 o'clock position. Sensor must be installed using either a 19MM or 3/4" 6-point deep well socket.

Option 2:

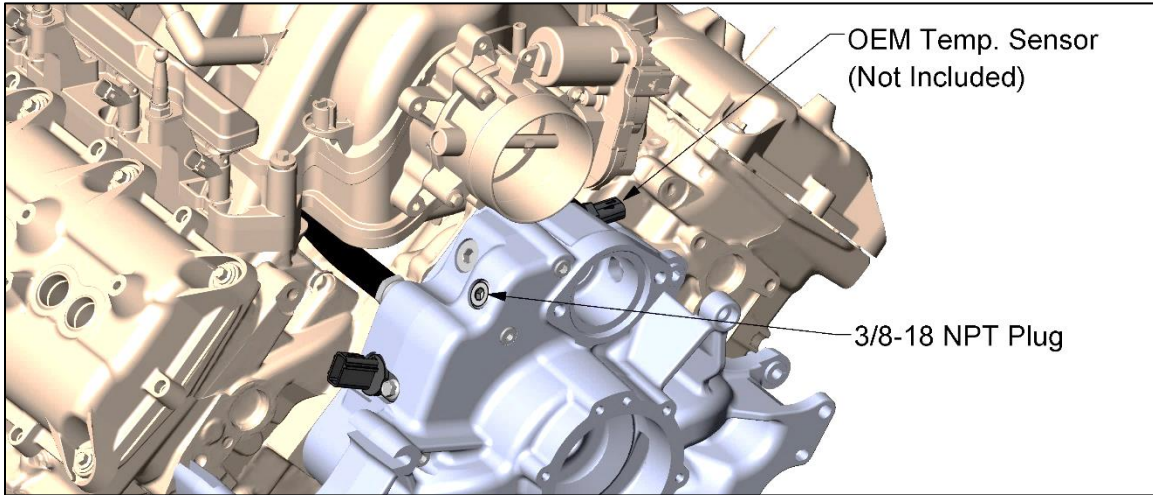

Option 3:

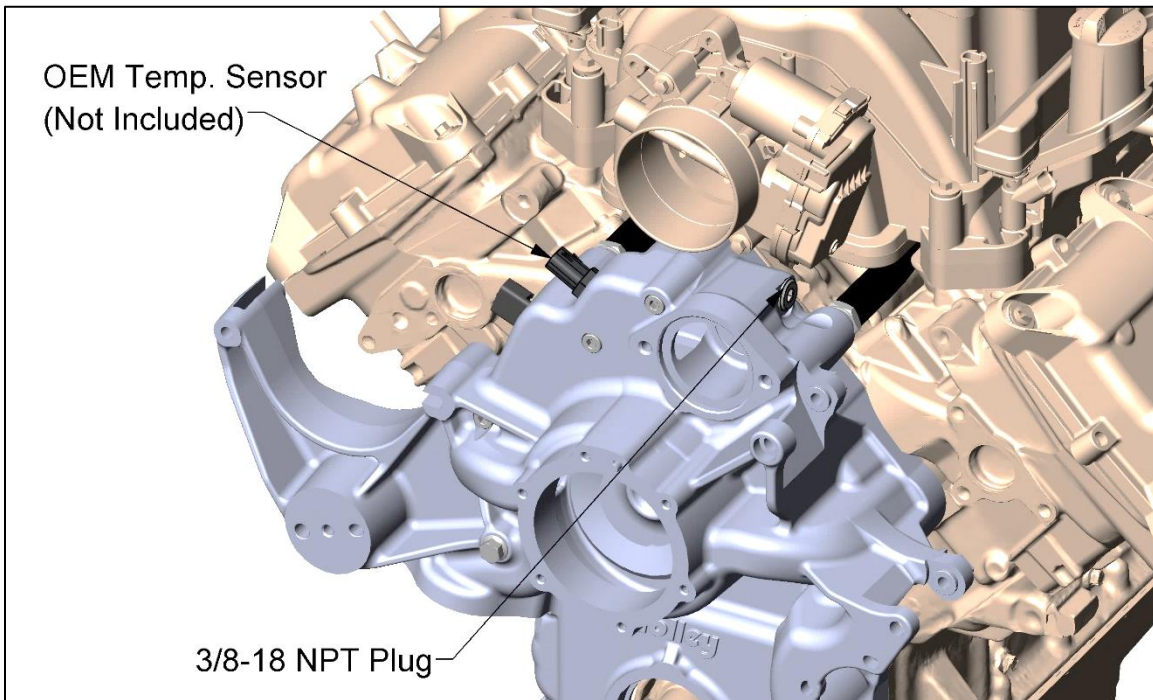

Crank Pulley Installation:

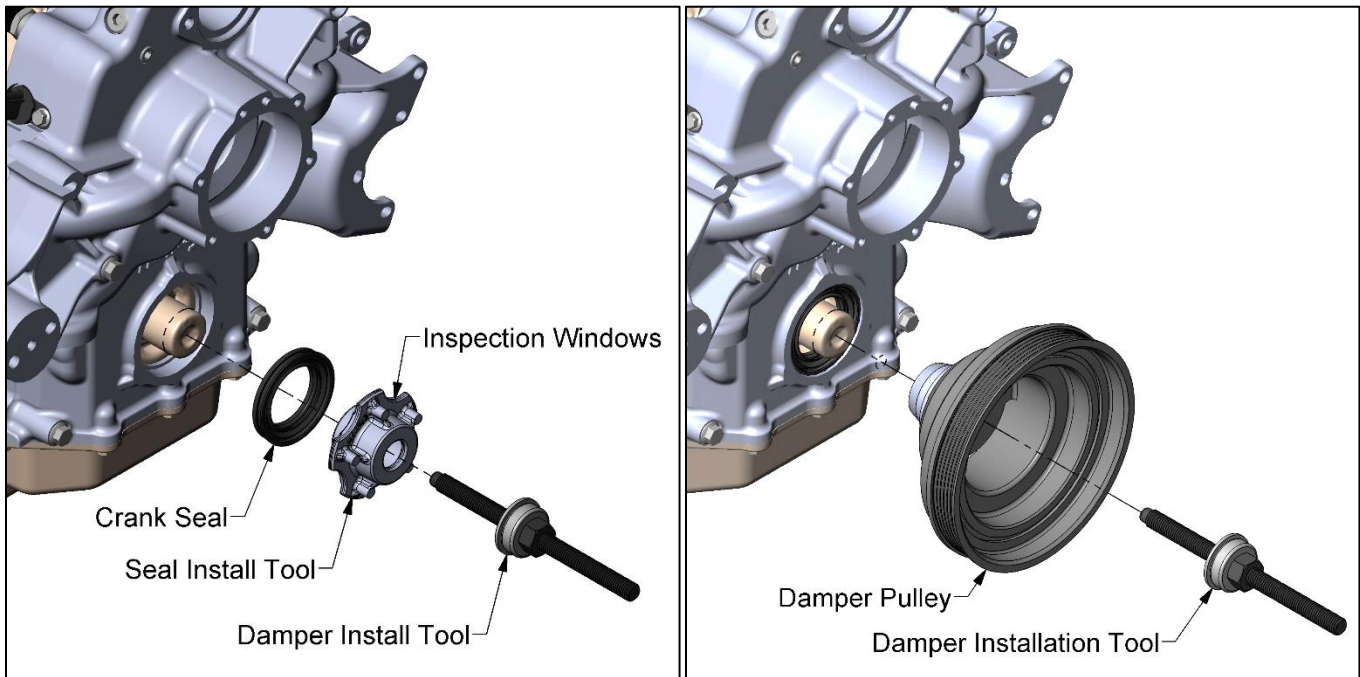

1. The crankshaft seal is to be installed with the rubber side facing out towards the install tool. After lubricating the seal, place it on the tool. Place the seal and tool at the front of the timing cover.
2. A Gen. 3 Hemi damper installation tool must be used to seat the seal. The appropriate installation tool may be available to rent from local auto parts retailers. Thread the damper installation tool in by hand, use a ratchet to continue to tighten the tool until you just feel the seal tool bottom out on the front cover. Ensure that the seal is square with the timing cover as it goes in.
3. Visually confirm that the seal is flush to the cover.
4. OE style dampers are shipped with a rust resistant coating on the uncoated surfaces. Remove coating using isopropyl alcohol. Lubricate the surfaces on the crank pulley that will come into contact with the crank seal using motor oil.
5. Use the installation tool to seat the damper onto the crankshaft.
6. Remove the damper install tool and install the OE damper bolt. Torque it to 129 ft./lbs.

One-piece OE style damper/pulley:

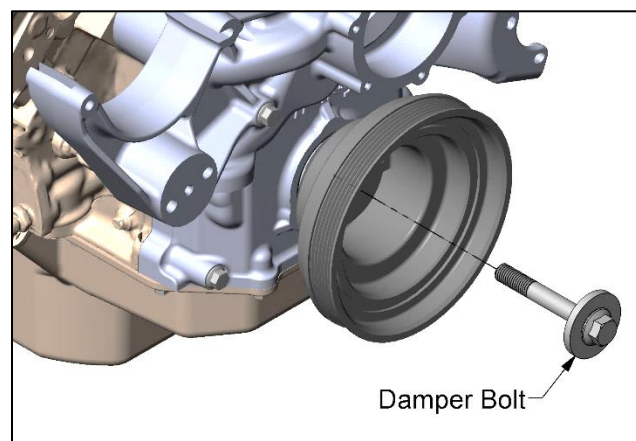

SFI certified damper and billet pulley:

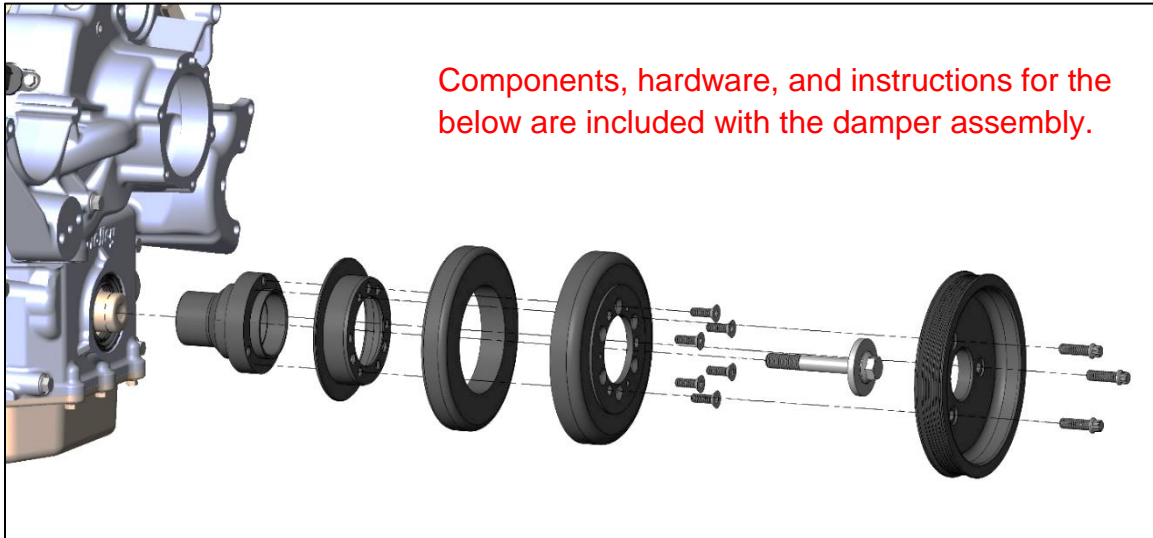

Water Pump Installation:

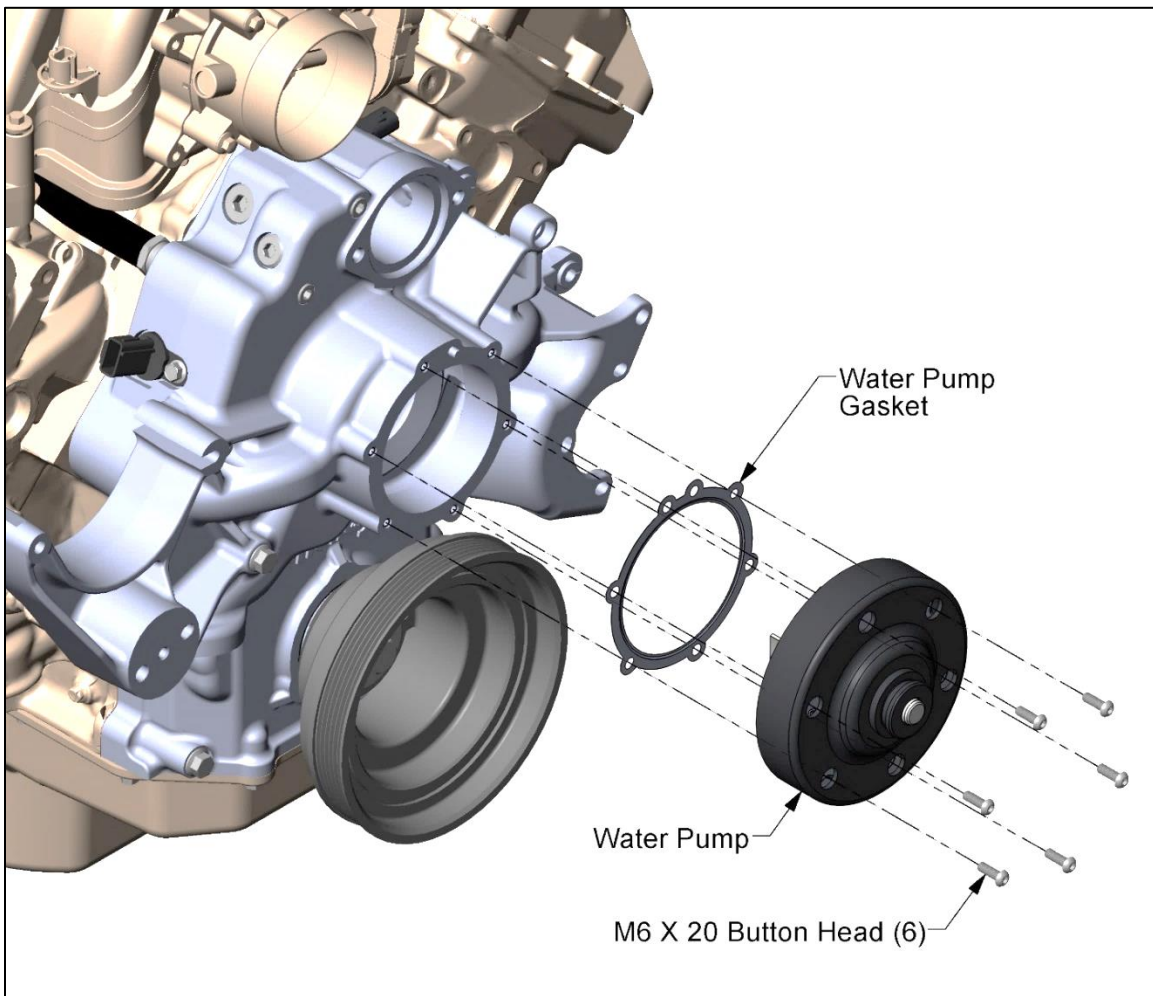

NOTE: Torque M6 bolts to 85 in./lbs.

WARNING: Do not overtighten water pump bolts.

Alternator Installation:

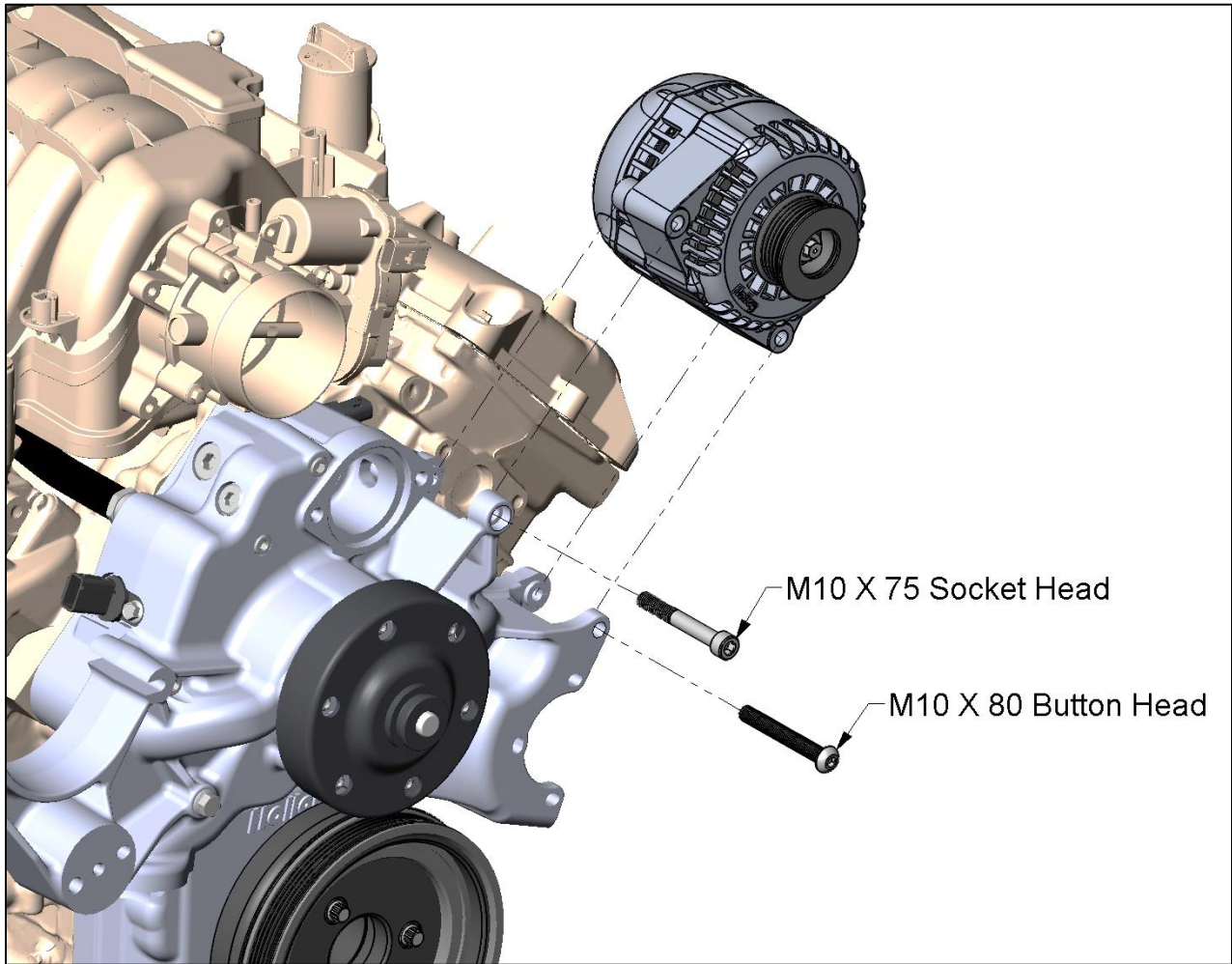

NOTE: Torque M10 bolts to 36 ft./lbs.

HELPFUL HINT: When wiring the alternator, install the included 197-400 plug into the alternator. Next, connect the yellow wire to switched voltage that is “on” when the key is in the run position. If the vehicle has a “charge indicator light”, the yellow wire can be connected to that circuit.

P/S Pump/Reservoir Installation:

Install the 198-101 power steering -6 AN adapter/tube – assemble at this time.

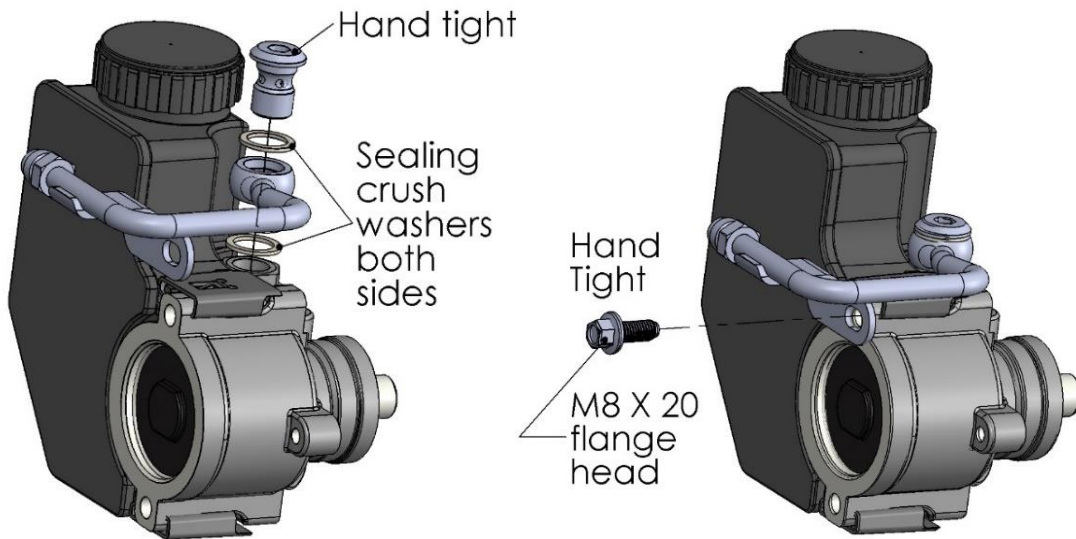

NOTE: After assembly torque M8 bolts to 18 ft./lbs. and banjo bolt to 25 ft./lbs.

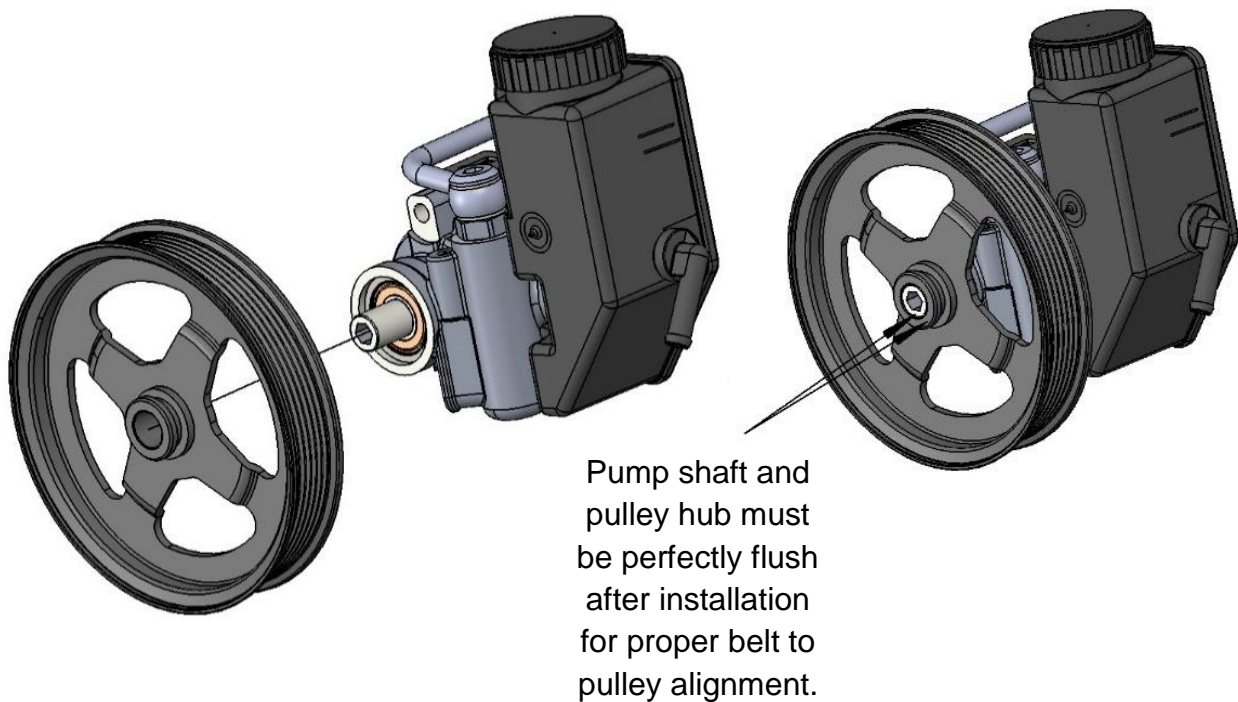

HELPFUL HINT: Pulley installation tools are available for rent at most auto parts stores.

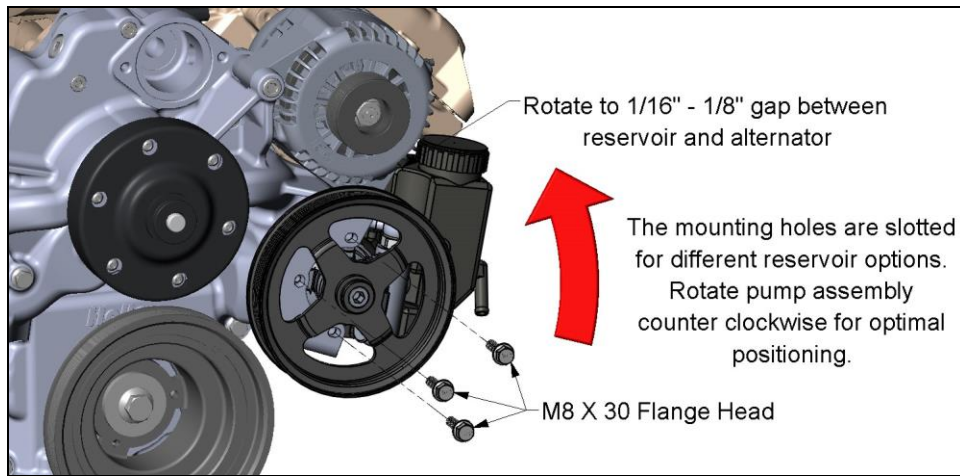

NOTE: Torque M8 bolts to 18 ft./lbs.

IF THERE IS RESERVOIR INTERFERENCE: In a few applications, the supplied reservoir may interfere with the vehicle. In these cases, use Holley P/N PS0001ERL to adapt the supplied P/S pump's inlet to a connection appropriate for use with most remote reservoirs. Reservoir options include Holley P/N 198-211 and 198-212 when used with adapter AT785010ERL.

HYDRO-BOOST BRAKE APPLICATIONS: These applications often require an additional reservoir inlet. Use PS0001ERL and AT785010ERL adapters with either 198-211 or 198-212 Holley reservoirs for these applications.

Water Inlet/Outlet Installation:

The Holley Mid-Mount allows for different water inlet and outlet options to make sourcing radiator hoses for your swap application easier. This kit includes a 45° and 90° swivel, which can be installed in either the inlet or outlet location. These are also available as accessories if two of the same angle are required. In addition to these angled adapters, the factory straight outlet adapter can be installed in either location if that better fits your application.

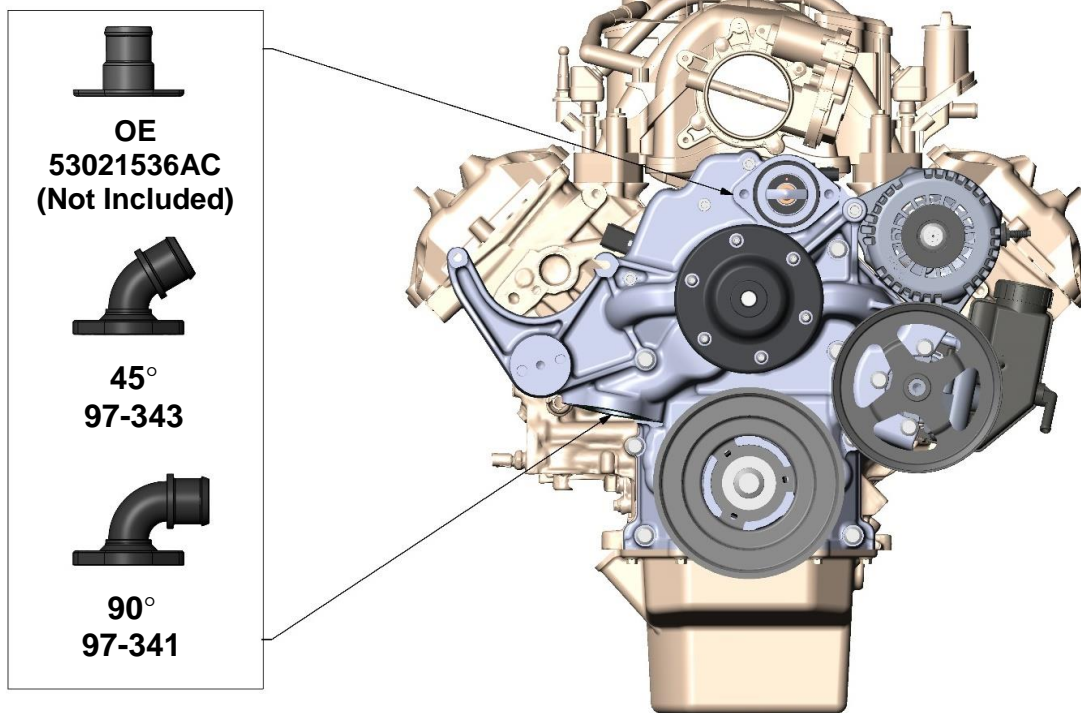

NOTE: Tighten bolts evenly to ensure an adequate seal.

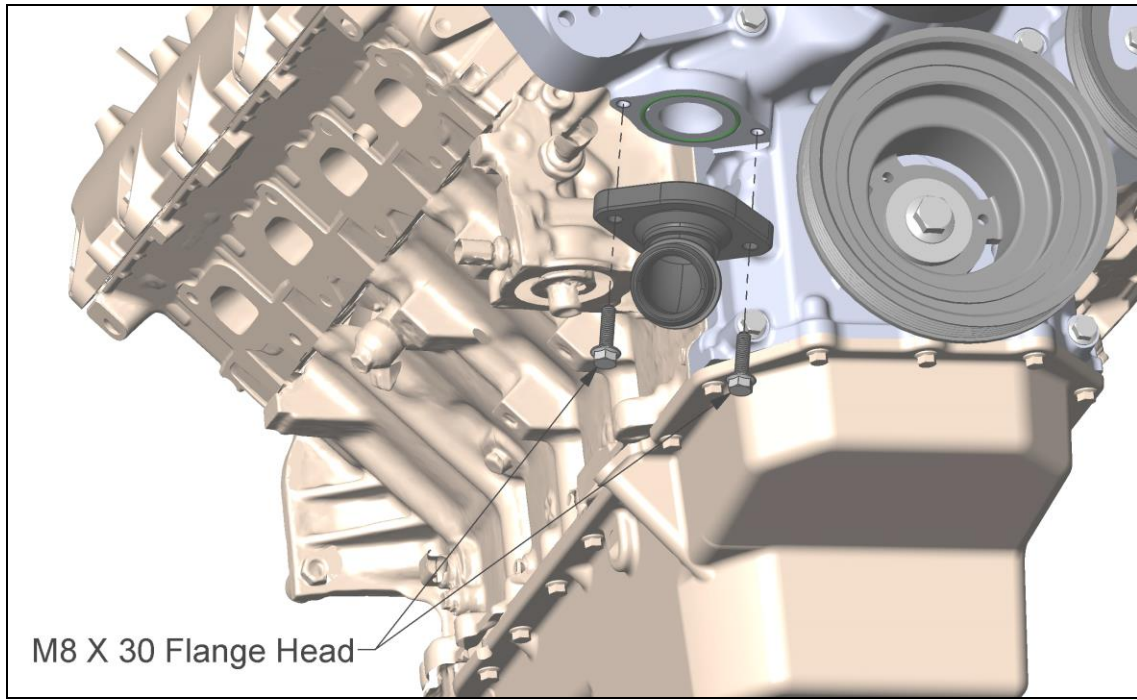

NOTE: Torque M8 bolts to 18 ft./lbs.

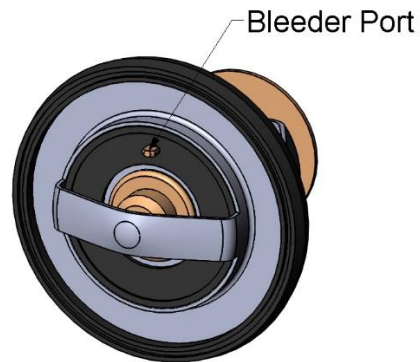

NOTE: Ensure that the thermostat is installed with the bleeder port in the 12 o'clock position

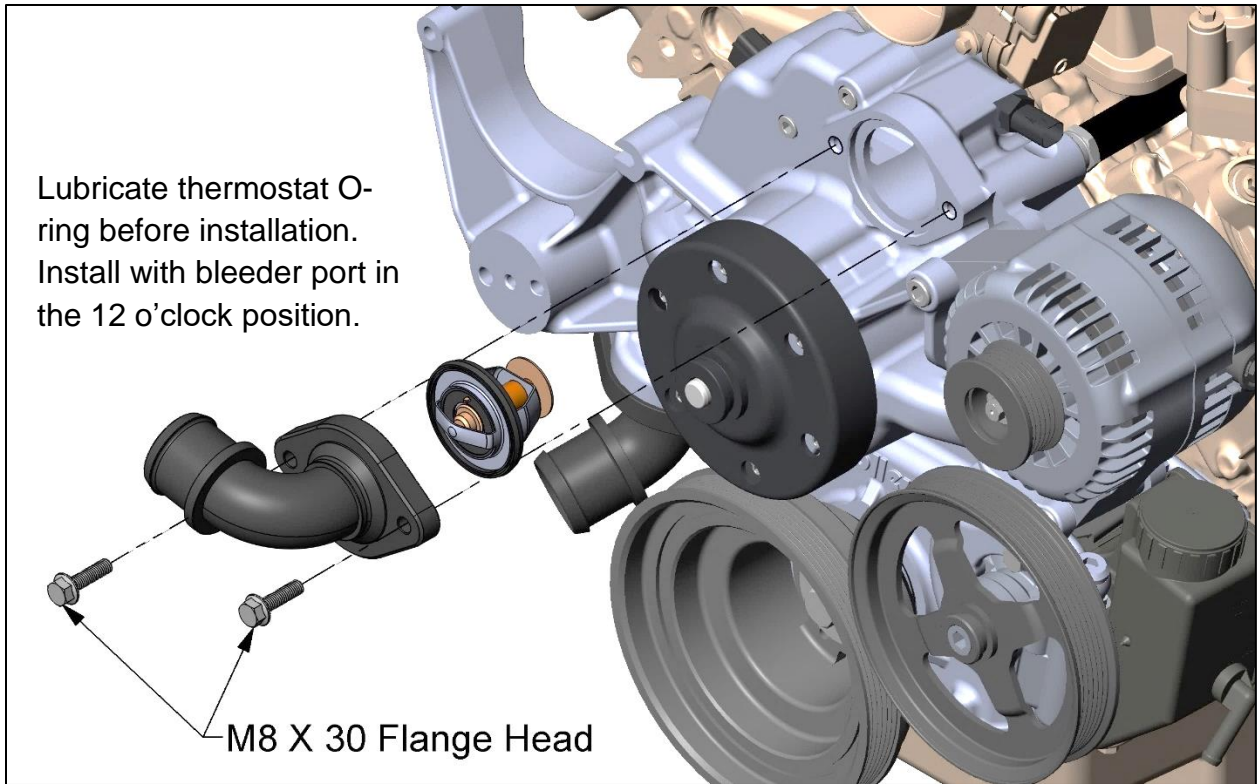

NOTE: Torque M8 bolts to 18 ft./lbs.

A/C Compressor Installation:

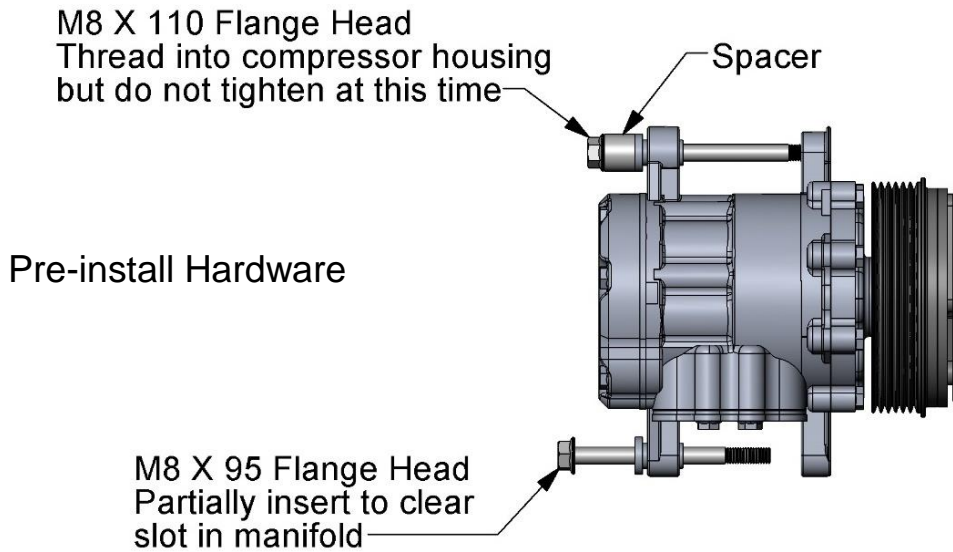

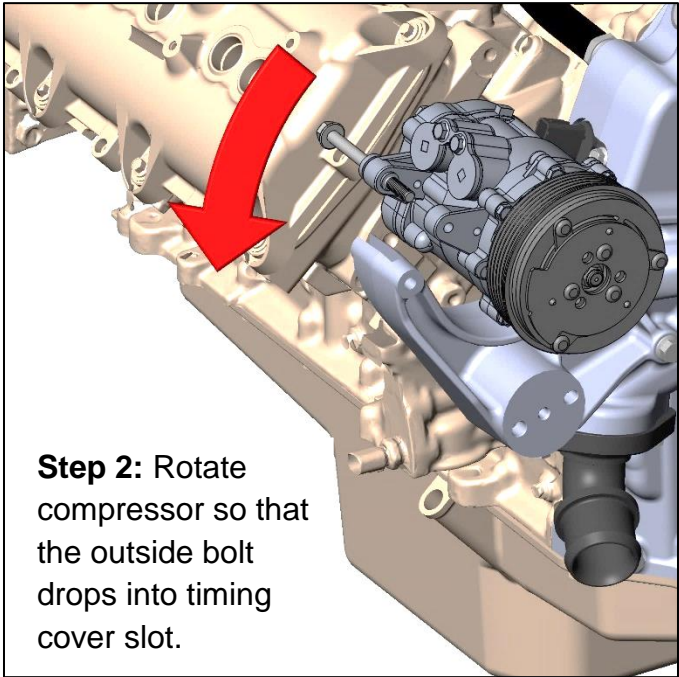
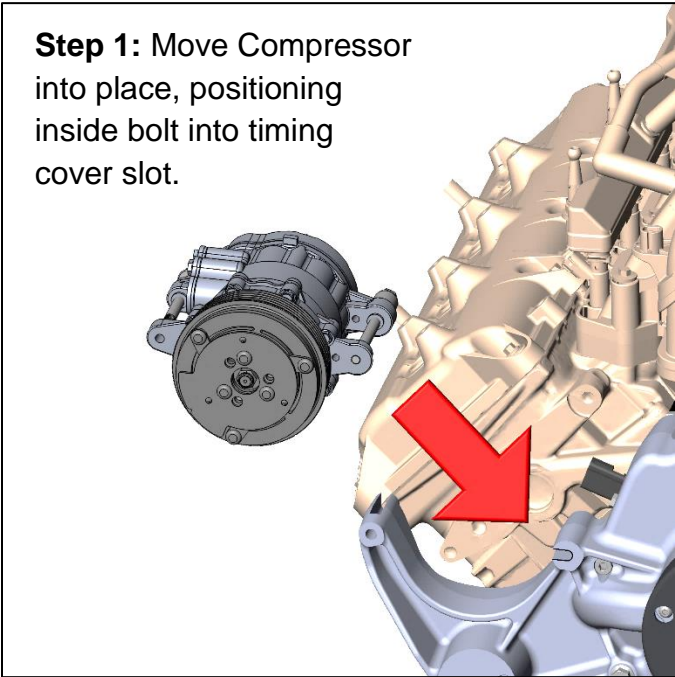

NOTE: Torque M8 bolts to 18 ft./lbs.

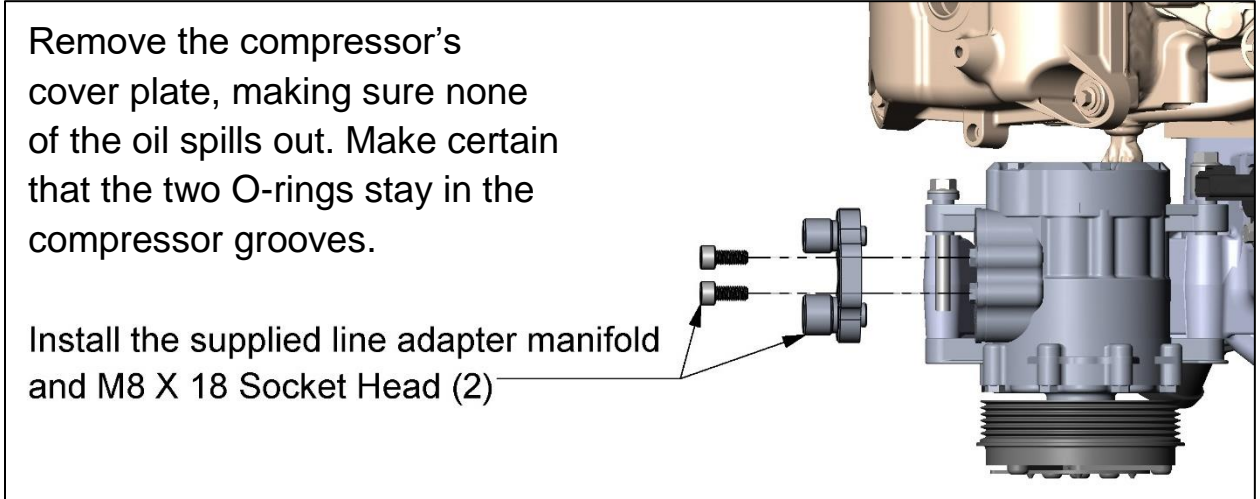

NOTE: Torque M8 bolts to 18 ft./lbs.

Belt Tensioner Installation:

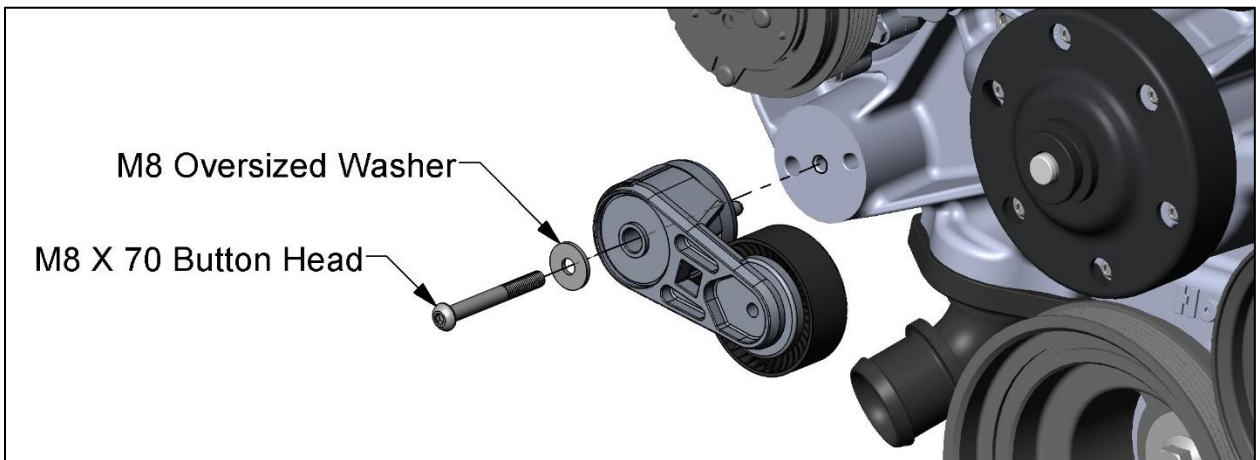

NOTE: Torque M8 bolts to 18 ft./lbs.

Belt Installation:

Route belt around pulleys as shown in red.

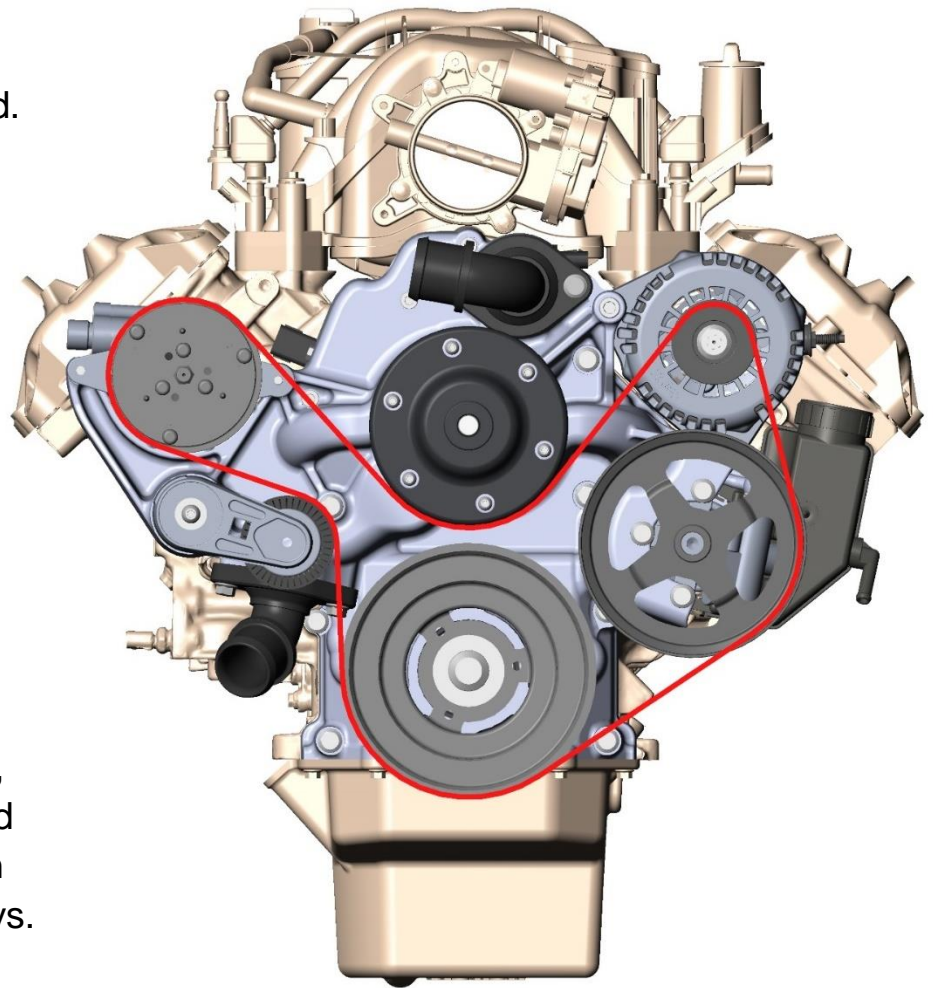

For easy installation, route onto all grooved pulleys first and then onto the smooth pulleys.

NOTE: Use supplied serpentine belt if using ALL included Holley accessories and supplemental parts.

HELPFUL HINT: When installing the belt, use a 1/2" square drive wrench to pull the tensioner all the way down, route around all the pulleys except the water pump pulley. Slip the belt on the smooth water pump pulley last.

Accessory and Tensioner Covers:

Cosmetic covers are included with some kits. If not included, these can be purchased individually. See instructions included with cover for installation procedures.

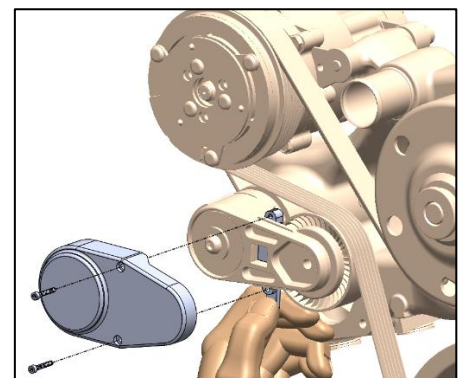
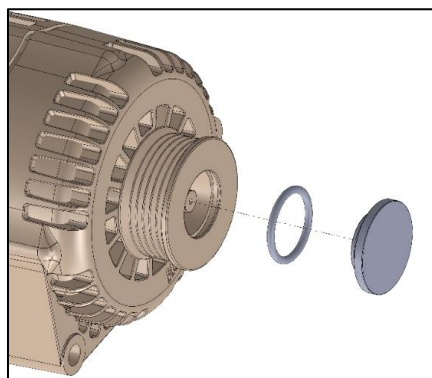
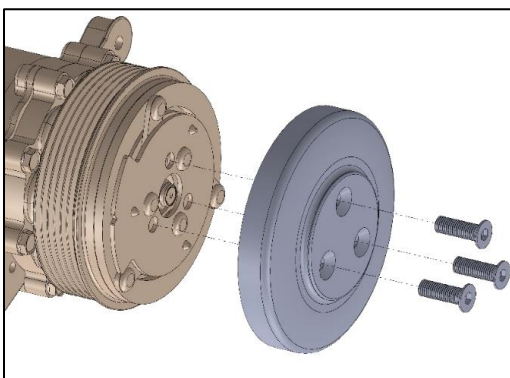

Holley® Performance Products, Inc.
1801 Russellville Road
Bowling Green, KY 42101

Technical Support: 1-866-464-6553
Phone: 1-270-781-9741
www.holley.com

© 2021 Holley Performance Products, Inc. All rights reserved. Tous Droits Réservés.

199R12056
Revision Date: 1-14-22