

**PLEASE** study these instructions carefully before beginning this installation. This installation can be accomplished with common tools and procedures. However, a familiarity with working on automotive fuel systems is highly recommended. If you do not feel comfortable performing this installation or have never worked with automotive fuel systems before, it is highly recommended to have the installation completed by a Professional Mechanic. Proper installation is the responsibility of the installer. Improper installation will void the manufacturer's warranty and may result in poor performance and engine or vehicle damage. If you have any questions, please call our **Technical Hotline at: 1-800-416-8628**, Monday - Friday, 7:00 am - 5:00 pm, Pacific Standard Time.

**WARNING!**

**Make sure to perform the installation in a well ventilated area away from any potential fire hazards. Gasoline fumes are toxic and are highly flammable. Prior to starting the installation, make sure to eliminate all potential fire hazards as fuel leakage can occur when loosening the fuel system connections.**

**DESCRIPTION**

This universal, adjustable fuel sump system will provide the necessary high fuel pressure required for most EFI applications in vehicles originally equipped with carbureted fuel systems. For ease of installation, the factory carbureted fuel system can be used in conjunction with the universal fuel sump system. This works by feeding the fuel sump at standard Carb pressure (**7 PSI max**) using the factory fuel tank and mechanical fuel pump or low pressure electric fuel pump. The sump contains a high pressure fuel pump, adjustable pressure regulator and internal bypass. This will provide the desired fuel pressure necessary to adequately operate EFI systems; all without the need for a fuel return line.

**CAUTION: Due to the high fuel pressure used by the E-Street EFI system, the supplied 3/8 inch high pressure rubber fuel line MUST be used as the primary fuel line. If supplying your own high pressure fuel line, a minimum of SAE J30R9 (100PSI) working pressure must be used. Additional fuel fittings will be required.**

**NOTE: THIS SUMP IS NOT INTENDED FOR OFF ROAD USE, ROCK CRAWLING OR APPLICATIONS WHERE VEHICLE WILL BE SUSTAINED AT INCLINE OR DECLINE ANGLES GREATER THAN 45 DEGREES FOR EXTENDED DURATIONS.**

P/N 36031 Includes (#36032 will only include the Sump Tank and harness pigtail):

- |  |   |
|--|---|
| 1. Fuel Sump Tank  | 5. -6 AN Twist-Lok Fuel Hose (8 Ft)                   |
| 2. Mounting Hardware: (3) Grommets, (3) Bushings,<br>(3) 3/4" Washers, (3) 1/4-20 x 2-3/4" Bolts, (3) 1/4-20 Nuts,<br>(3) 1/4" Washers, (3) Aluminum Spacers | 6. -6 AN Twist-Lok Hose Fitting (2 - 90°)             |
| 3. High Pressure Secondary Steel Fuel Filter w/ Mounting Clamp   | 7. Brass Compression Nut/Sleeve (1 - 3/8", 1 - 5/16") |
| 4. Fuel Sump Power Supply pigtail  | 8. Brass Tube Adapter Fitting (1 - 3/8", 1 - 5/16")   |
|  | 9. -6 AN Twist-Lok Hose Fitting, Straight             |
|  | 10. Hose Clamps (4)                                   |

**Fig. 1 - INSTALLATION DIAGRAM**

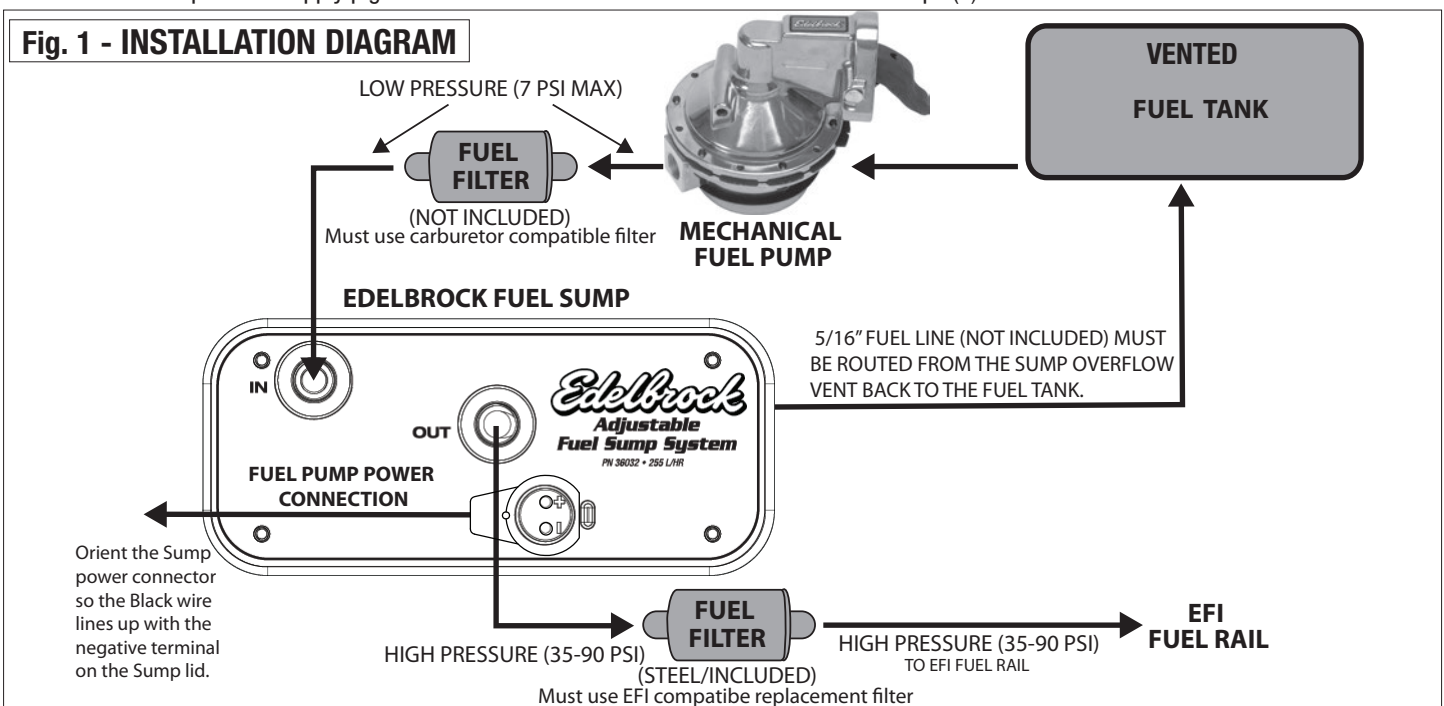

## FUEL SUMP INSTALLATION

This is a general guideline for installing the Edelbrock Fuel Sump System #36031. *If using #36032, additional hardware mentioned in these instructions (i.e. fuel lines, fuel filters, mounting brackets, harnesses and fittings) will have to be supplied.*

**NOTE:** Depending on your application and specific routing needs, additional fuel fittings may be required. These fittings are available at your local Russell Performance dealer.

1. With the ignition off and the engine cool, disconnect the NEGATIVE (-) terminal on the battery.
2. Release the fuel pressure in the fuel tank by removing the gas cap.
3. Determine the ideal mounting location for the Fuel Sump using the supplied mounting hardware and grommets. See Fig. 2 and 3 for hardware location and mounting orientation requirements.

Fig. 2



**NOTE:** In addition to the sump tank mounting points, additional mounting brackets may be required to securely mount the Fuel Sump. A full scale template is provided with these instructions for convenience.

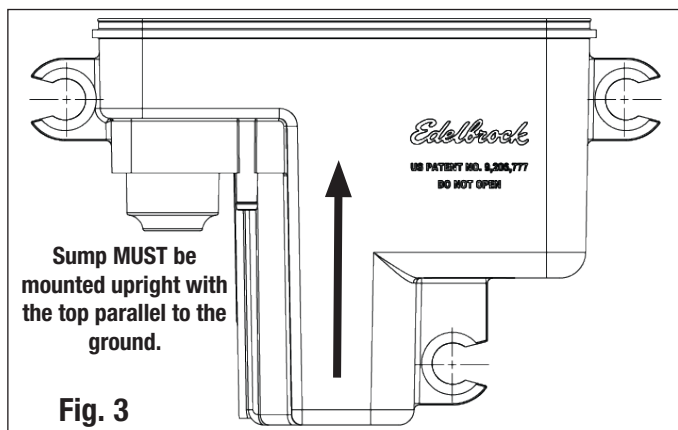

4. Remove the fuel pump output line (*mechanical pump to carburetor*) from the factory mechanical fuel pump and carburetor (*if applicable*). Use an appropriate drain pan to catch any fuel that is still in the line. Clean up any spilt fuel before proceeding.

**NOTE:** The mechanical fuel pump needs to be configured with a 3/8" barb fitting. Brass compression nuts and tube adaptors are provided for your convenience. Depending on your mechanical fuel pump configuration, additional fittings may be required.

*If using a low pressure (7 PSI MAX) electric fuel pump, the fuel pump output will route and connect to the sump inlet fitting.*

**NOTE:** Edelbrock recommends the use of a primary fuel filter (not included) placed in between the low pressure pump and the fuel sump inlet.

**DO NOT** route the fuel lines around sharp objects, moving components or exhaust manifolds/headers. **NEVER ROUTE FUEL LINES INSIDE THE VEHICLE FOR ANY REASON.**

**WARNING!** When installing the inlet and outlet fittings into the sump lid during step #5 & step #7, tighten the fittings **BY HAND** until the hex contacts the sump lid. Then, turn the fittings approximately 1/6 of a turn from 12 O'Clock to 2 O'Clock with a 3/4" wrench (see figure #3). Over or under tightening the lid fittings may cause leaks and or permanent damage to the threads in the lid.

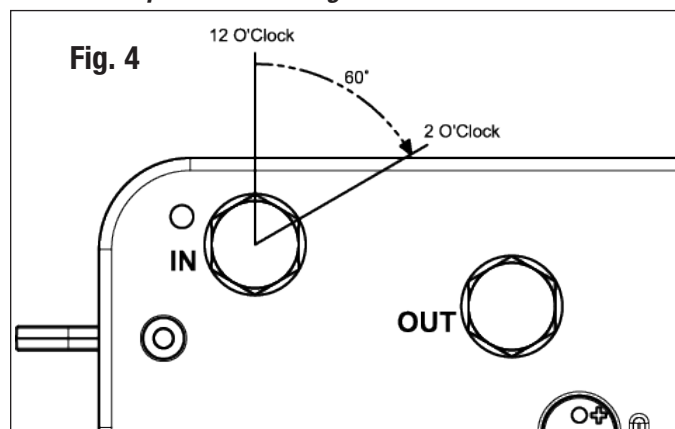

5. Assemble the Fuel Sump input line using one 90° Twist-Lok fitting and the 3/8" fuel line.

**NOTE:** Twist-Loc fittings must be installed onto the 3/8" fuel line BEFORE threading the fittings into the lid. Please refer to the Twist-Loc hose assembly procedure on page #4 of this instruction sheet.

Lubricate the fitting O-ring with silicone lube and install the 90° Twist-Lok fitting onto the "IN" fitting on top of the Fuel Sump. Route the fuel line towards the primary fuel filter (if equipped) or connect to the mechanical fuel pump fitting installed in step #4. Cut fuel line to length as needed and secure the fuel input line with a hose clamp.

**NOTE:** Twist-Loc fitting connections do not require hose clamps.

6. Determine the ideal mounting location for the secondary steel, EFI fuel filter (included) and secure using the provided mounting clamp.

**NOTE:** The secondary steel, EFI fuel filter must be used to avoid contaminating the EFI System.

7. Assemble the Fuel Sump output line using one 90° Twist-Lok fitting and the 3/8" fuel line. Install the fitting onto the fuel line first. Then, lubricate the fitting O-ring with silicone lube and install the 90° Twist-Lok fitting onto the "OUT" fitting on top of the Fuel Sump. Route the fuel line towards the secondary fuel filter. Cut fuel line to length as needed and secure the fuel output line to secondary fuel filter with a hose clamp.

- Attach the 3/8" fuel line to the Straight Twist-Lok fitting first, then connect to the fuel rail fitting on the EFI system.

**NOTE:** Additional fittings may be required depending on the EFI application used. These are available at your local Russell Performance dealer.

- Route the fuel line from the EFI fuel rail to secondary steel fuel filter, cut fuel line to length as needed and secure with a hose clamp.
- Attach 5/16" fuel hose (not supplied) to the fuel sump vent fitting and secure with a hose clamp.

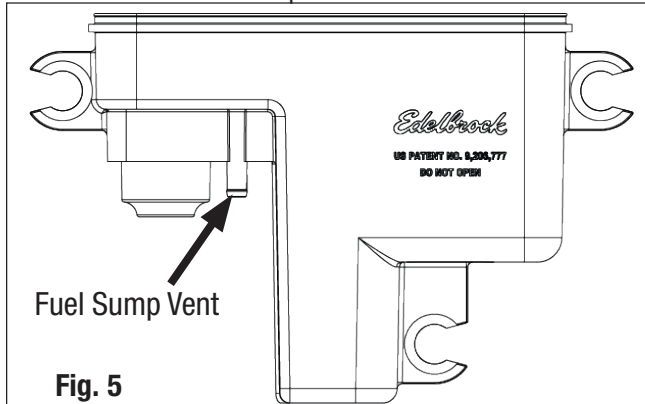

**NOTE:** The supplied 3/8" fuel hose is Twist-Lok and is **NOT** recommended for use on the fuel sump vent fitting.

- The fuel sump vent line **MUST** be routed back to the fuel tank (fuel tank must have a vent or use a vented cap).

**NOTE:** If charcoal canister has been removed, the existing hard line from the canister to the tank is convenient for use as a vent line.

**WARNING:** The following steps must be performed to properly fill the Fuel Sump prior to starting the vehicle. Failure to do so will damage the fuel pump inside the sump and void your warranty.

- Reconnect the NEGATIVE (-) terminal on the battery. Verify that the Fuel Sump power connector **IS NOT** connected to the fuel sump. Turn the key to the "ON" position and crank the engine for 10 seconds. Turn the key to the "OFF" position and wait for 30 seconds. Repeat this procedure one more time to properly fill the fuel sump.

**NOTE:** The engine will not start. If it does, it will stall as there is no fuel going into the engine. This is normal.

- Once the Fuel Sump has been filled, connect the supplied Fuel Sump pigtail to the Fuel Sump power connector (see figure 1).  
**NOTE:** The supplied Fuel Sump pigtail is designed to connect to Edelbrock EFI systems. If using a different brand EFI system, cut and splice the pigtail to an appropriate fuel pump power supply.

- Turn the key to the "ON" position but **DO NOT** start the vehicle. With the key in the "ON" position, check all fuel connections for leaks. If leaks are present, immediately turn the key off and repair all leaks before continuing.

**NOTE:** The Fuel Sump will make a pumping/priming noise for 5-8 seconds when the key is first turned on (when using Edelbrock EFI systems). If Fuel Sump is not priming, verify that the Fuel Sump harness is installed correctly.

- If the Fuel Sump is priming, the Fuel Sump installation is complete.

**Fuel Pressure Regulator Adjustment:** The fuel sump is factory set to 58 psi. Adjust the fuel pressure by loosening the jam nut on the regulator with a 9/16" wrench. Tighten the adjuster screw with a 7/16" wrench to raise the fuel pressure or loosen the adjuster screw to lower the fuel pressure. When the desired pressure is met, tighten the jam nut (snug) while holding the adjuster screw in place. (See figure #5 for reference)

**IMPORTANT:** If your application has the fuel injectors located under the throttle blades or in the manifold ports like a Pro Flo system, it is recommended that the fuel regulator on the Edelbrock Fuel Sump is vacuum compensated. The proper vacuum compensation connection for the Edelbrock Fuel Sump Bypass Regulator requires a length of 5/32" vacuum line to be routed from the intake manifold plenum, after the throttle body, to the port on the Fuel Pressure Regulator Adjustment Fitting. Be certain to set base fuel pressure with the vacuum/boost line disconnected while the engine is running. If the injectors are located above the throttle blades as with some TBI systems, leave the regulator port on the fuel sump open to atmosphere.



### **WARNING!**

The fuel sump vent line is a critical part of the Fuel Sump installation. These instructions **MUST** be followed for safe and proper system operation. A fuel rated hose must be routed from the vent port (see figure #4) back to the fuel tank. The fuel tank must also be vented if not originally equipped with a vent line or vented cap. If the vehicle has a vent line, you can tee into this line. If no existing vent line to the fuel tank exists, you must plumb a new line to a point above the maximum fuel level of the tank (at the top) or in the fill neck. **DO NOT** run a vent line from the Fuel Sump to OPEN AIR in the engine compartment or pointed to the ground. **DO NOT** run the vent line into any part of the air intake system. **Proper routing of the vent line is not an option.** This procedure is mandatory for your safety. Edelbrock is not responsible for any fires, personal injuries, property damage or any other issues pertaining to improper vent line routing and or failure to follow these instructions.

## TWIST-LOC HOSE ASSEMBLY

1. Protect the Twist-Loc fitting finish by wrapping the hex with painters tape or equivalent and secure the fitting in a vice as shown below.



4. While the hose end is hot, push the hose onto the fitting using one, quick motion to fully seat the hose on the fitting so it reaches over both fitting barbs. If the hose is fully seated on the fitting, proceed to step #6.



2. Lubricate the barbed end on the fitting with silicone lube as well as the inside of the hose end that will mate with the fitting.
3. Use a heat gun to heat the end of the hose that will mate to the fitting. Rotate the hose slowly to make sure that the hose is heated evenly. Be careful not to overheat or burn the hose. If light smoke is visible, stop heating the hose and proceed to step #4.



5. If the hose is not able to be pressed onto the fitting, repeat step #3 and try again. If the hose is only able to be partially installed on the fitting, remove the hose by cutting it with a razor blade parallel to the fitting. Trim the hose end to remove the cut left by the razor blade and go back to step #3.
6. Allow the new assembly to cool before proceeding to the next step in the main instruction sheet.



**WARNING! DO NOT GRAB THE HOSE BY THE HEATED END FOR ANY REASON.**



**Edelbrock LLC • 2700 California St. • Torrance, CA 90503  
Tech-Line: 800-416-8628**

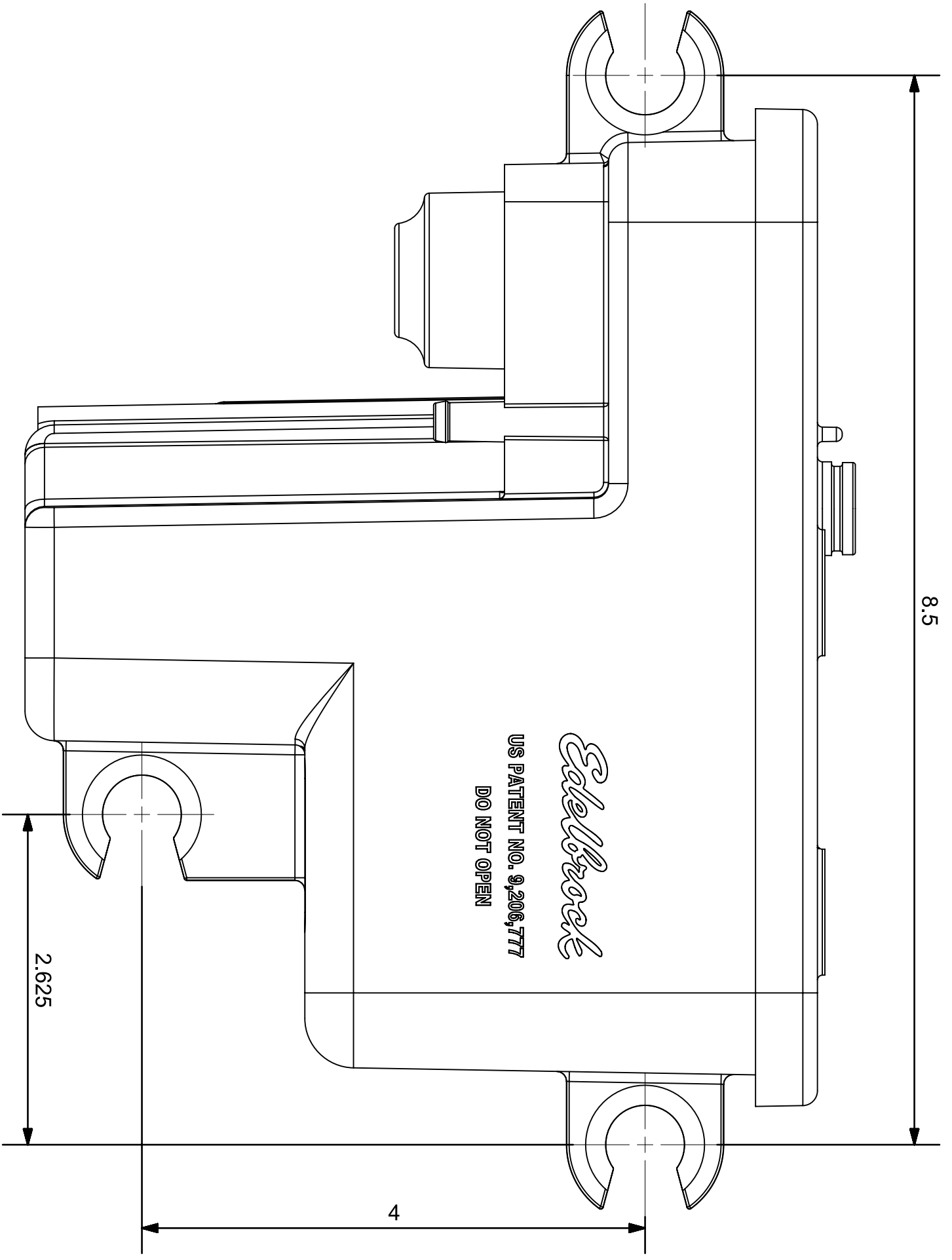

8.5

*Edelbrock*

US PATENT NO. 9,206,777

DO NOT OPEN

4

2.625

NOTE: DIMENSIONS ARE IN INCHES

