



**KC09106**  
**2007-12 DODGE NITRO,**  
**2008-12 JEEP LIBERTY 2WD & 4WD**  
**2" FRONT & REAR LEVELING KIT**



[www.Daystarproducts.com](http://www.Daystarproducts.com)

Tech Support Contact Info

[Tech@DaystarWeb.com](mailto:Tech@DaystarWeb.com)

Phone: 623.907.0081

Fax: 623.907.0088

841 South 71<sup>st</sup> Avenue

**Instruction Sheet P11257-02**  
**2007 Daystar Products International Inc.**

## **Thank you for choosing Daystar Products**

Daystar recommends a certified technician install this system. In addition to these instructions, professional knowledge of disassembly/reassembly procedures as well as post installation checks must be known. Attempts to install this system without this knowledge and expertise may jeopardize the integrity and/or operating of the vehicle.

Please read all the instructions before beginning the installation. Check the kit hardware against the parts list. Be sure you have all the needed parts and understand where they go. If anything is missing, do not proceed with the installation, call Daystar Products to obtain any needed items.

### **Product Use Information**

As a general rule, the taller a vehicle is the easier it will roll. We strongly recommend, because of rollover possibility, that seat belts and shoulder harnesses be worn at all times. Avoid situations where a side rollover may occur.

Braking performance and capabilities are decreased when significantly large/heavier tires and wheels are used. Take this into consideration while driving. Also, speedometer recalibration is necessary when larger tires are installed.

Do not add, alter, or fabricate any factory or after-market parts which increase vehicle height over the intended height of the Daystar Product purchased. Mixing component brands, lifts, and/or combining body lift with suspension lift voids all warranties. Daystar makes no claims regarding lifting devices and excludes any and all implied claims. We will not be responsible for any products that is altered.

### **Notice to Dealer and Vehicle Owner**

Any vehicle equipped with any Daystar Product must have the “Warning to driver” decal installed on the sun visor or dash. The decal is to act a constant reminder for whoever is operating the vehicle of its unique handling characteristics. INSTALLING DEALER— Its is your responsibility to install the warning decal and forward these instructions on to the vehicle owner for review and to be kept in the vehicle for service life.

After installation occurs, a qualified alignment facility is required to align the vehicle to factory specs.

**IMPORTANT NOTE:** The advertised amount of lift that this kit provides and the thickness of the spacers supplied will not be the same! For example, a 2-1/2” lift may only have 1-1/2” thick spacers. The reason for the difference between the spacer thickness and the amount of lift has to do with suspension geometry. There is a ratio involved, and it is this ratio that determines the thickness of the spacers. Rest assured, installing the spacer supplied will result in the proper amount of lift out at the wheel.

## Installation steps

1. Place the vehicle on a level and clean work service.
2. Read the instructions carefully.
3. Open the hood of the vehicle.
4. Working on the driver side of the vehicle, disconnect the battery pinch clamps ( 1,6 ) and remove the thermal guard (7) around the battery. Remove the battery hold down clamp (2,3) and remove the battery (5) from tray(4).

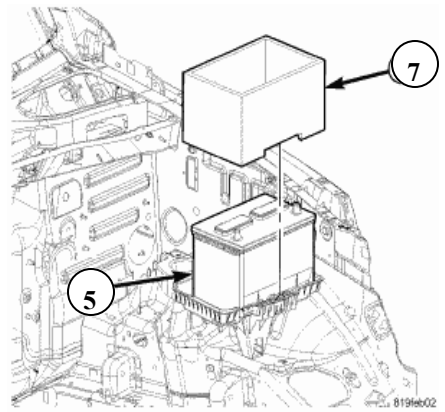
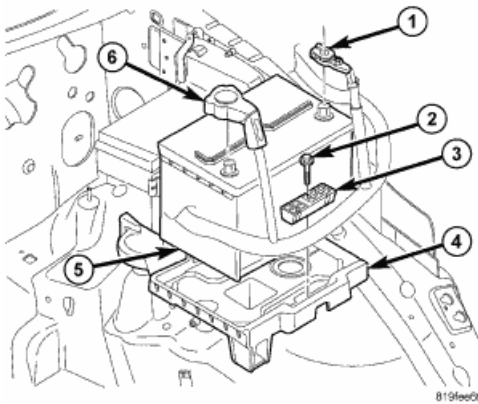

5. Disconnect the power lead (2) to the totally integrated power module (TIPM 3) by opening the cover (4) and remove the nut with a 11mm socket (1).

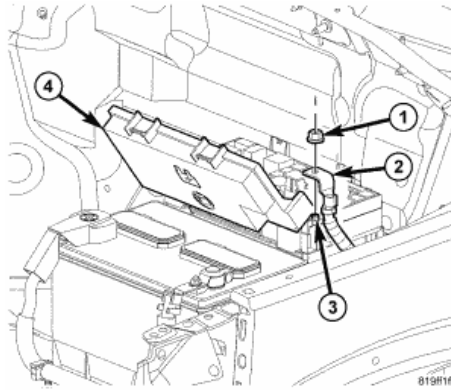

6. Disconnect the purge solenoid (1) from the battery tray (2) by pulling up on the solenoid and push away from the tray.

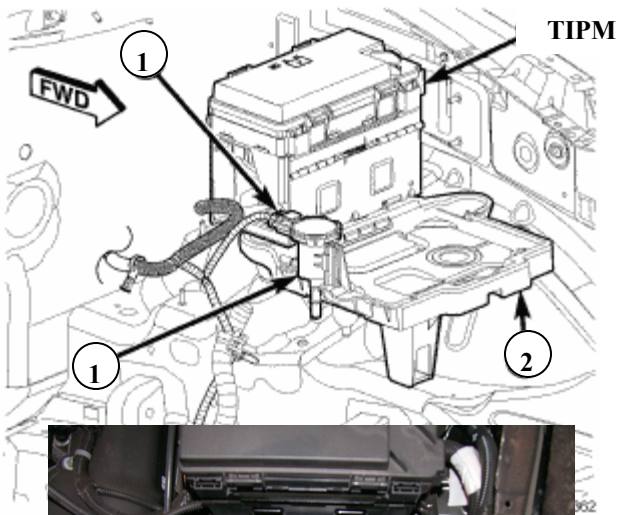

- Using a appropriate flat bladed tool, depress the four mounting clips ( 3 ) to disengage and remove the TIPM housing (1) from the TIPM bracket ( 2 ) mounting tabs.

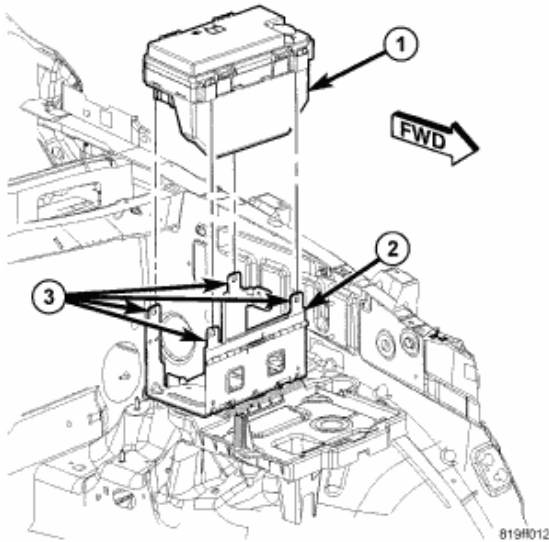

- Disconnect each of the seven TIPM wire harness connectors from the TIPM housing. NOTE: Take care when removing the connectors.

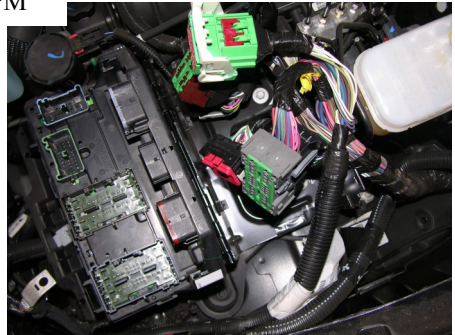
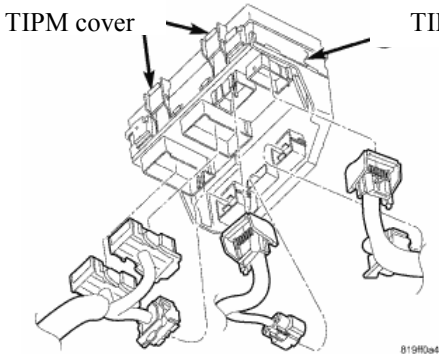

- Remove the TIPM and put it in a safe place.

10. Remove the TIPM bracket retaining screws (1) with a 12mm socket and slide the bracket (2) rearward to disengage the mounting tabs (3). Remove the TIPM bracket from the battery tray (4).

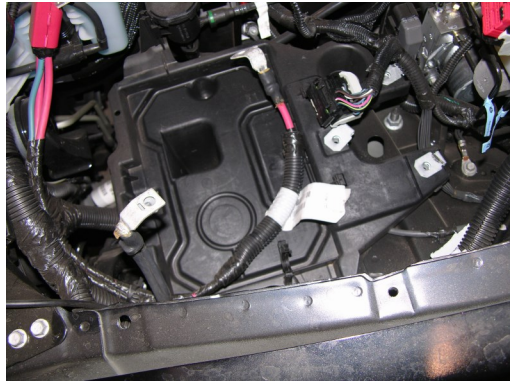
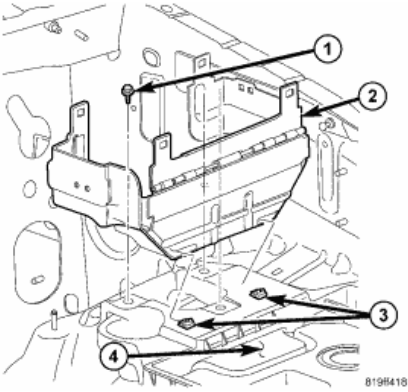

11. Remove the three nuts (1) securing the battery tray (2) to left inner fender (3). Lift the battery tray (2) out of the engine compartment and remove from the vehicle.

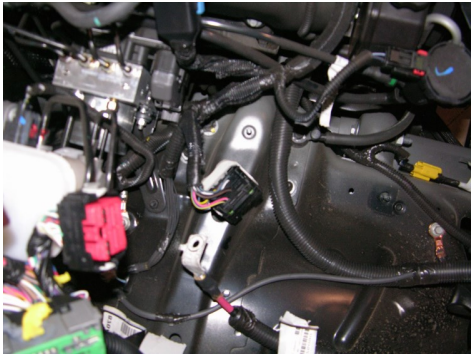
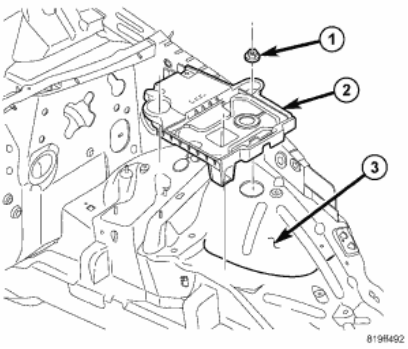

12. Remove the axle vent tube and ground wire from the 2 strut studs.

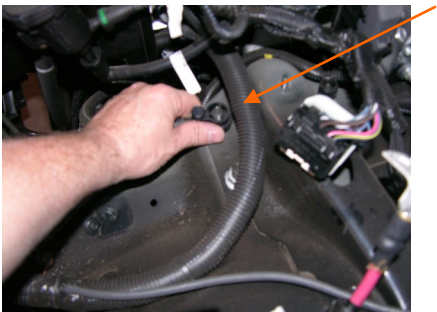

13. Working on the right side of the vehicle
14. With a flat head screw driver lessen the clamp ( 2 ) for the air intake hose (1).
15. Pry up spring clips (4) from the front of the housing cover ( spring clips retain cover to housing ).
16. Release housing cover (3) from the 4 locating tabs on the rear of housing, and remove cover and disconnect the hose at the back of the air cleaner led. Remove the air filter and pull up on the bottom air cleaner housing to remove it.

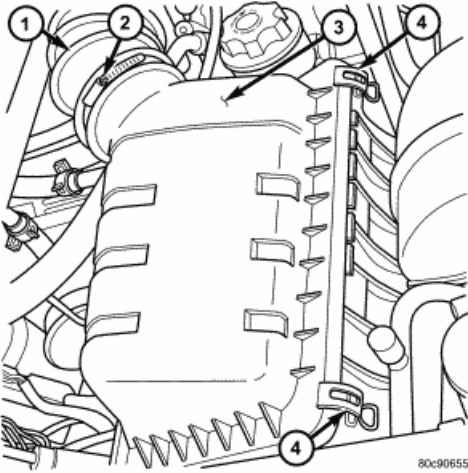

17. Place a floor jack under the vehicle and jack up the front enough to secure the vehicle on jack stands. Place wheel blocks behind the rear wheels.
18. Disconnect the sway bar end link from the lower control arm with a 18mm socket.

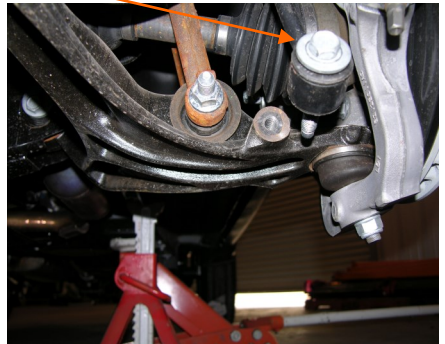

19. Remove the lower bolt at the lower control arm securing the clevis bracket with a 24mm socket.

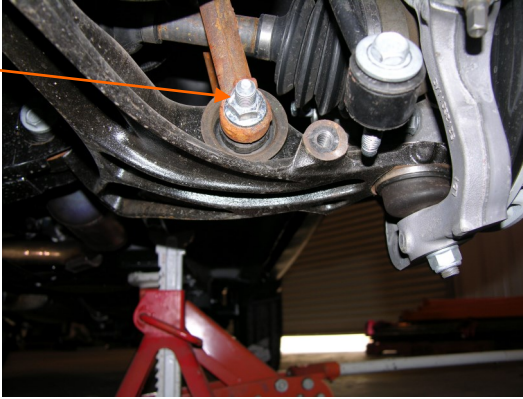

20. Remove the upper control arm ball joint nut with a 21mm wrench and separate the upper ball joint from the knuckle.

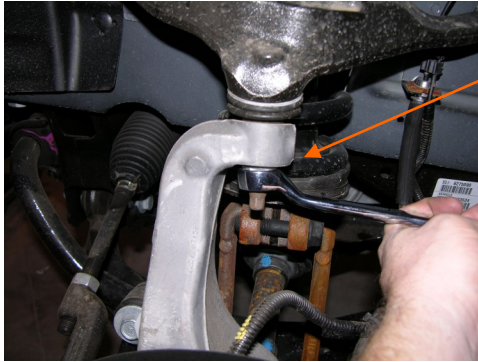

21. Pull downward on the knuckle to allow access to the strut.  
22. Remove the strut clevis bolt (2) with a 24mm socket and separate the clevis (3) from the strut assembly (1) with a pry bar.

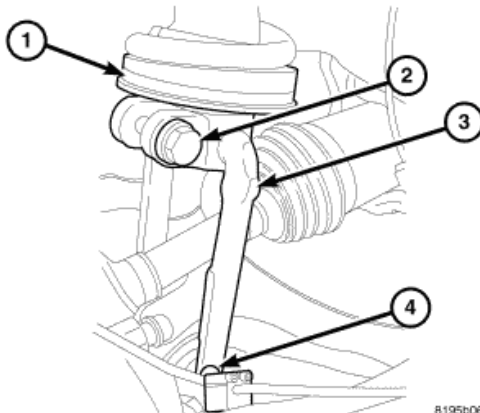



23. Remove the 4 upper strut nuts and remove the strut from the vehicle.



24. Place the strut in a wall mounted spring compressor.

25. Compress the strut and remove the upper strut nut with a 12mm socket. Remove the upper strut plate and isolator from the strut and pull the strut down from the bottom of the coil spring. Remove the lower stock spring isolator from the strut.



26. Remove the dust cover and washer from strut shaft.



27. Install the spring spacer onto the strut, note the location of the spacer bump stop on the side of the spacer, as it needs to face out ward on the strut. There is a notch on the spacer that will match a locator on the strut.



28. Install the boot over the strut and with one of the replacement washers, pull the boot over the washer at the top of the strut and zip tie the boot to the bottom of strut.



WASHER

ZIP TIE

29. Press out the stock upper strut plate studs and press them into the lift strut plate. Note that the plate matches what strut that you are working on. There are LT and RT side plates.



30. Place the stem cushion ( bevel up ) on top of the washer that is on the strut and install the strut in to the spring from the bottom. Place the stock spring isolator on the top the coil spring and follow by the replacement upper strut plate. Place the stem cushion ( bevel down ), washer and nut onto the strut plate. Note that the Keyway present on the lower portion of the strut ( this keyway locates the strut's clevis) aligns with the upper strut mounting plate studs for reassembly; the keyway faces outward as does the wide set of upper studs. Tighten the upper strut nut with 12mm socket and remove from strut compressor.



31. Reinstall the strut assembly into the vehicle and start the upper nuts, hand tighten only. Reinstall the lower strut clevis and hand tighten the bolt at the strut. Install the lower clevis bolt into the lower control arm.



32. Tighten the clevis bolt with a 24mm socket to factory specifications.
33. Place the floor jack under the lower control arm and jack up. Pull down on the upper control arm to reinstall the ball joint and nut into the knuckle. Tighten the ball joint nut with a 21mm wrench.

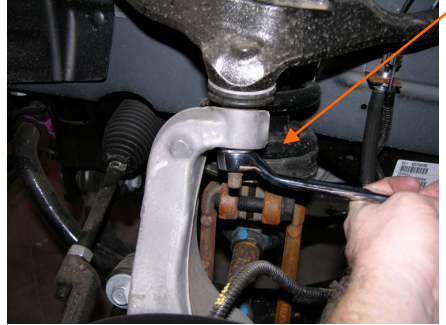

34. Repeat sets 18 though 33 on other side.
35. After both front lift spacers have been installed, reinstall the sway bar end link with a 18mm socket and tighten. Double check all fasteners for proper torque.
36. Reinstall the front tires/wheels and lower the vehicle to the floor. Tighten the upper strut nuts with a 18mm socket.

### **Rear installation**

37. Disconnect the rear lower shock bolts with a 16mm wrench and a 18mm socket.



38. Disconnect the lower sway bar end link nut with a 16mm wrench.

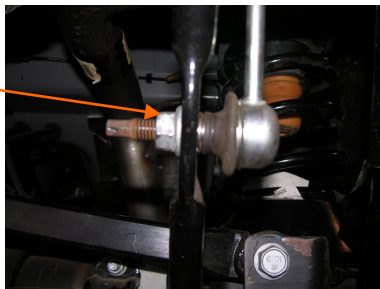

39. Jack up the rear suspension and secure the vehicle on jack stands. Leave the jack under rear axle and remove the tire/wheels. Lower the axle down to remove the coil spring.
40. Remove the lower stock spring isolator. Place the lift spacer on the lower spring mount, then reinstall the spring on top of the spacer.

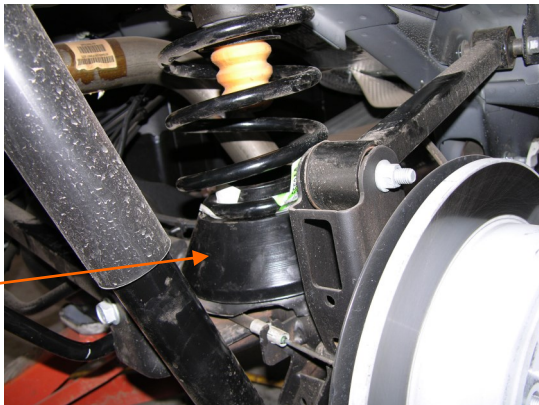

41. Reinstall the tires/wheels and lower the vehicle to the floor.
42. Reconnect the lower shock bolt/nut with a 16mm,18mm wrench and reconnect the sway bar end link.

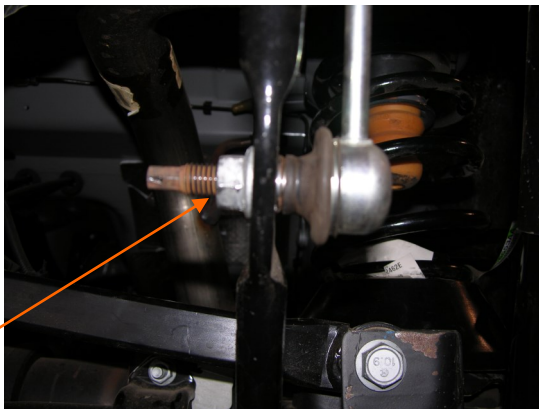

- NOTE: Double check that all the upper strut mounting nuts are tightened to factory spec.
42. Reinstall the air cleaner assembly on the right side, follow steps 13 to 16 working in reverse order.



43. Reinstall the TIPM and battery on the left side of the vehicle by following steps, 4 to 12 . Working in reverse order.

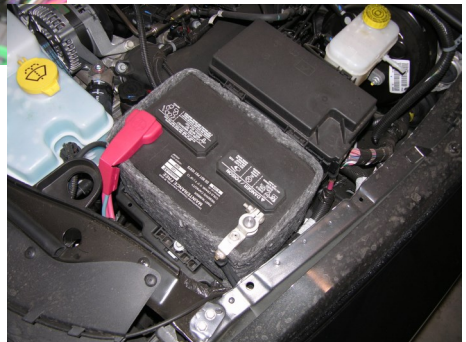

44. Start the vehicle and check and see that every thing is working correctly.
45. Alignment must be performed by a certified professional.
46. Max tire size is a 31” tire overall diameter.

AFTER

BEFORE



**Bill of Materials 2”**

Part No.	Description	Qty
M03323	Coil Spacer Ft	2
M03441	Stem Cushions	4
S10578	Left Mount plate	1
S10579	Right Mount plate	1
S10138	Washer	4
M00313	Boot	2
P01055	Cable tie	2
REAR SPACER		
M03784	Coil Spacer rear	2

**TOOLS NEEDED**

Description	Qty
Flat screw driver	1
Hammer	1
Pry Bar 15”	1
10mm socket	1
12mm socket	1
13mm socket	1
15mm socket	1
16mm socket	1
18mm socket deep	1
21mm socket deep	1
16mm wrench	1
18mm wrench	1
Wall mounted spring compressor	1
Floor jack	1
Jack stands	2