



PART NUMBER **D440-0122**

APPLICATIONS:

2017-19	F22/F23	M240i & xDrive
2016-18	F30	340i & xDrive
2016-19	F34	340i & xDrive
2017-19	F32/F33/F36	440i & xDrive
2017-19	G30	540i & xDrive
2018-19	G32	640i & xDrive GT
2016-19	G11	740i & xDrive

Congratulations for being selective enough to use a DINANTronics Elite Performance Tuner. We have spent many hours developing this system to assure that you will receive maximum performance and durability with minimum difficulty in installation.

Please take the time to read these instructions thoroughly before proceeding. When performing the installation, read the entire numbered instruction before working on the car. If you feel that you do not have the requisite skill, please arrange for a qualified repair facility to perform the installation.

**** WARNING ****

NOTE: This kit does not fit all combinations of vehicles & engines. Please pay careful attention to the vehicles listed above. Do not install this kit if your specific vehicle configuration is not shown. For any questions about compatibility, please contact DINAN at 800-341-5480.

**** PREPARE VEHICLE FOR INSTALLATION ****

During DINANTRONICS ELITE installation, the engine computer (ECU) will be disconnected from the vehicle. If the ECU is awake when it is disconnected, faults may be stored and the check engine light could be illuminated after installation. The vehicle may not function properly. To prevent this occurrence, it is essential to prepare the car correctly per the following procedure:

1. Park vehicle at the location where you will be installing DINANTRONICS ELITE.
2. Determine the range of the keys.
 - Step away from the vehicle and attempt to lock or unlock the car using the remote.
 - Continue to move away until the car no longer responds to the key. This is the range of the key.
 - During DINANTRONICS ELITE installation, ALL keys must be completely outside this range. If a key remains within range of the car, the vehicle may respond to the key and awaken unexpectedly, which could result in a stored fault and check engine light.
3. Unlock the car and open both the hood and trunk.
4. Close all the doors.
5. Move all keys beyond the range of the car.
6. After approximately one minute, you can hear the electronics in the engine compartment power down. This indicates that the electronics have gone to sleep. If you should miss this event, you can wait five minutes, which ensures that all the electronics are asleep.
7. Disconnect negative terminal of battery.
8. Install the DINANTRONICS ELITE harness and ECU per the instructions below.
9. Note that the DINANTRONICS ELITE ECU has a serial number located on a label at the side of the ECU, as well as extra labels included in the kit. After installation is complete, please visit <http://decus.dinancars.com/elitev2> to register your product. The serial number and product ID shown on these labels will be required.

DINANTronics Elite INSTALLATION:

1. Read through the subsequent steps to familiarize yourself with the installation procedure.
2. Examine the DINANTronics Elite harness supplied with this kit. There are two legs to this harness, which are similar to each other.
3. DINANTronics Elite attaches to two sensors on top of the engine.
 - A = Charge Pipe Pressure Sensor (3-pin)
 - B = Manifold Pressure Sensor (4-pin)

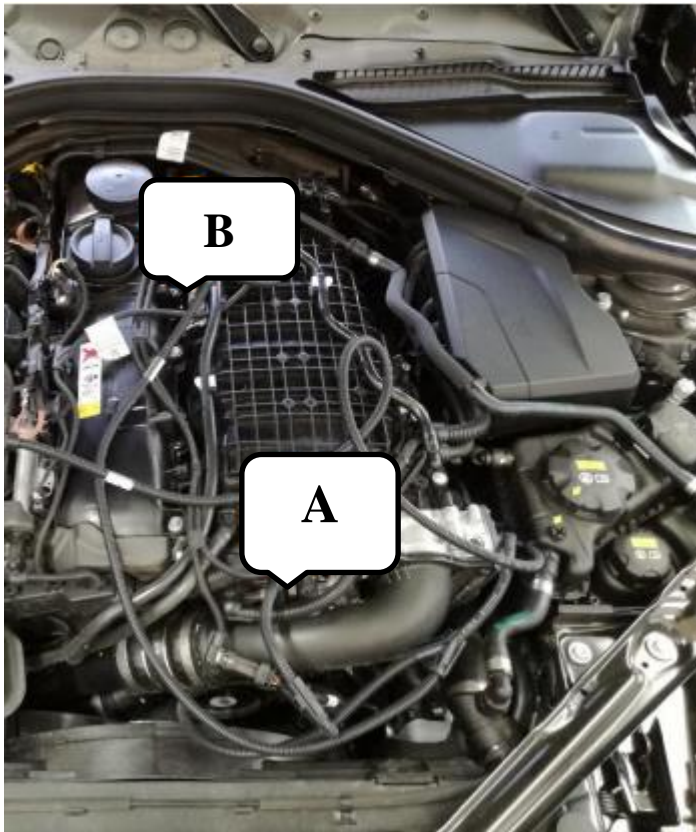

4. If removal of the engine cover is necessary to access the sensors:
 - Expose & unfasten the mounting bolts. Set hardware aside and remove engine cover.
 - Some covers are clipped into place. In this instance, simply tug upwards on the cover to release the clips, and set cover aside.
5. Study the locking system on the new DINANTronics Elite connectors until you are familiar with how the two connector halves are released. Some locks will require the use of a small flat blade screwdriver to release the tang.

**** WARNING **** -- If care is not taken, these connectors can be forcibly installed upside down, which will cause engine running problems.

- When oriented correctly, the two connectors will slide on smoothly and latch easily.
- When oriented incorrectly, you will feel resistance as the two halves come together.

Examine the connectors on the DINANTronics Elite harness, and the figure below, to understand the proper attachment of these connectors. **Notice that the "block" on the large connector must NOT be aligned with the locking mechanism of the small connector.**

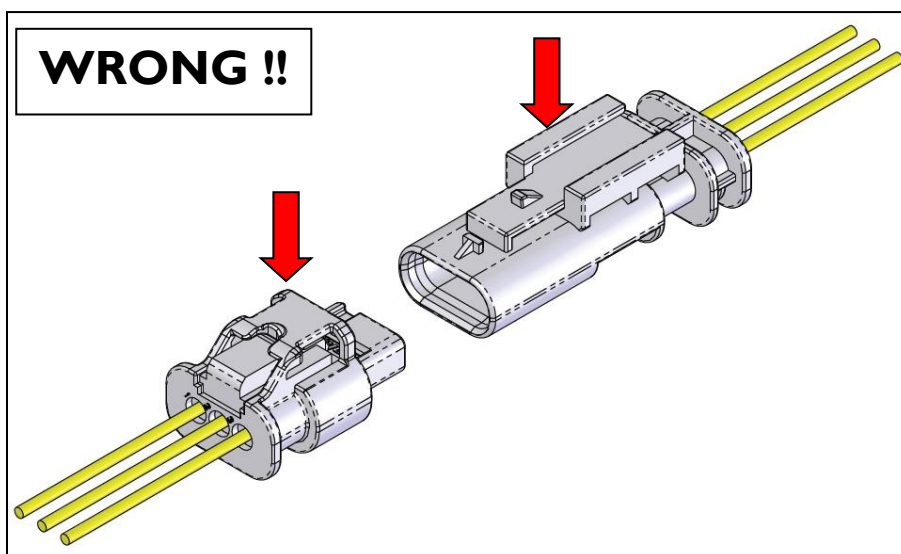
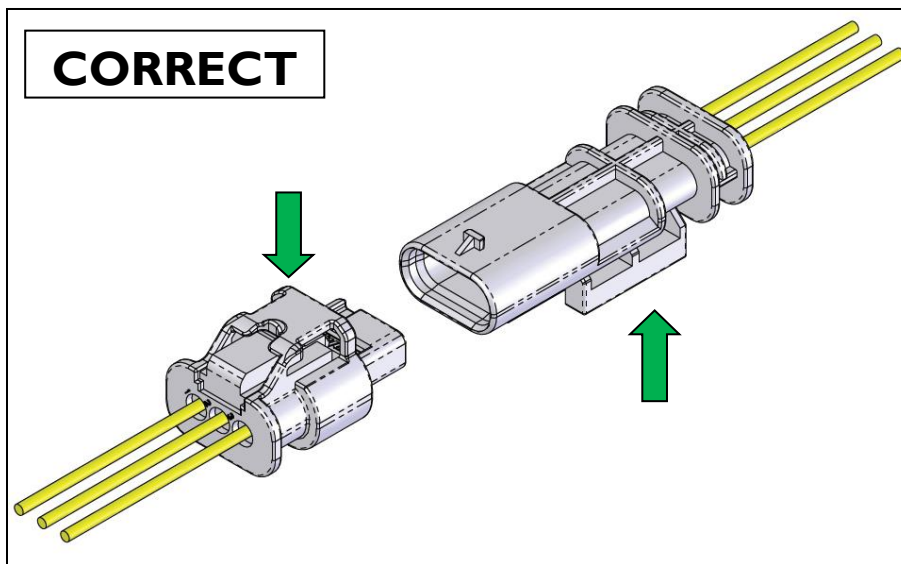

6. Disconnect the factory wiring harness from each sensor.

7. Install the DINANTronics Elite harness between the sensor and the factory harness. Ensure that the locking tangs on both connectors are secure.

7.1 Location of Sensor A: Charge Pipe Pressure Sensor

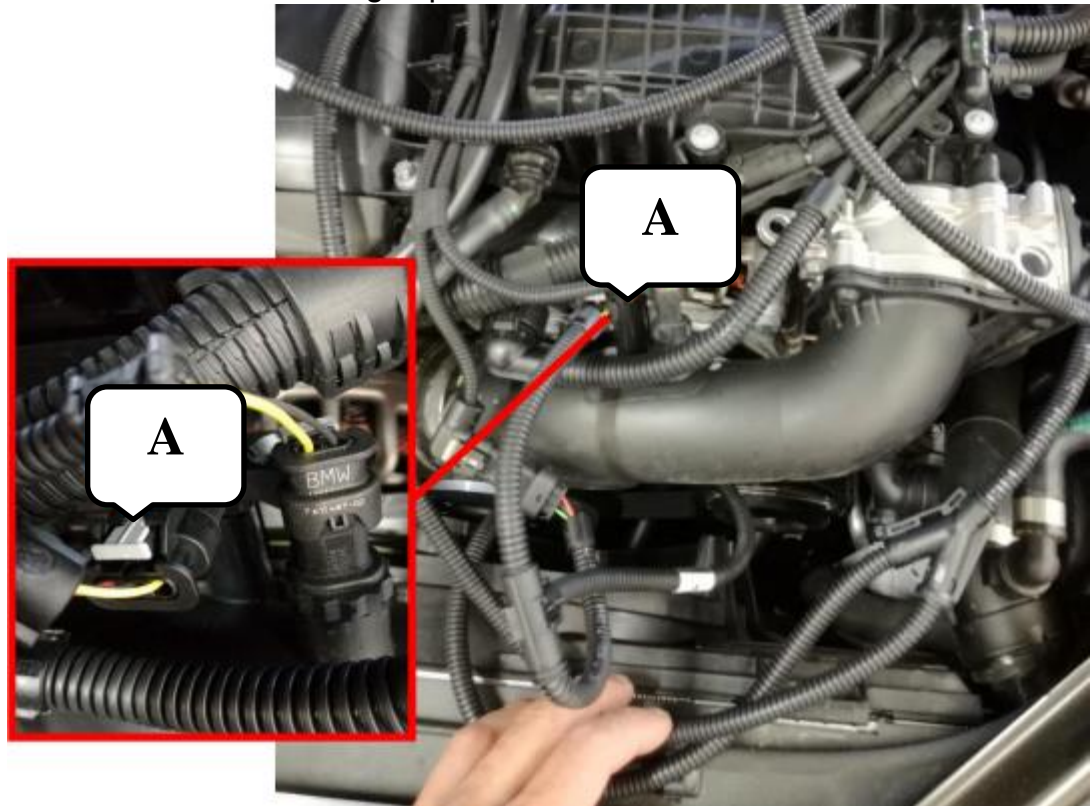

7.2 Location of Sensor B: Manifold Pressure Sensor

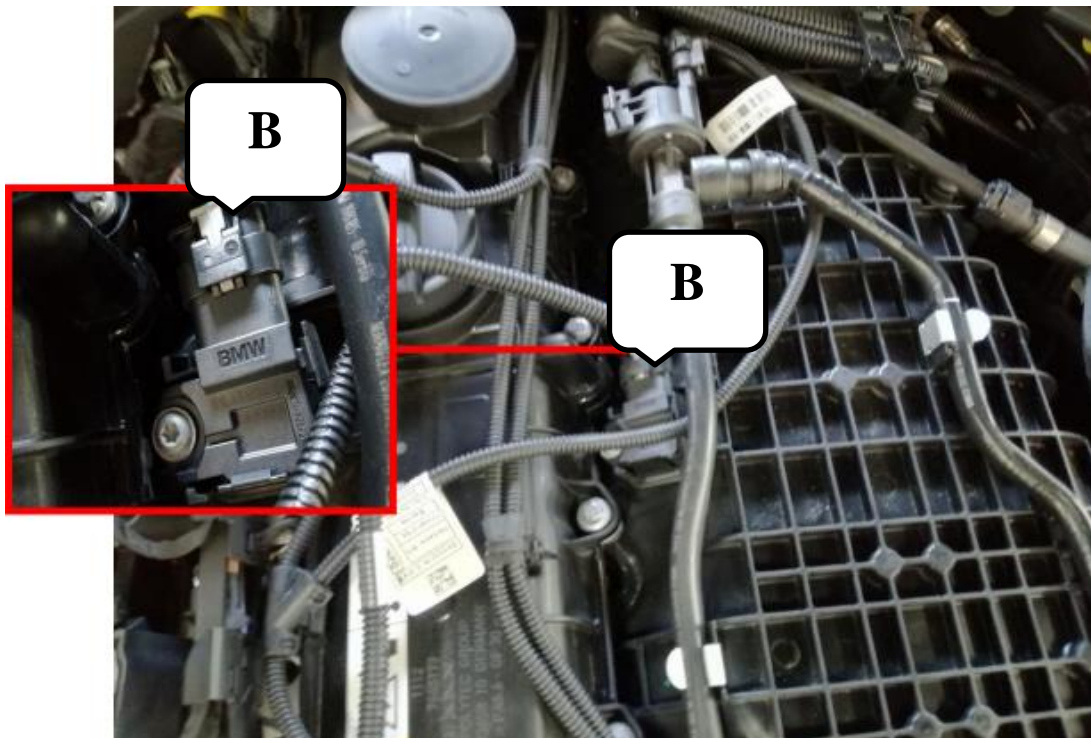

8. Determine a suitable location for the DINANTronics Elite ECU, away from any moving components, water, excessive heat and/or vibration.
 - Avoid all moving engine components or areas of extreme heat.
 - Ensure adequate slack in the wiring harness to allow for engine movement.
 - Use some of the included zip-ties to secure the harness as needed.
- 8.1 We recommend installing the DINANTronics Elite ECU in the passenger side compartment just in front of the windshield.
- 8.2 To remove this cover, simply turn the locks 90° counterclockwise, unlock the catch and pull the cover upward and outward.
- 8.3 The highlighted figure shows the DINANTronics Elite already installed in the space beneath the cover. Simply use the included Velcro strips to secure it into place.

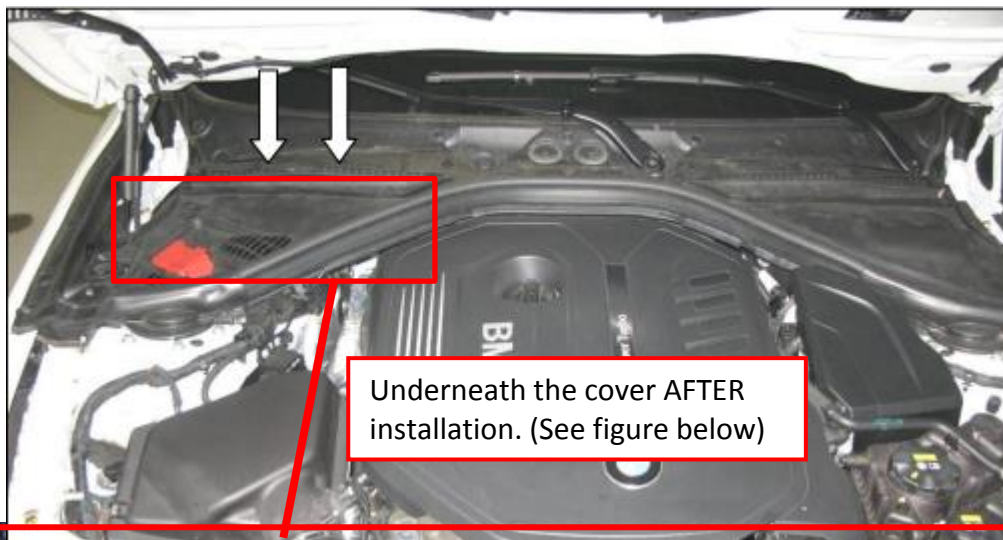

9. If you choose to mount the DINANTronics Elite ECU elsewhere:
- The DINANTronics Elite ECU will be attached to the included mounting plate using double-sided Velcro tape.
 - The mounting plate is fastened to the vehicle using the included zip ties following the guidelines in Step 7. The zip-ties may be routed thru the loops along the edges, and/or thru any of the square holes.

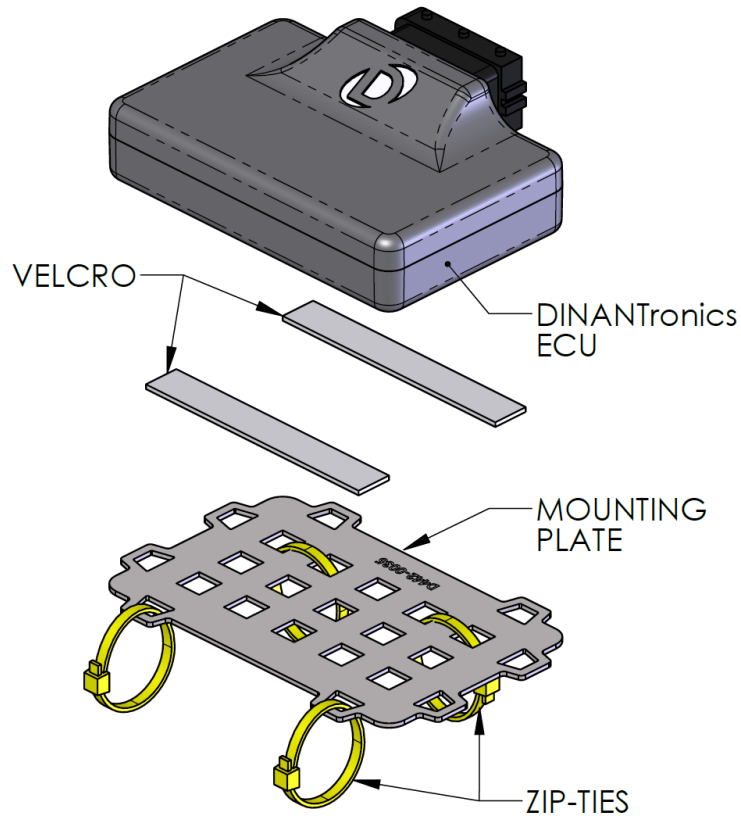

10. The DINANTronics Elite wiring harness is shipped with a bypass plug installed. This plug allows you to return the car to stock tuning, without removing the DINANTronics Elite harness from the vehicle.
11. Slide the purple latch outwards to release the bypass plug. Set aside the bypass plug for future use.
- Should stock tuning be desired, follow the steps in the "Prepare Vehicle for Installation" section; disconnect the DINANTronics Elite ECU; and attach bypass plug to the DINANTronics Elite harness.
12. Attach the DINANTronics Elite ECU to the harness and re-engage the purple latch to secure the connection.
13. Reinstall all removed engine compartment components.
14. Reconnect negative terminal of battery.
15. DINANTronics Elite installation is now complete. Happy motoring!