



INTERCOOLER UPGRADE INSTALLATION INSTRUCTIONS

PART NUMBER D330-0021

APPLICATION:	2014-16	F22 228i & xDrive coupe
(see restrictions below)	2012-16	F30 328i & xDrive sedan
	2014-16	F31 328i xDrive wagon
	2014-16	F32 428i & xDrive coupe
	2015-16	F36 428i & xDrive Gran Coupe
	2014-16	F22 M235i & xDrive coupe
	2012-15	F30 335i & xDrive sedan
	2014-16	F32 435i & xDrive coupe
	2015-16	F36 435i & xDrive Gran Coupe

Congratulations for being selective enough to use a Dinan Intercooler Upgrade Kit. We have spent many hours developing this kit to assure that you will receive maximum performance and durability with minimum difficulty in installation. Please take the time to read these instructions and call us if you have any difficulties during the installation.

Familiarity with BMW recommended procedures is required to install this kit. These documents are available at <http://www.bmwtechinfo.com/>

DO NOT WORK ON VEHICLES SUPPORTED BY A JACK ONLY. USE SECURE JACK STANDS!

NOTES:

This kit is not for use with the following vehicles:

- Any vehicle equipped with Active Cruise Control.
- Any F23 or F33 convertible, regardless of bumper
- Any F22 with standard bumpers

Do not attempt installation if you have one of these excluded vehicles. New applications are continually being released. Contact your Dinan representative for further details.

*** Note for F30 or F31 with M-Tech bumpers:** To improve appearance of the center grille after intercooler installation, Dinan recommends the purchase of an optional hardware kit, #D333-0025. Please contact your sales representative for details.

PARTS LIST

Qty	Part #	Description
1	D333-0024	Intercooler Assembly
1	D332-0040	Diffuser; Undercar
1	D333-0021	Hardware Kit

REMOVE THE STOCK INTERCOOLER:

1. Remove the front bumper per BMW recommended procedure.
2. Remove the bumper beam:
 - Remove the two plastic clips at the bottom of the upper radiator duct.
 - Remove the 4 bolts that secure the bumper beam. Tilt the bolts as needed to clear the headlight. Removal of the headlight is not required to extract these bolts.
 - Remove bumper beam & set aside.
3. For non-M235i applications only: Remove the lower shroud support and set it aside. This is not be reused on some models.

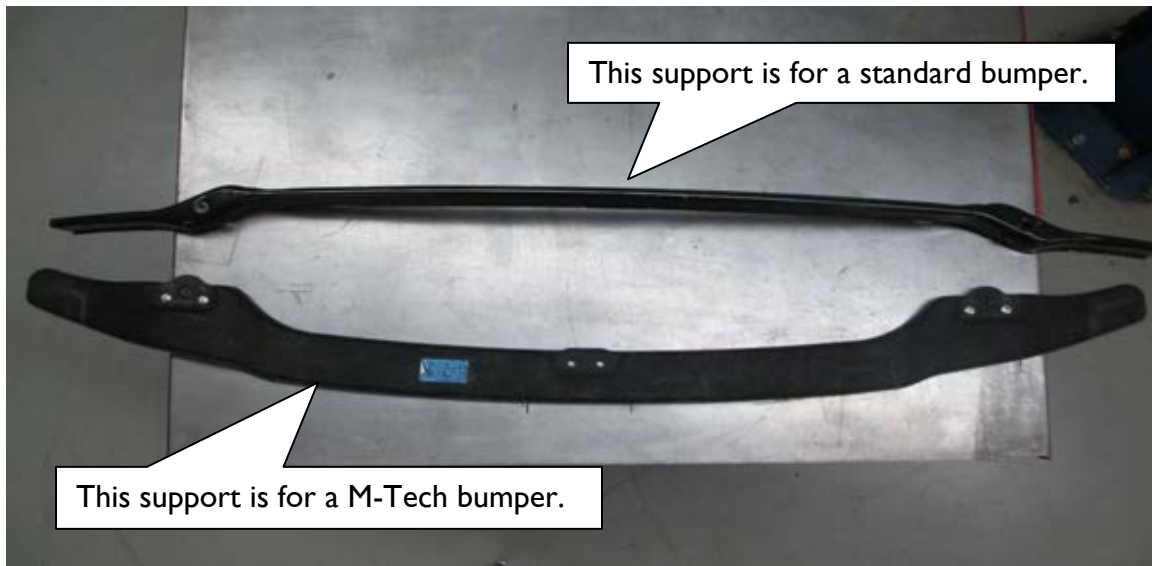

4. Remove the lower air duct from in front of the intercooler.

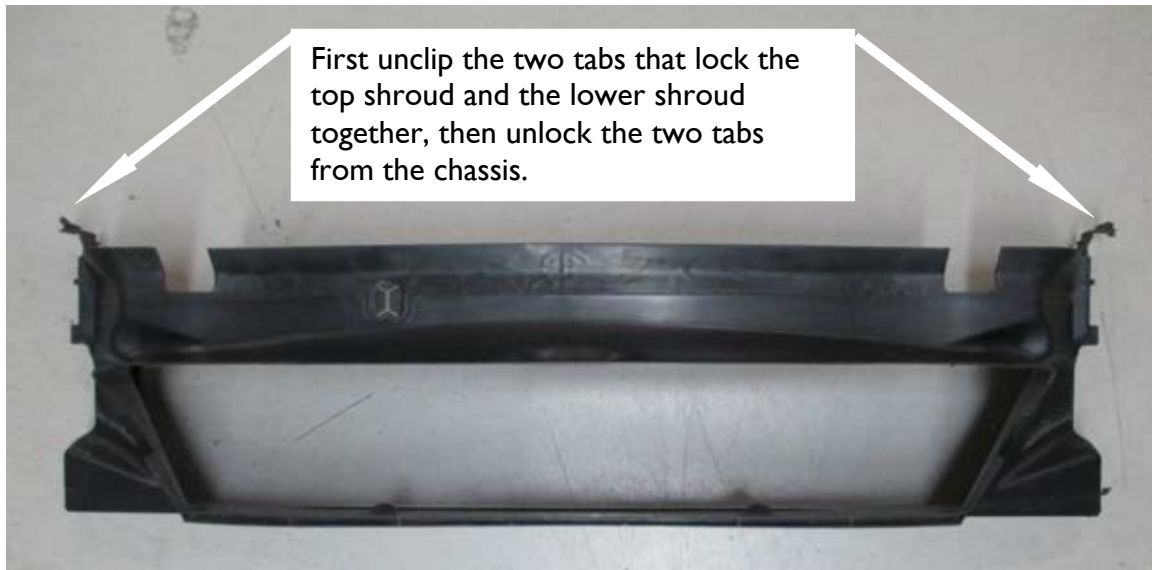

5. Disconnect the charge air pipes from the intercooler:
 - Push the hoses toward the front of the car, then release the clips (see photo below).
 - Remove both of the charge tubes from the intercooler.

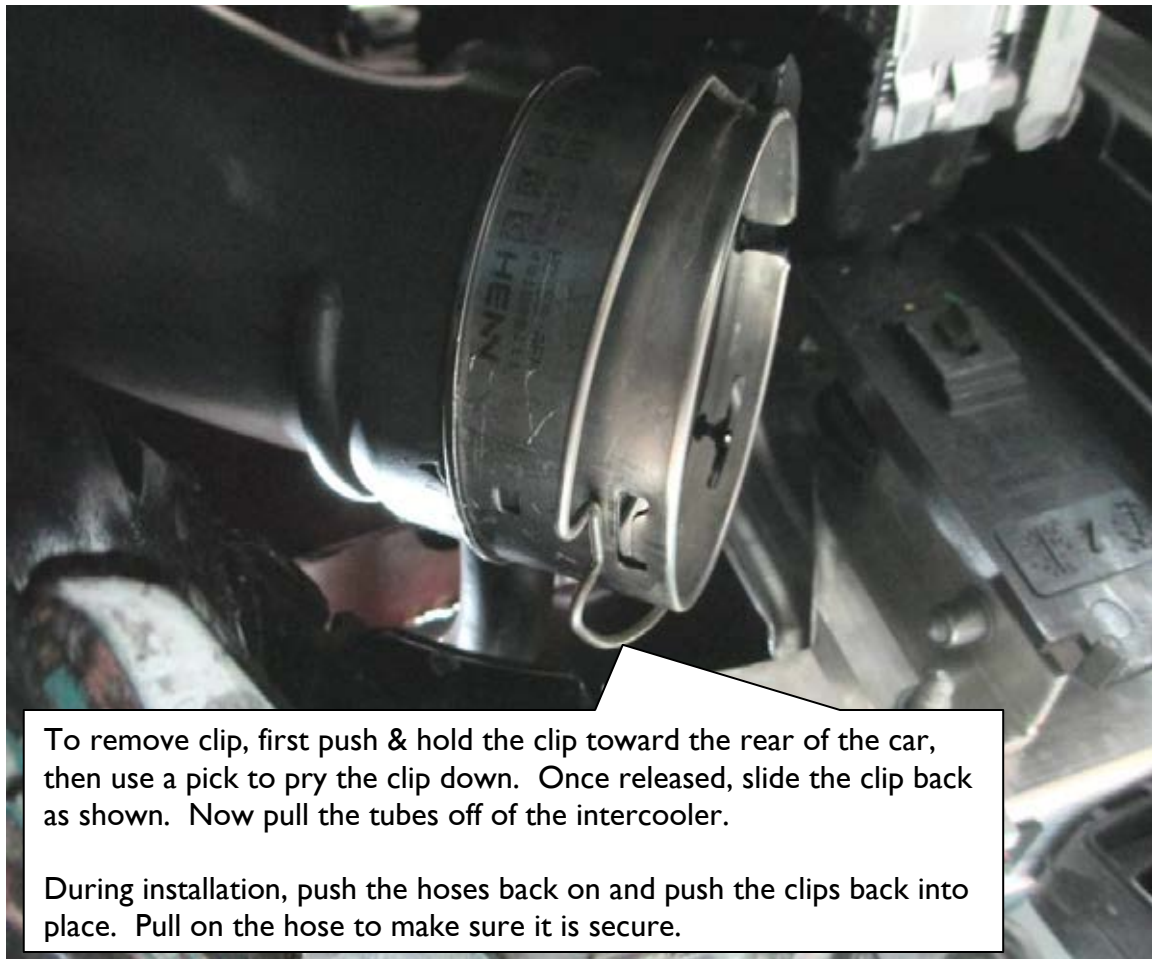

6. With the hoses disconnected, remove the two bolts from the stock intercooler and remove unit from the car.

INSTALL DINAN INTERCOOLER:

7. On the bumper beam, locate the two holes that held the upper radiator duct. Drill out these holes to 17/32".



8. Install a rivet nut into each hole using the included installation tool. Refer to instructions included with the tool for proper use. Spare rivet nuts are provided for your use if necessary.



9. Reinstall the bumper beam.

10. For F30 / F31 / F32 with standard bumper only:

Install the foam from the kit to the underside of the front intercooler and up both side tanks as shown below.

- Make sure the surface is clean before you apply the foam.
- Start from one end and work your way around.

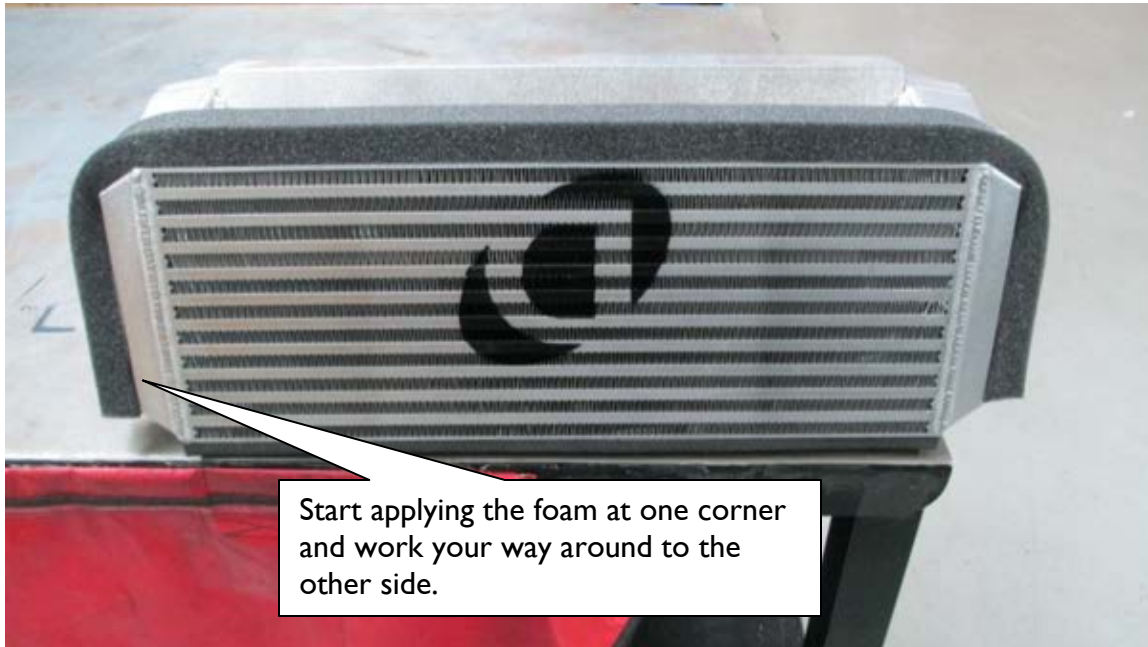

11. For F22 / F30 / F31 with M-Tech bumper only:

Install the foam from the kit only to the underside of the front intercooler as shown below

- Make sure the surface is clean before you apply the foam.
- Cut off the excess foam after installation.



12. See photos below.

- Insert the two rubber mounts and metal sleeves into the tops mounts of the Dinan intercooler.
- Locate the two rubber flaps included in the kit and lay them out in front of the Dinan intercooler.
- Clean the flaps using the included alcohol wipes and apply the strips of double-sided tape at the indicated locations.

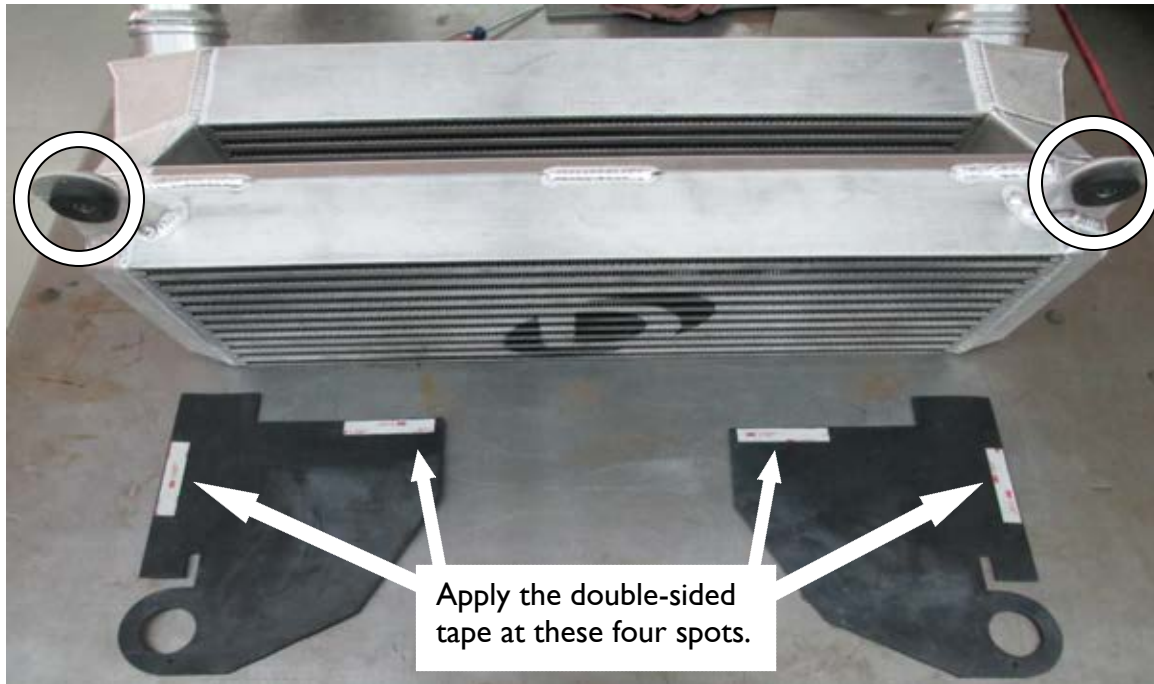

13. Turn the flaps over and hold up to intercooler as shown. Do not use the tape yet.

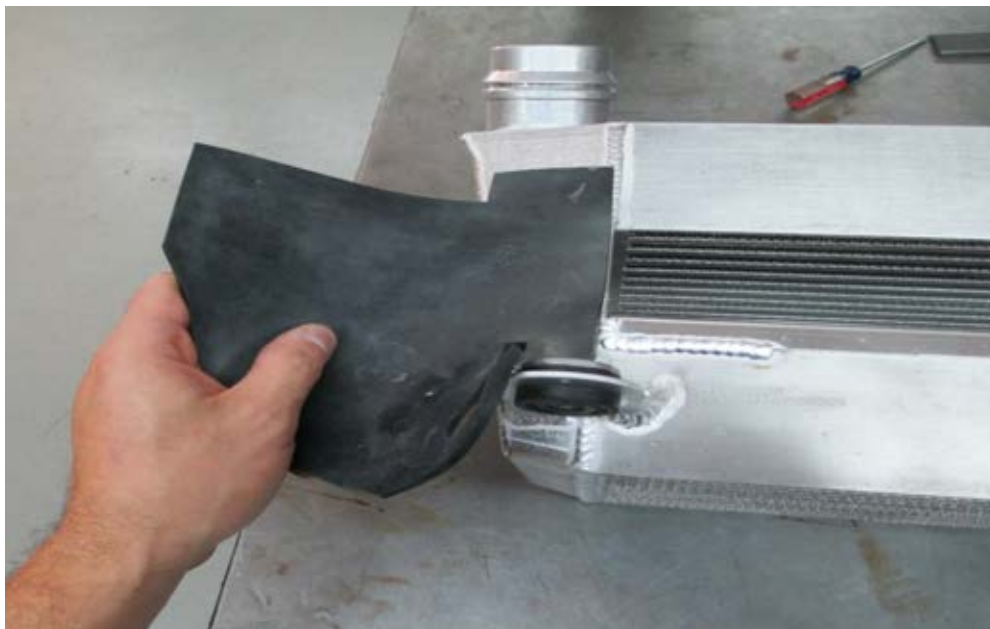

14. Fold hole in flap around rubber mounts as shown and secure into place with the rivets included in the kit.



15. Remove liner from one of the tape sections and secure flap to intercooler as shown. Repeat for other side.



16. In preparation for intercooler installation, use a piece of tape to hold down the flap on both sides as shown.

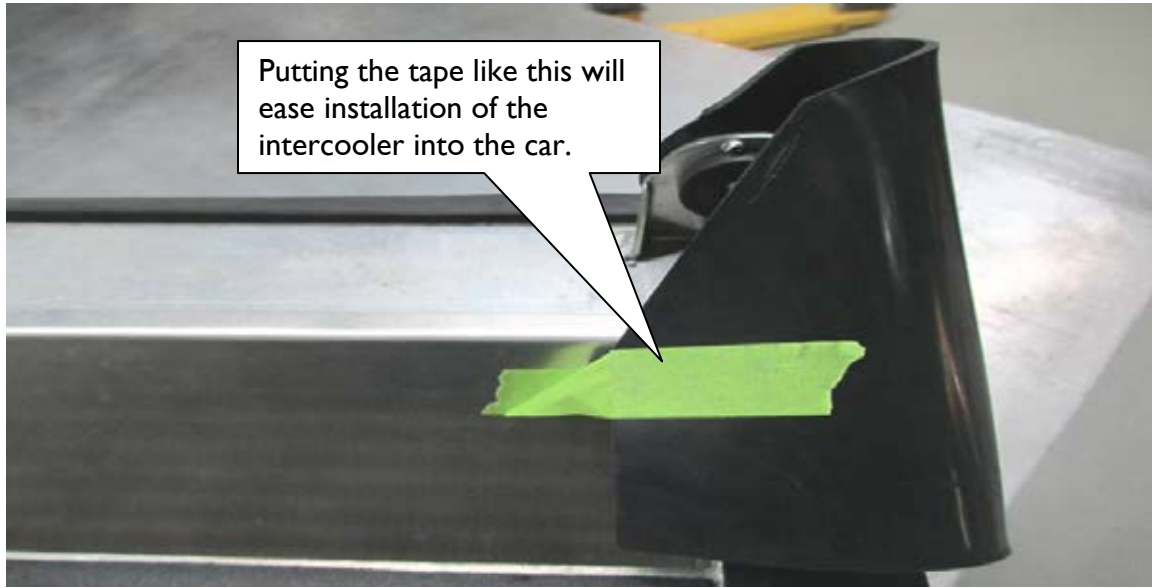

17. Bolt intercooler into place:

- Hold intercooler into place and loosely attach the two lower mounting bolts.
- Remove the tape from the flaps.
- Install the two M8x35 bolts and 8mm wave washers into the bumper beam, making sure to run the bolts thru the rubber straps on the upper duct in the upper hole. Tighten the two M8 bolts.

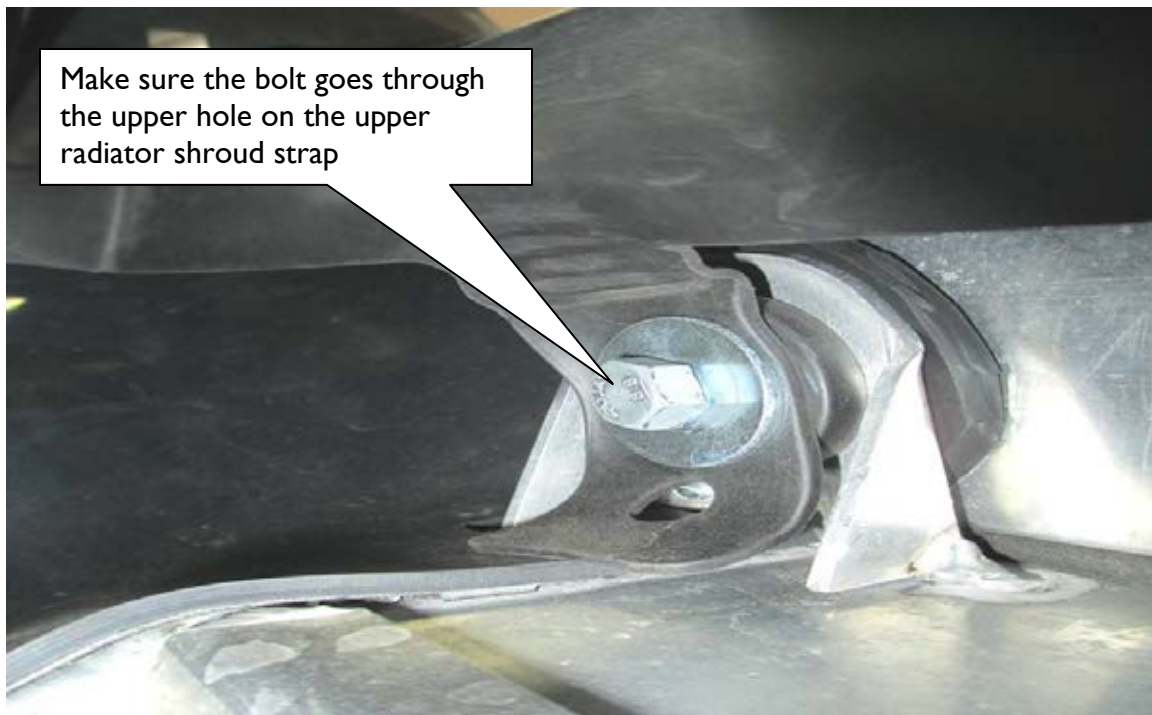

18. Install the rubber flaps:

- Place the rubber flaps as shown in the photo below.
- Make sure the flap tab is under the radiator as shown.
- Tighten the lower intercooler bolts.
- Align flap with the edges of the core support and apply adhesive to core support.



19. Verify that the two bent tangs at the lower rear edge of the intercooler has latched the two tabs of the radiator shroud as shown below.



20. If your vehicle is a F32 or F36 with the standard bumper as shown below, please follow Steps 21 thru 23 for bumper modification.



21. Measure 1-1/8" down from top edge, on all three sides, making a mark every couple of inches. Connect your dots, and trim the bumper along the line as shown in the photo.

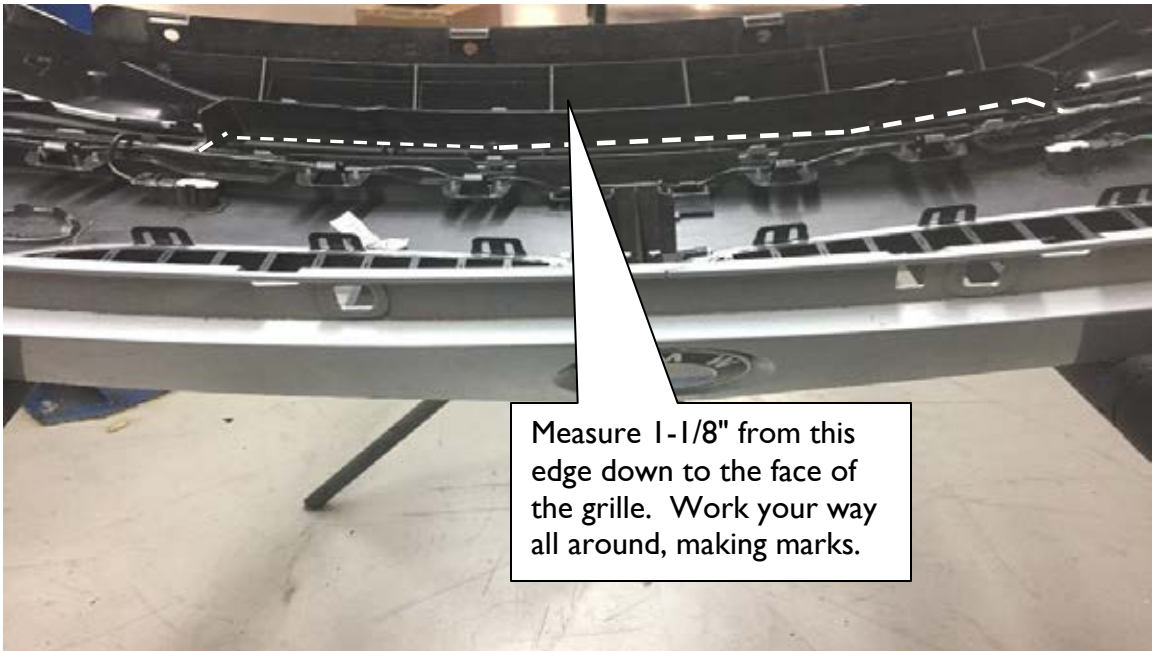

22. Then trim off the 5 small tabs and clean up the edges.



23. Reinstall bumper and skip to Lower Cover Modification (Step 52).

24. If your vehicle is a F32 or F36 with a M-Tech bumper as shown below, simply reinstall the bumper and skip to Lower Cover Modification (Step 52). No trimming is necessary for this application.



25. If your vehicle is a F30 or F31 with the standard bumper as shown below, please follow Steps 26 thru 27 for bumper modification.



26. With the bumper on a body stand, trim along the line as shown in the photo below.

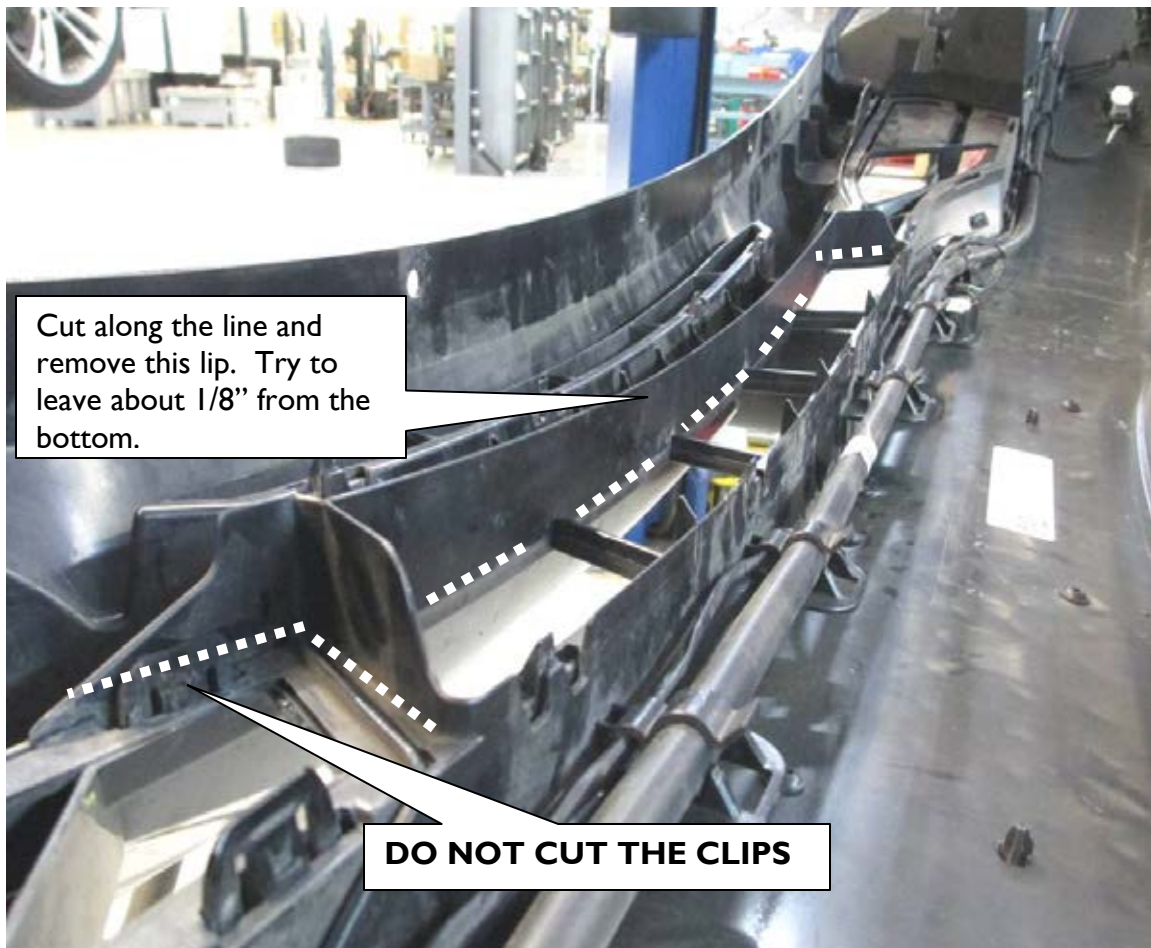

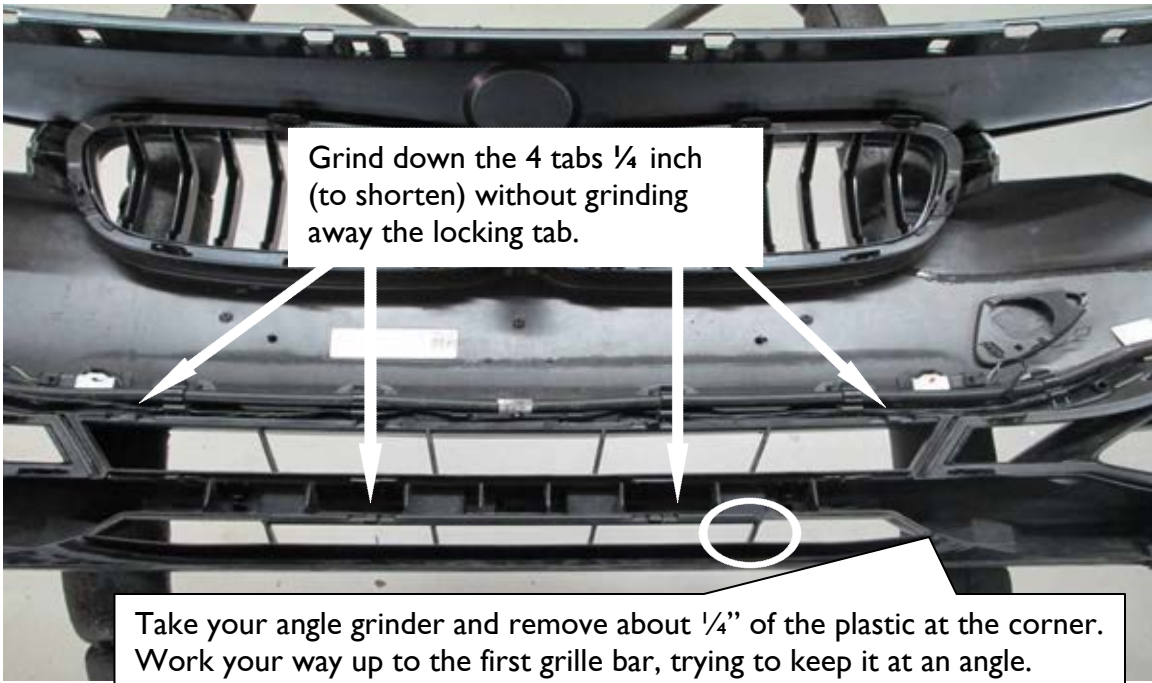

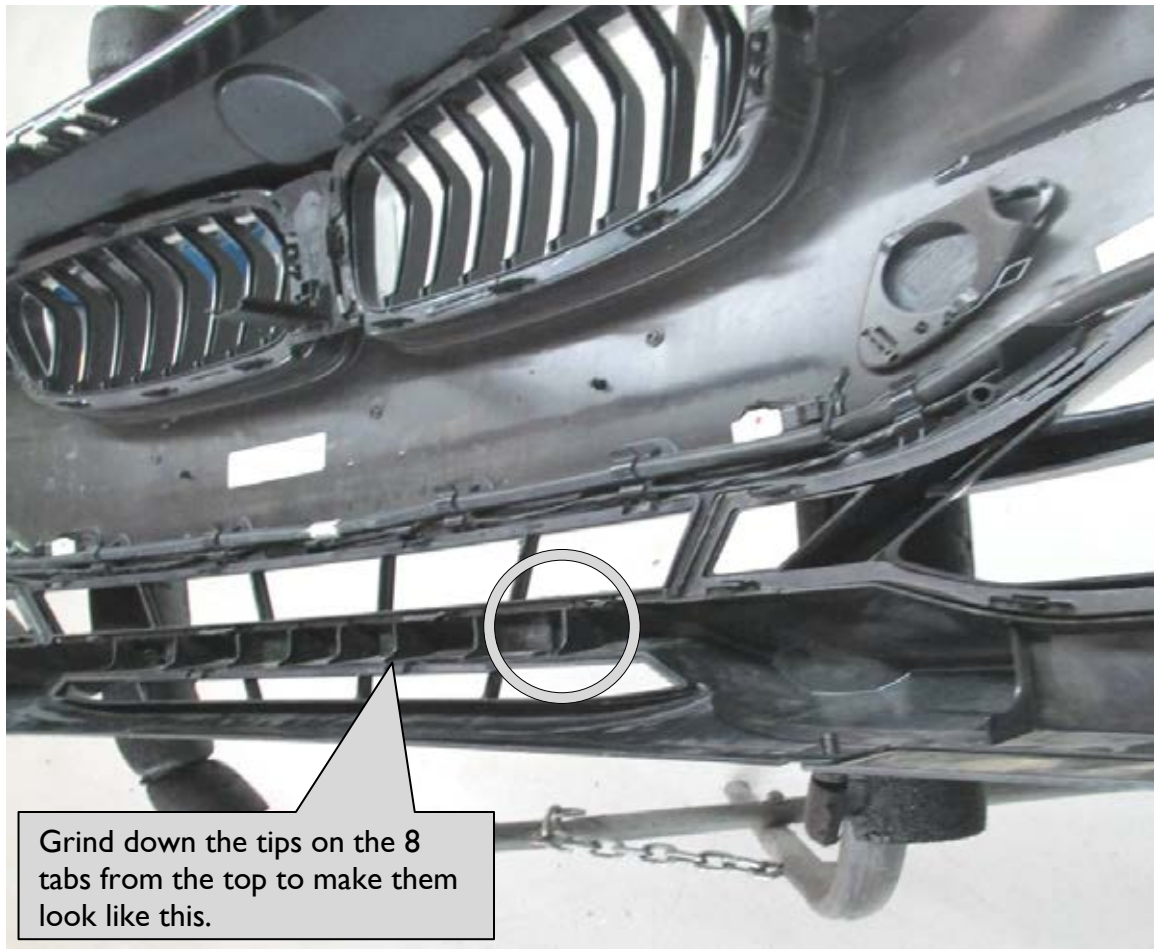

27. Reinstall the bumper, and skip to Lower Cover Modification (Step 52).

28. If your vehicle is a F30 or F31 with the M-Tech bumper as shown below, please follow Steps 29 thru 39 to trim the grille and the brake ducts.



29. Refer to steps 41 & 42, and remove the brake ducts from the vehicle.



30. The templates below will be used to mark the trim areas on both brake ducts. Flip template over when using them for the other side.

- Verify the measurements of the templates below.
- If necessary, scale & reprint this page to obtain accurately sized templates.
- Cut out the templates.

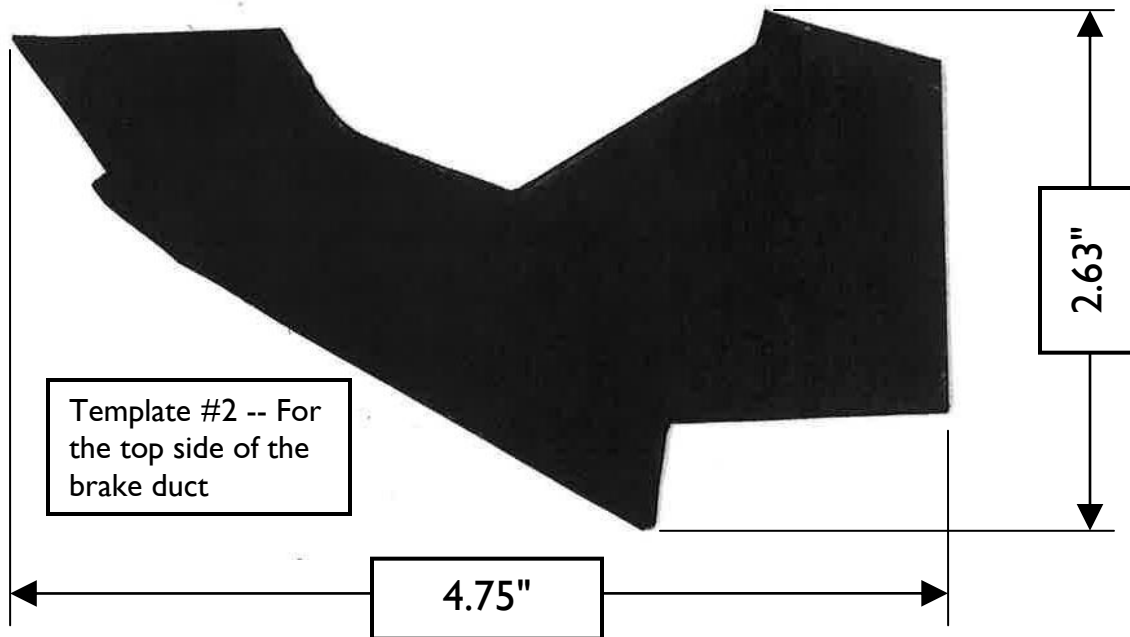
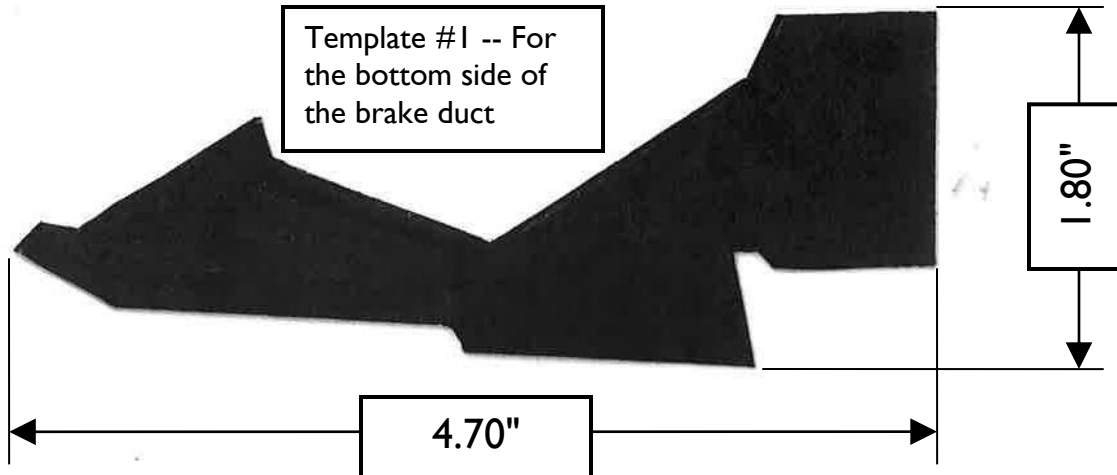

31. Take template #2:

- Place it onto the top side of the brake duct.
- Line up the edges shown in the photo below.
- Once the template is aligned, make marks as shown.
- Flip the template over and repeat for the other brake duct.



32. Take template #1:

- Place it onto the bottom side of the brake duct.
- Line up the edges shown in the photo below.
- Once the template is aligned, make marks as shown.
- Flip the template over and repeat for the other brake duct.

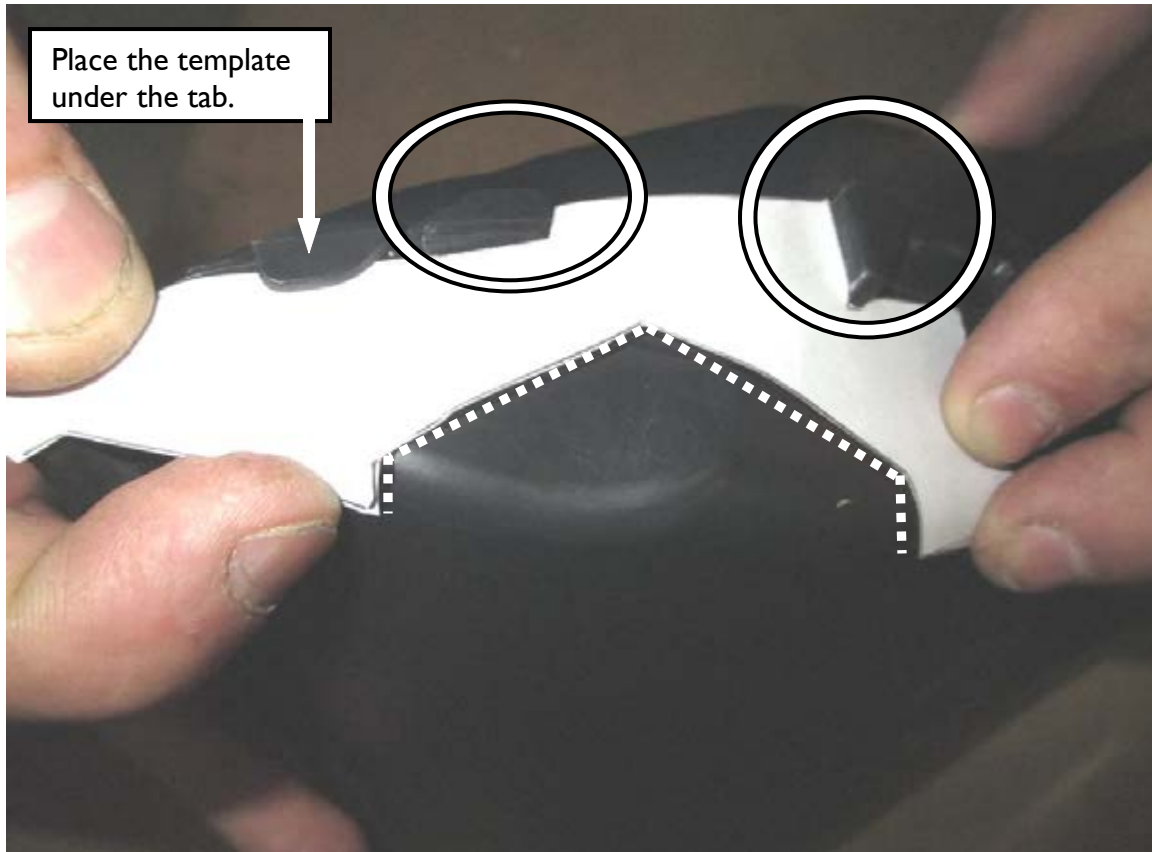

33. Take a straight edge and connect the dots.



34. Double check your marks with the templates. Once confirmed, make your cuts.



35. After cutting, reinstall the brake ducts and cooler shrouds. Place the bumper back on the car but only install the single bolt on either side of the bumper (see photo below) to temporarily hold the bumper into place.



36. To direct more cool air to the intercoolers, the brake ducts have been moved outward, resulting in a small gap with the front grille. Dinan's optional D333-0025 hardware kit includes components to close these gaps and improve the appearance of this installation.

37. With the bumper held in place:

- Take the Dinan grille covers and hold them into place as shown below.
- Mark the two holes.
- Repeat on other side.
- Remove the bumper and drill 1/4" holes at the four marked locations.

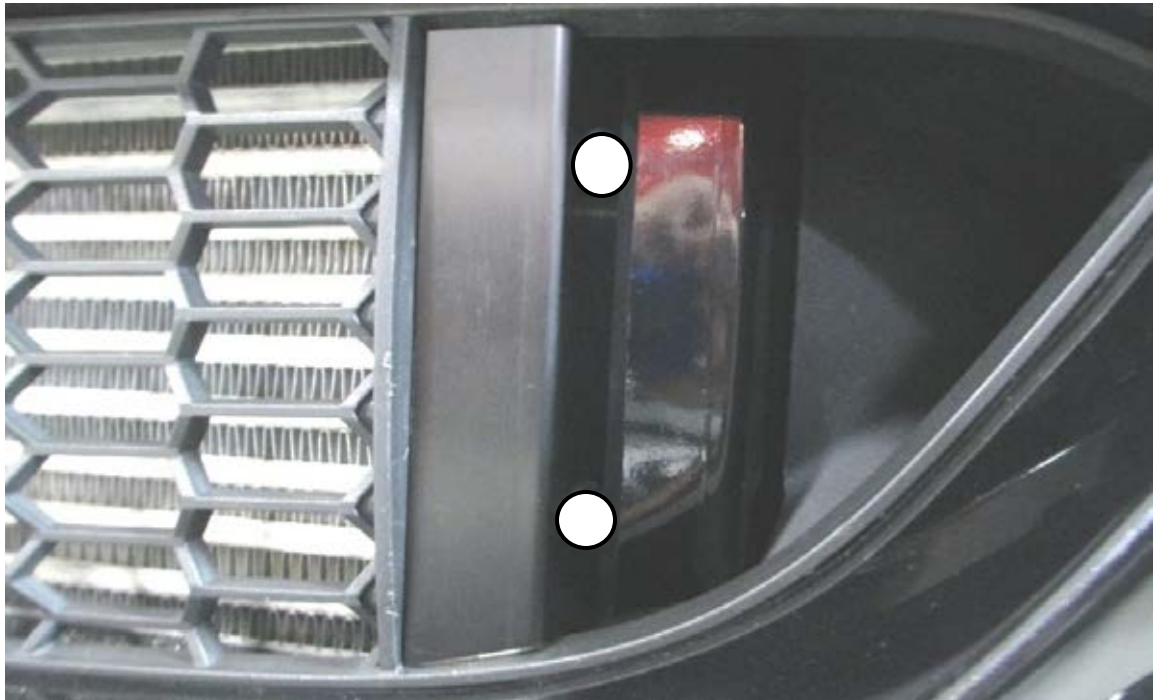

38. Reinstall the bumper.

- Place the grille covers into position.
- Fasten with the included push pins.

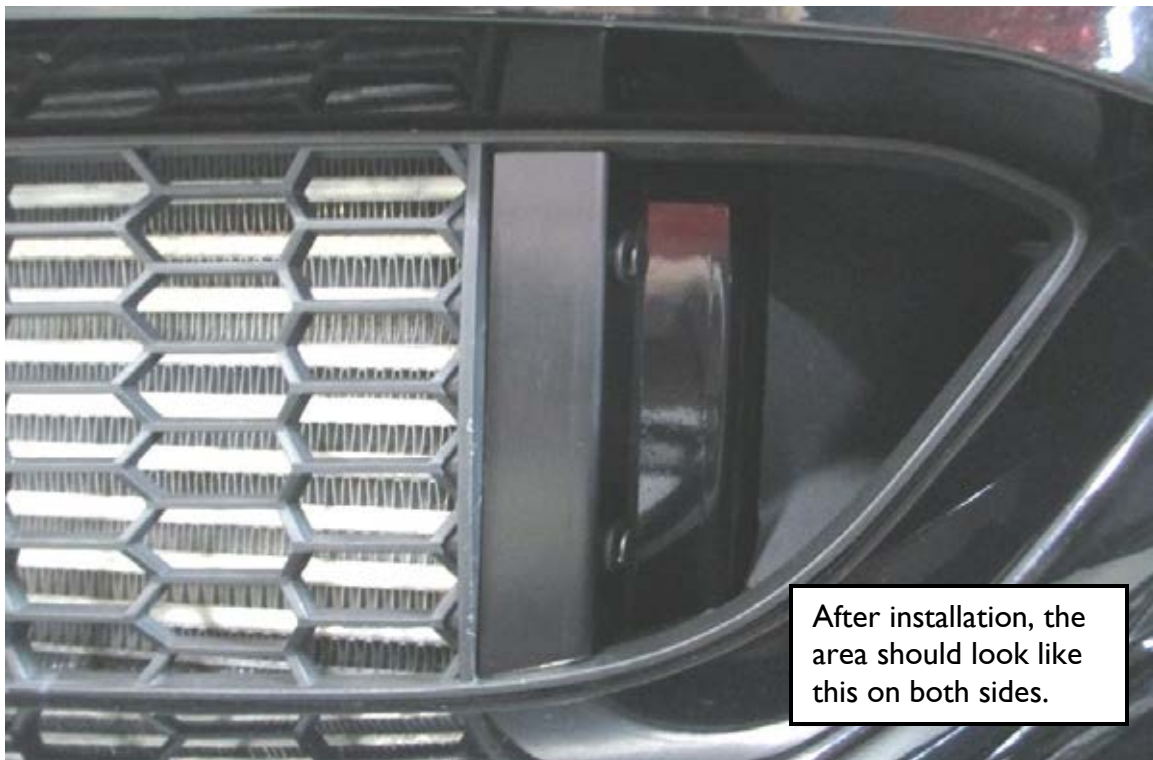

39. Skip to Lower Cover Modification (Step 52).

40. If your vehicle is a F22 with the M-Tech bumper as shown below, please follow Steps 41 thru 51 to trim the grille and the brake ducts.



41. Remove the ducts from both the right side (oil cooler) and the left side (duct radiator).



42. Remove the brake ducts from both sides of the car.

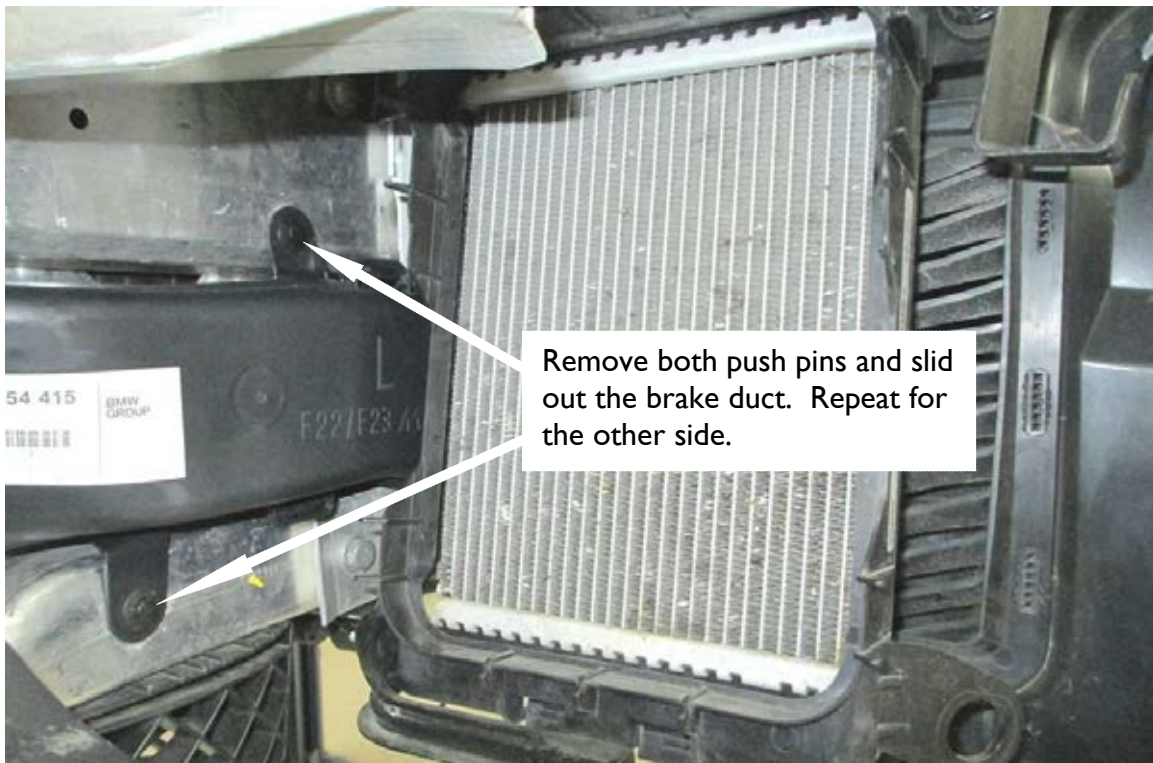

43. The template below will be used to mark the trim areas on both brake ducts. Flip template over when using it for the other side.

- Verify the measurements of the template below.
- If necessary, scale & reprint this page to obtain an accurately sized template.
- Cut out the template.



44. Place the template on the duct as shown below.

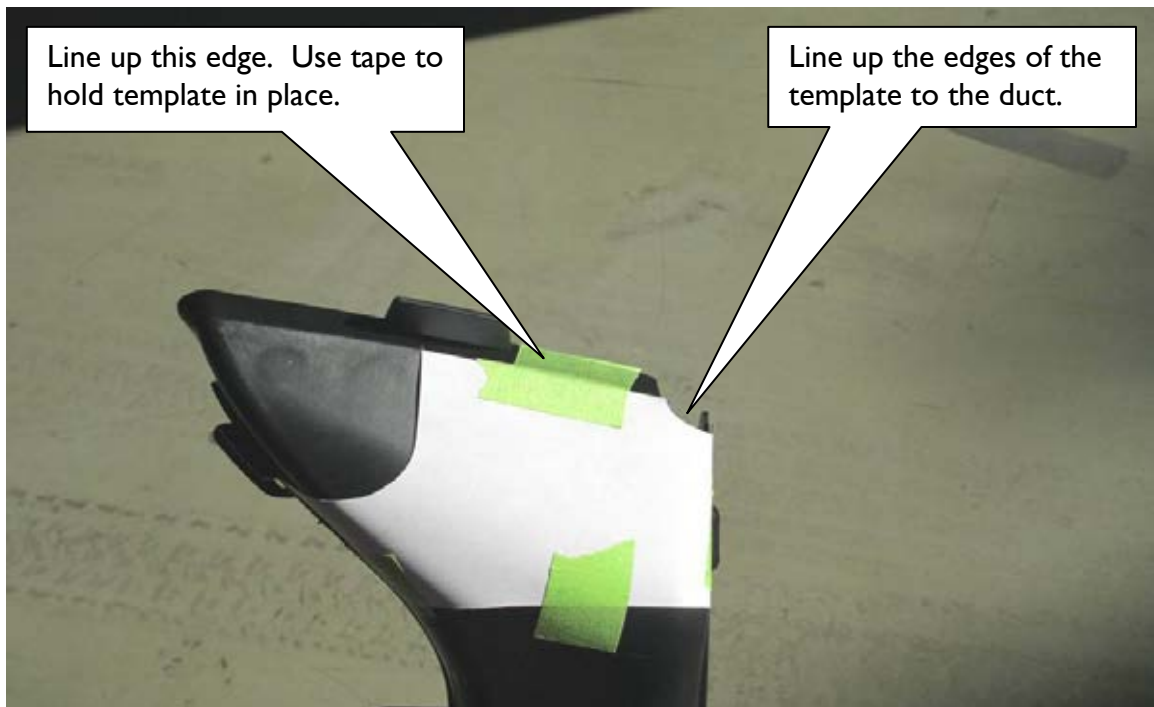

45. Mark the lines as shown in the photos, remove template, and trim the brake duct. Repeat for other side.

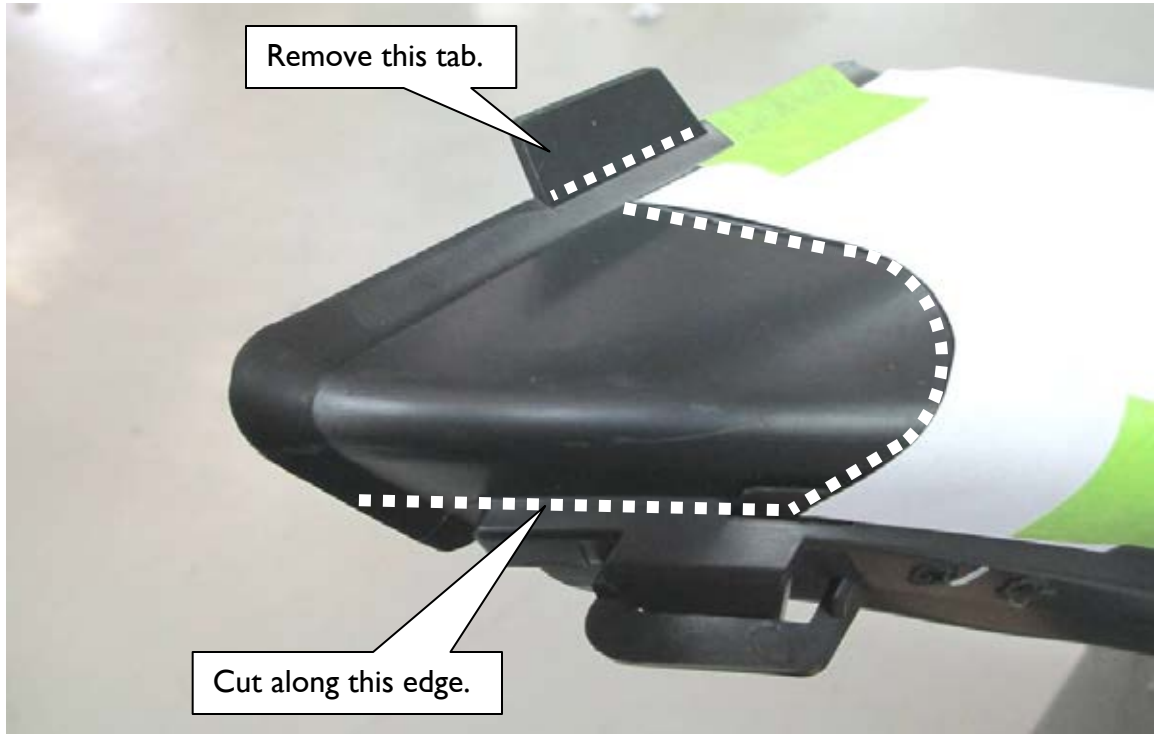

46. Remove this section of the duct indicated in the photos below.

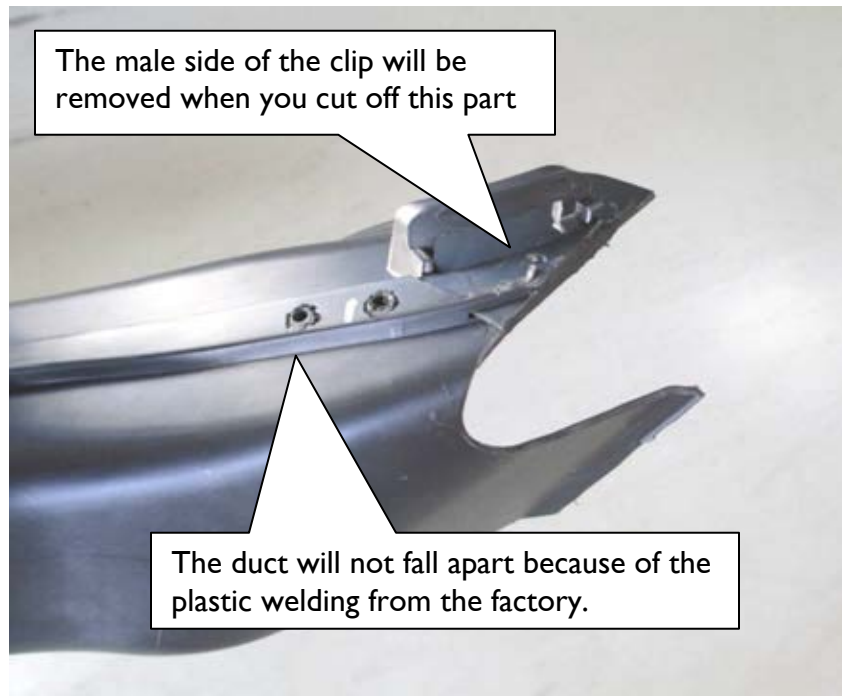
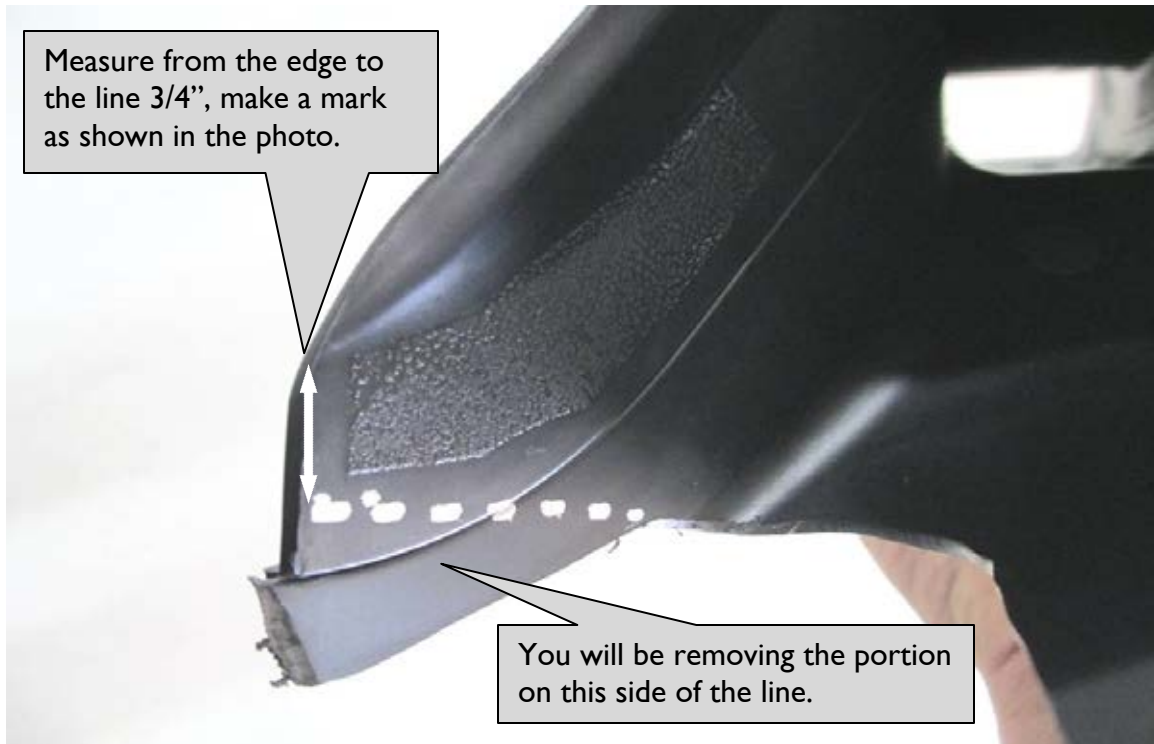

47. Reinstall both brake ducts and cooler ducts into the car.



48. Mark & trim the ducts in the grille as shown. You will be cutting on the dotted lines.

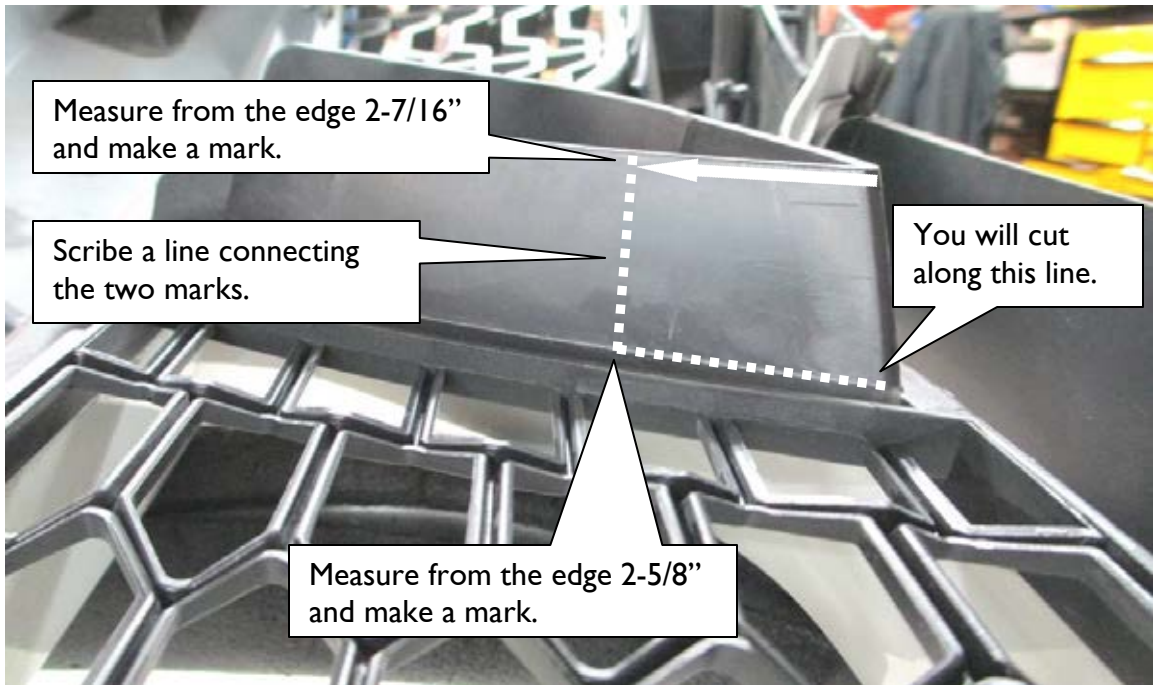

49. Mark the bottom as shown in the photo.

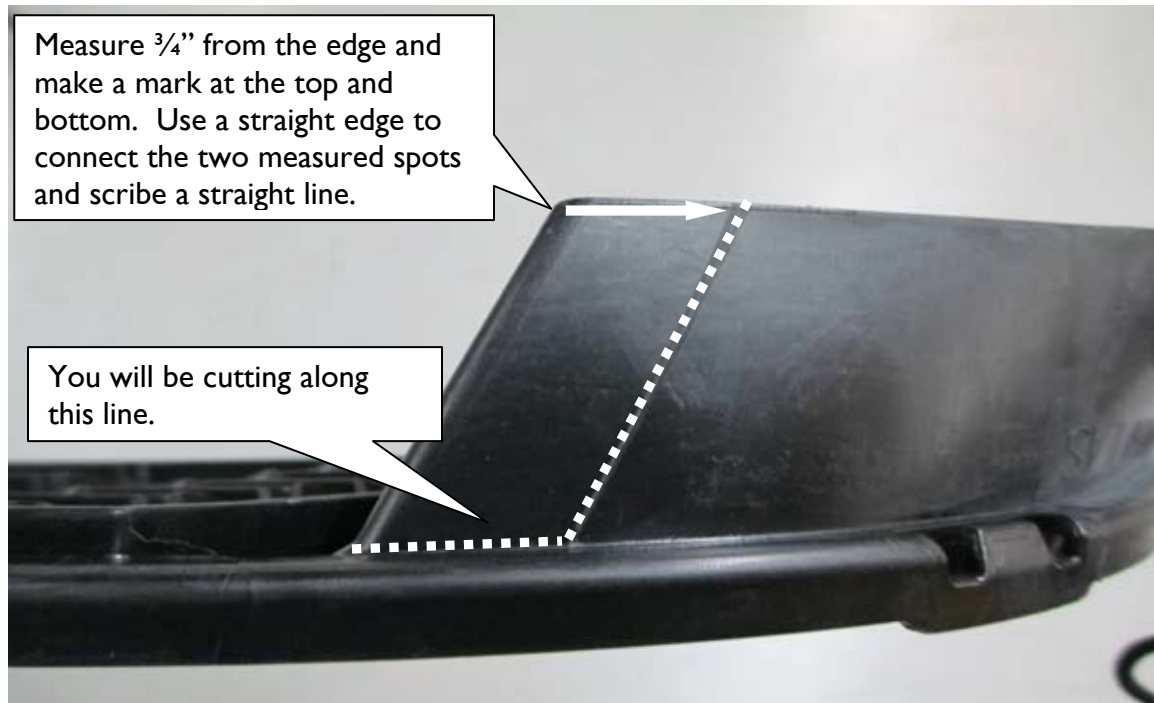

50. Make cuts at your marks and remove pieces from the grille. The photo shows the completed modifications. Repeat on the other side.



51. Reinstall the bumper, and continue with Lower Cover Modification.

LOWER COVER MODIFICATION (for all cars):

52. Lay the lower cover on the flat surface with the bottom side up as shown. An opening will need to be cut to all airflow thru the front intercooler core to exit underneath the car. Measurements will be taken from the centers of the two attachment clips indicated below.



53. Make the measurements shown below and mark out the 3" x 21-1/2" rectangle which will be the exit for the front core.

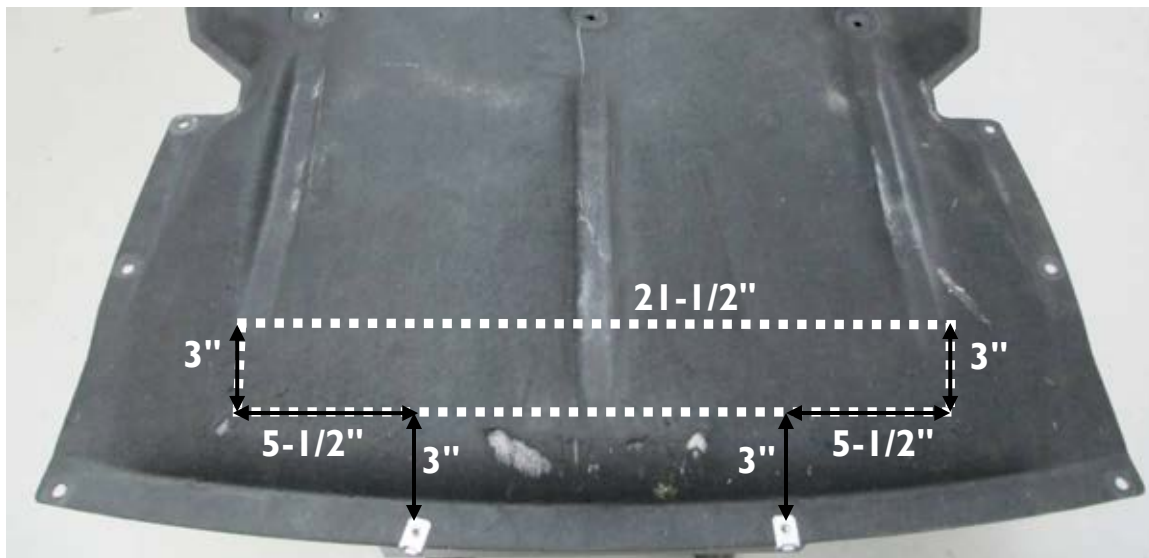

54. Double check your measurements and cut out the rectangle.

55. Install diffuser to lower cover:

- Line up diffuser with front of opening as shown below. The panel with the holes rests against the lower cover.
- Mark the locations of the 4 holes onto the lower cover.
- Drill all four holes to 1/4".
- Install diffuser using the supplied 5mm hardware and fender washers.



56. Reinstall lower cover to vehicle. The back of the your opening in the lower cover must fit securely into the slot of the intercooler as shown below.



57. For best performance, please also install the appropriate DINANTronics ECU with Stage 3 software.

58. Using a scan tool or equivalent, clear fault memory after installation is complete.

59. Happy Motoring!