

Detroit Speed
Selecta-Speed™ Wiper Kit
 1962-64 Chevy II, 1965 Chevy II "100 Series" & "SS" and "400 Series" Trim,
 1966 Chevy II & 1967 Chevy II
 P/N: 121614, 121616, 121617 & 121618

The Detroit Speed Selecta-Speed™ Wiper Kit provides you with the performance and convenience of a late model wiper system in a package that easily and cleanly mounts in your 1962-1967 Chevy II.



Item	Description	Quantity
1	Wiper Motor & Module Assembly w/ Adapter Plate	1
2	Wiper Harness	1
3	Wiper Switch Assembly	1
4	Wiper Knob w/ Set Screw	1
5	Wiper Switch Bezel	1
6	Firewall Cover Plate w/ Seal	1
8	10-24 x 3/4" L Stainless Steel Screws	3
9	10-24 Stainless Steel Nylock	3
10	10-24 x 1/2" OD Washer	3
11	Instructions	1

Important: *The Detroit Speed Selecta-Speed Chevy II Wiper Kit is NOT compatible with the factory GM HVAC system. Please contact Detroit Speed if you need assistance with selecting an alternative HVAC system.*

Important: *If you are using the Vintage Air Gen IV Magnum Evaporator, you will need to modify the outlet vents on the Evaporator. For the wiper linkage to clear the Evaporator, the top 2 outlets will need to be trimmed or removed and then closed out (Figure 1).*



Figure 1 – Gen IV Magnum Modification

This kit features a seven-speed wiper system with five delays, low speed, and high speed. A CNC aluminum adapter plate and custom mounting bracket, mount the wiper motor to the stock firewall bolt pattern. The new pitman arm, included in the kit, connects directly to your existing wiper linkage. A rotary switch with a billet aluminum knob is also included, along with the complete wiring harness.

This kit does feature a washer pump option as the wiper switch does have a push button function. The wiring harness/control module is equipped with a power and ground wire to install an inline electric washer pump. Detroit Speed does offer a washer pump kit available as part number 121102.

Before beginning your installation, confirm that the included interior knob and bezel match the factory knob and bezel for your year car. Figure 17 at the end of the directions shows the correct knob for each car.

Installation Instructions:

1. Before beginning, please ensure that the parts included with your kit match the parts list above. Ensure that the factory wiper system is in its “Parked” position. Disconnect the battery power by removing the negative battery lead from the battery. Mark the position of the wiper arms by placing masking tape on the windshield. This will assure the arms are accurately replaced.
2. Disconnect the wiper linkage from the wiper motor pitman arm by removing the pitman arm clip (Figure 2). Slide the wiper linkage off the pitman arm and remove the stock wiper motor and wiper linkage from the firewall. **NOTE:** The pitman arm clip will be re-used. Take careful note of the wiper linkage configuration as it will be modified slightly and reinstalled later.



Figure 2 – Pitman Arm Clip

3. The original wiring will not be used with the new Selecta-Speed Wiper Kit. A custom harness is provided to replace the original. **NOTE: If you decide to cut the old wires please pay special attention to properly terminate the wire ends to avoid possible shorting.**
4. Mount the firewall cover plate with the attached seal to the firewall using the supplied 10-24 x 3/4" L stainless steel screws so that the screws protrude through the factory wiper motor weld nuts. **NOTE: The firewall cover plate is finished in an "E-coat" primer and can be painted if desired.**
5. The wiper motor assembly and the wiper control module is installed on the wiper motor mounting bracket for easy shipping. Remove the wiper motor mounting bracket from the wiper motor assembly by removing the four 10-24 x 1/2" L Allen screws from the adapter plate and slide the motor and adapter plate out of the stamped mounting bracket. Remove the wiper control module from the mounting bracket by removing the two 8-32 x 1/2" L screws from the mounting bracket.
6. Mount the wiper motor mounting bracket to the firewall by attaching it to the protruding cover plate screws from step 4 using the supplied washers and 10-24 Nylock nuts (Figure 3 & 4).

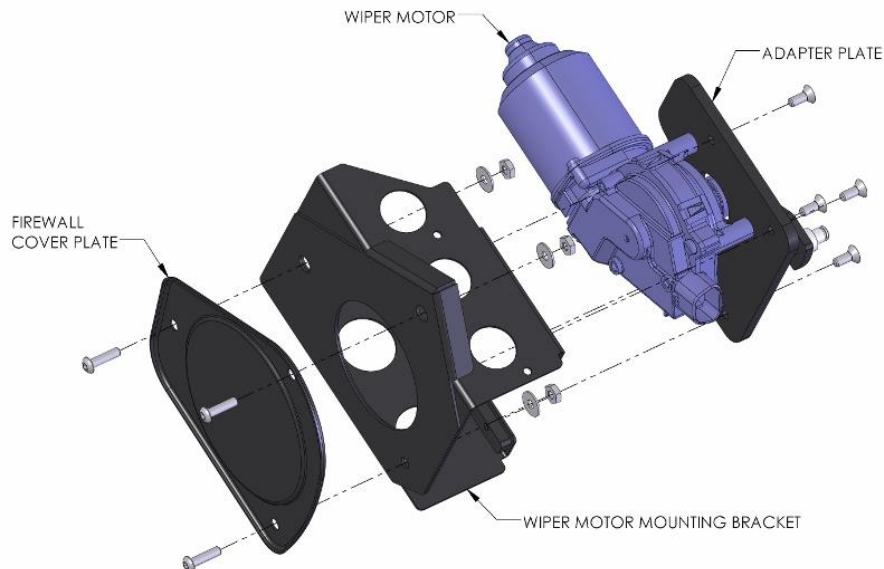

Figure 3 - Cover Plate, Mounting bracket, Wiper Motor, and Adapter Plate Assembly

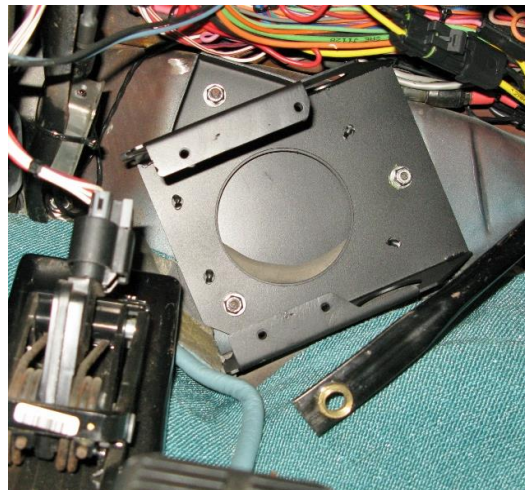

Figure 4 - Install Mounting Bracket

7. Install the wiper control module to the top side of the wiper motor mounting bracket using the provided 8-32 hardware that was removed in step 5 (Figure 5). There are two small bolt holes pre-drilled in the bracket to attach the control module. Do not overtighten. **NOTE:** Make sure the connectors are facing away from the firewall.



Figure 5 - Install Wiper Control Module

8. Attach the wiper motor and adapter plate to the stamped mounting bracket using the 10-24 x 1/2" L Allen screws you removed in step 5 (Figure 6). **NOTE:** The pitman arm should be in the 8 o'clock position.

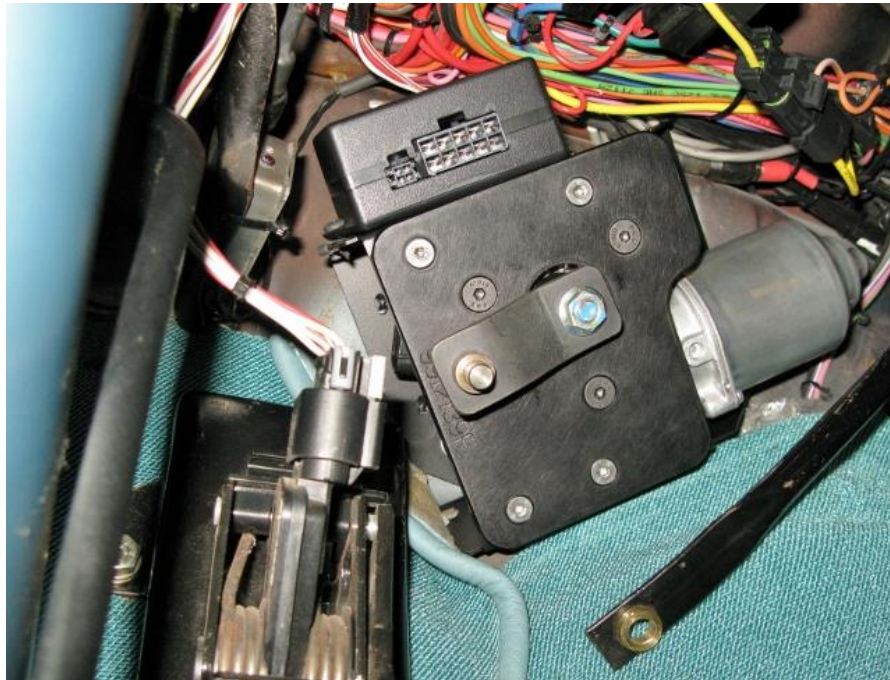

Figure 6 - Install Wiper Motor & Adapter Plate

- Using a bench vise, bend the factory wiper linkage slightly (about 10°) to accommodate for the difference in the new pitman arm position. An appropriately sized drill bit can be placed in the vise with the linkage end to help protect the bushings in the linkage and ensure proper bend location (Figure 7). The final linkage shape is shown in Figure 8.

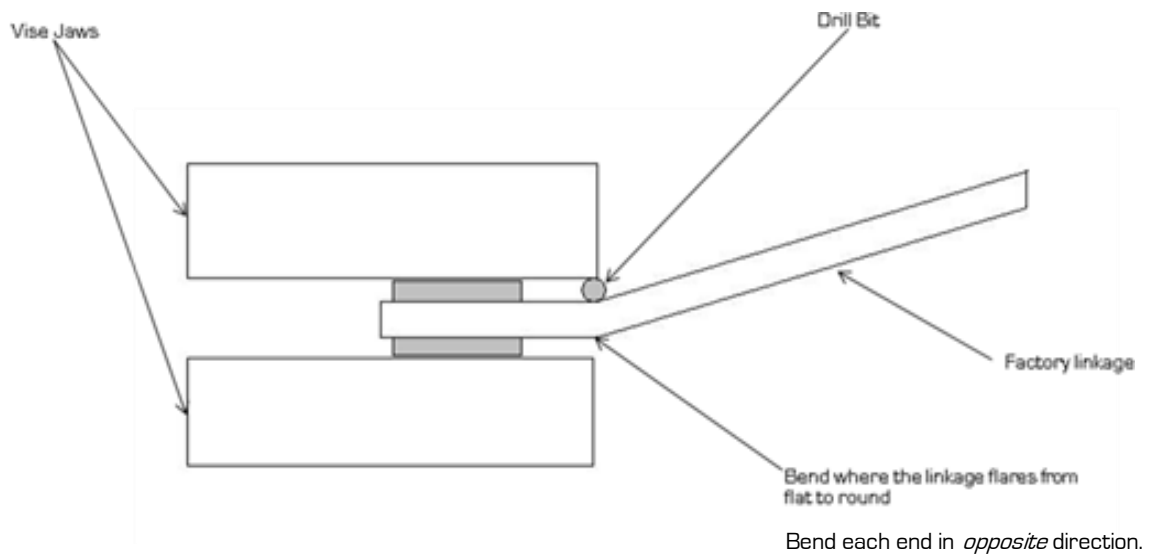

Figure 7 - Bending the Linkage Ends Properly

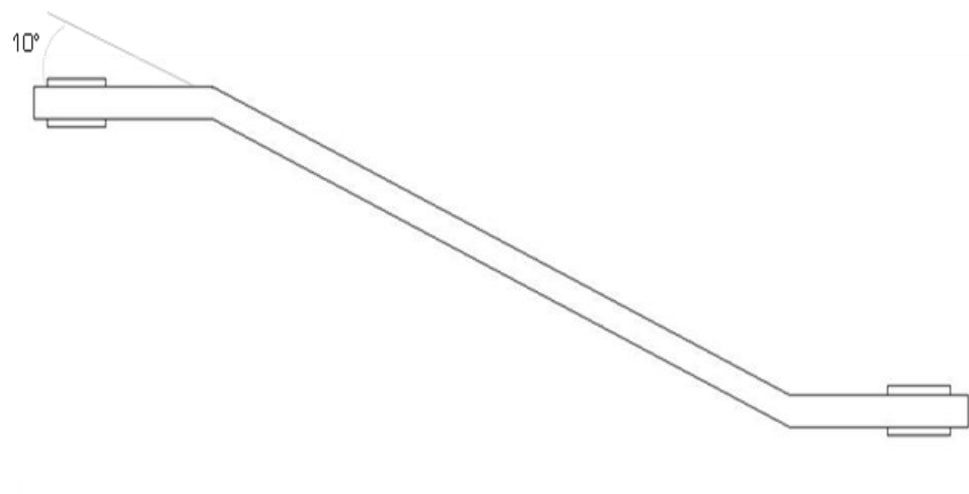

Figure 8 - Modified Wiper Linkage

- Reinstall the modified wiper linkage and attach it to the new pitman arm. Reuse the pitman arm clip that was removed in step 2. **NOTE: The Selecta-Speed wiper kit is shipped with the pitman arm in the "parked" position.** Do not move the pitman arm by hand to attach the wiper linkage. If the pitman arm is moved from the original "parked" position from Detroit Speed, it may result in the wiper blades stopping in the wrong spot on the windshield.
- Remove the stock wiper switch from the dash. The Selecta-Speed switch will replace the stock switch.
- Mount the switch in the dash. Use the Detroit Speed supplied hardware to mount the switch in the original dash location, if desired (Figure 9 on the next page).

Stock Dash Mount Illustration (all years)

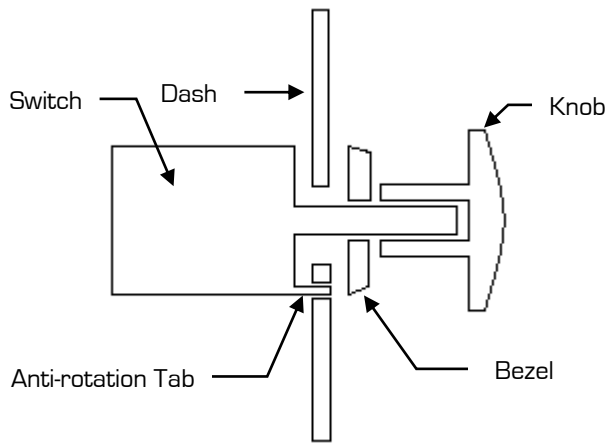

Figure 9a - Side View

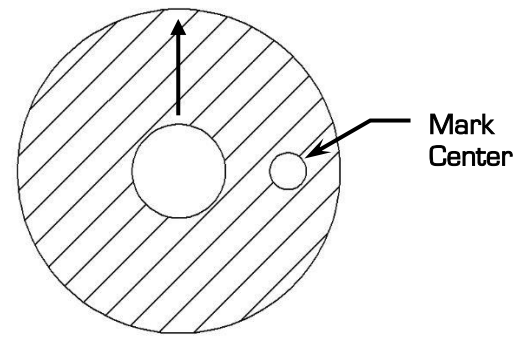

Figure 9b - Switch Mounting Template

Switch Mounting Instructions:

13. Cut the template out (Figure 9b above) and place it over the existing wiper switch hole in the dash. Make sure arrow is pointed up. [12 o'clock position]
14. Mark the center of the unshaded area of the template on the dash.
15. Remove the template and drill a 5/32" hole in the dash to accommodate the anti-rotation tab of the switch (Figure 10).



Figure 10 - Drill Anti-Rotation Hole

16. Install the wiper switch in the dash. (Figure 11). Make sure the anti-rotation tab on the switch passes through the hole in the dash that you drilled in step 15. Thread the bezel onto the switch shaft and tighten by hand to hold the switch in place on the dash (Figure 12).



Figure 11 - Install Wiper Switch



Figure 12 - Thread Bezel onto Switch

17. Slide the wiper knob onto the switch shaft. Align the set screw with the flat on the switch shaft and tighten (Figure 13). **NOTE:** Make sure the set screw locks onto the flat on the switch shaft.



Figure 13 - 1962-64 Chevy II Switch/Knob Installation

18. Install the wiper motor connector side of the wiring harness into the wiper motor (Figure 14).



Figure 14 - Wiper Motor Connector

19. The Detroit Speed Selecta-Speed harness does include a weather pack connector to install an optional electric inline washer pump into your vehicle (Figure 15). Detroit Speed does offer a washer pump kit you can purchase separately as part number 121102.



Figure 15 - Washer Pump Connection

20. If you have purchased the Detroit Speed washer pump kit, use the instructions from that kit to complete the washer pump kit installation. If you do not want to use the washer pump feature, you can tie wrap this connector/loom up under the dash.
21. With the wiper control module mounted in place, plug in the wiper switch and wiring harness connectors into the control module (Figure 16).

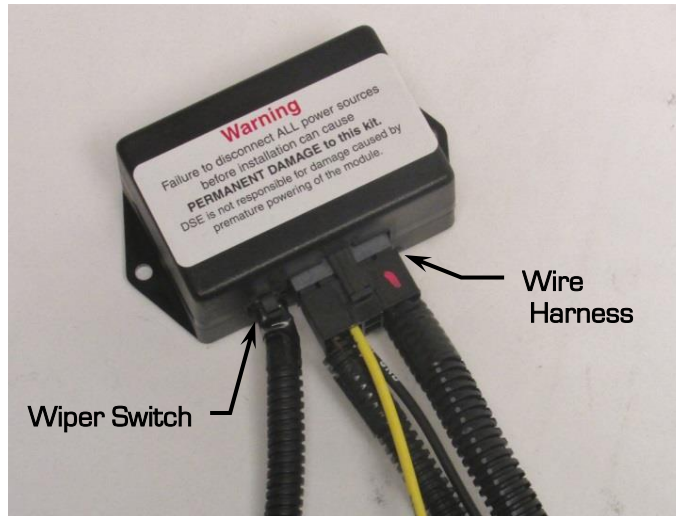

Figure 16 – Connect Wiper Switch & Harness to Module

22. Connect the yellow wire under the dash to a 12V ignition or accessory switched source. [Circuit is active when the key is in the run position]. This lead is supplied with an inline 30 amp ATO fuse.
23. Connect the black wire with the round eyelet under the dash to a ground. Make sure a proper ground is obtained by removing any rust or paint from the metal.
24. Connect the negative battery lead and test the wiper system. Upon a successful test, the conversion is complete. Secure the new wiring harness under the dash.

NOTE: In some cases high energy ignition systems have caused interference with the correct operation of the Selecta-Speed Wiper Kit due to spark plug wires routed closely to the wiper motor. If this occurs, re-routing your spark plug wires may be necessary.



1962-64 and
1965 "100 Series"
P/N: 121614



1965 "SS & 400 Series"
P/N: 121618



1966
P/N: 121616



1967
P/N: 121617

Figure 17 – Correct Knob/Bezel Combinations for Each Year

If you have any questions before or during the installation of this product, please contact Detroit Speed at tech@detroitsspeed.com or 704.662.3272

Legal Disclaimer: Detroit Speed is not liable for personal, property, legal, or financial damages from the use or misuse of any product we sell. The purchaser is solely responsible for the safety and performance of these products. No warranty is expressed or implied.