



FM2213PC/FM2214PC BBC Top Mount Alt, w/ A/C & Power Steering

| | |
|----------------------|--|
| Tools Required: | 9/16" Open-end wrench |
| 5/32" Allen wrench | 3/8-16 Thread chaser (If necessary) |
| 1/4" Allen wrench | 7/16-14 Thread chaser (If necessary) |
| 3/16" Allen wrench | New water pump to engine block gaskets |
| 5/16" Allen wrench | RTV silicone sealer |
| 1/2" Open-end wrench | Anti-seize |

Recommended Belt: Goodyear 6 Rib #4060605 (60.5") or Dayco #5060605 (60.5")

1) Disconnect battery & remove all existing accessory drive brackets and components from motor.

2) Remove water pump, scrape away any existing gasket material.

3) Clean and prep threads in cylinder heads, use a thread chaser if necessary (7/16-14 in passenger side head & engine block, 3/8-16 in driver side head and water pump). Thread chasers are available at your local auto parts store or tool dealer and are different from a thread cutting tool.

4) Thread the 3/8-16 x 2-1/2" threaded studs from the power steering skin board into the driver side water pump mount holes and tighten. The studs can easily be tightened by threading two 3/8-16 nuts (not included) onto the stud and tighten them against each other to act as a drive nut. Apply RTV sealer to engine block and water pump.

5) Install gaskets and then water pump. There should be no more than 5/8" of thread left exposed on studs. If more than 5/8" thread is showing, remove stud(s) and clean out threads then reinstall threaded stud(s) and check again. Apply anti-seize to the exposed threads on the studs. Also apply anti-seize to the threads of all the remaining fasteners at this time.

6) Thread the two 2" long spacer nuts (from the power steering kit) onto the exposed studs with the hex end out. Complete water pump installation by installing the passenger side water pump bolts. Tighten firmly.

7) Place the idler stand-off into the compressor bracket. Note: Idler stand off has an oval key that fits into like receptacle on bracket. Thread the 3/8-16 x 2-1/2" socket head cap screw through the back of the compressor bracket into the idler stand off bracket and tighten. This fastener will be torqued after the next step.

8) Attach the compressor bracket to the driver side cylinder head (outside holes nearest to the exhaust manifold) with the 3/8-16 x 3/4" socket head cap screw at the bottom of the bracket and the 3/8-16 x 1" socket head cap screw at the top of the cylinder head and tighten firmly (46 ft/lbs each). At this time, tighten the idler stand off bolt from step 7 (46 ft/lbs).

9) Attach the turnbuckle assembly to the top left boss on A/C bracket by threading a 3/8-16 x 1-1/4" socket head cap screw through the turnbuckle assembly and 3/16" load washer and into the compressor bracket, tighten firmly (46 ft/lb). Swing turnbuckle to rest on water pump.

10) At this time assemble the power steering bracket and pump assembly from the instructions provided with the power steering bracket beginning at step 8. Return to step 11 on this sheet when complete.

11) Install the compressor by aligning the compressor bosses with the compressor bracket, thread the 3/8-16 x 5" socket head cap screw through the compressor and bracket. Thread the 3/8-16 nut and 3/8" lock washer onto the back and finger tighten.

12) Thread the 3/8-16 x 1" socket head cap screw through the compressor ear (see figure) and into the 1-3/4" long front spacer nut and tighten. Swing the compressor up to match up the front spacer nut with the turnbuckle assembly, thread the 3/8-16 x 2-1/2" socket head cap screw through the rear compressor ear (see figure) and through the 1-1/16 spacer and turnbuckle assembly into the front spacer nut and tighten.

13) Place the stainless bearing sleeve into the 3-1/4" diameter idler pulley (long end of the sleeve goes into the bearing from backside of pulley). Insert assembly into the upper hole of the power steering bracket. Thread the 3/8-16 x 2-1/2" socket head cap screw with 3/8" x 7/8" OD stainless washer through the pulley and sleeve into the power steering bracket and tighten. Install the idler pulley cover with the three #10-32 x 1/2" socket head cap screws and tighten. Install the compressor cover with the three 1/4-20 x 3/4" socket head cap screws and tighten.

14) At this time install the alternator bracket and alternator using the instructions provided with the alternator bracket. Return to step 15 on this sheet after installation.

15) Install the alternator pulley with cover, water pump pulley with cover, and crankshaft pulley using the instructions provided with the pulley kit. Return to step 16 on this sheet when complete.

16) Route belt as shown in figure 2. Place bearing sleeve into 2-1/2" dia. pulley (long end of the sleeve goes into the bearing from backside of pulley). Place idler pulley on belt and push belt and pulley into position to line up with compressor bracket boss. Thread a 3/8-16 x 2-1/4" socket head cap screw with 3/8" x 7/8" OD stainless washer through the pulley and sleeve into the 1-1/2" aluminum Idler stand off. Tighten firmly (46 ft/lbs). Install idler pulley cover with three #10-32 x 1/2" socket head cap screws and tighten.

17) Adjust belt tension by twisting the two turnbuckle assemblies by hand until proper belt tension is achieved. Do not over-tighten belt! Serious damage may occur to the accessory drive bearings resulting in premature wear. Tighten jam nuts on turnbuckle. Tighten alternator socket head cap screws (46 ft/lbs). Tighten compressor socket head screws (46 ft/lbs) and compressor swivel bolt and nut with lock washer firmly. Re-check belt tension.

18) Reconnect electrical and install A/C lines and fittings. Caution: Do not connect A/C compressor electrical until system is properly charged. Test run motor and re-check belt tension, adjust if necessary. Re-check belt tension after 100 miles.





FM2213PC/FM2214PC BBC Top Mount Alt, w/ A/C & Power Steering

Fasteners shown are for A/C compressor bracket assembly. Refer to Alternator, Power Steering, & Pulley Installation instructions for additional information.

Tools Required:

- 5/32" Allen wrench
- 1/4" Allen wrench
- 3/16" Allen wrench
- 5/16" Allen wrench
- 1/2" Open-end wrench
- 9/16" Open-end wrench
- 3/8-16 Thread chaser (If necessary)
- 7/16-14 Thread chaser (If necessary)
- New water pump to engine block gaskets
- RTV silicone sealer
- Anti-seize

Recommended Belt: Goodyear 6 Rib #4060605 (60.5") or Dayco #5060605 (60.5")

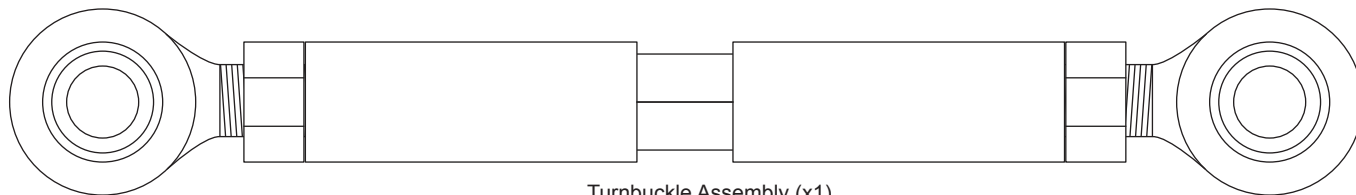

Turnbuckle Assembly (x1)

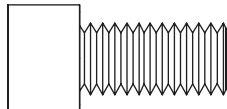

3/8-16 x 3/4" Socket Head Cap Screw (x1)

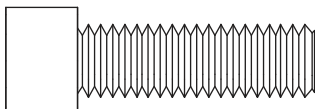

3/8-16 x 1-1/4" Socket Head Cap Screw (x1)

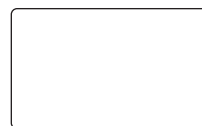

1-1/16" Rear Spacer (x1)

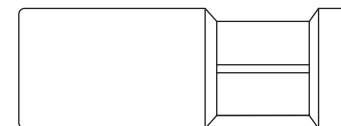

1-3/4" Front Spacer (x1)

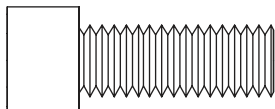

3/8-16 x 1" Socket Head Cap Screw (x1)

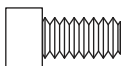

#10-32 x 1/2" Socket Head Cap Screw (x6)

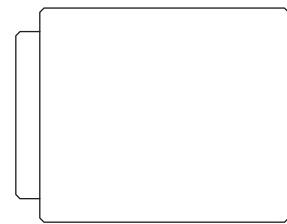

Idler Stand-Off (x1)

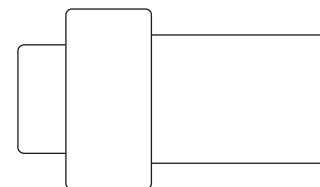

Bearing Sleeve (x2)

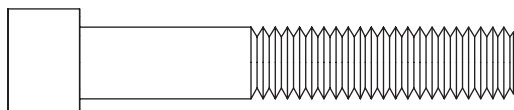

3/8-16 x 2-1/4" Socket Head Cap Screw (x1)

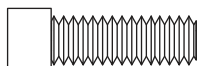

1/4-20 x 3/4" Socket Head Cap Screw (x3)

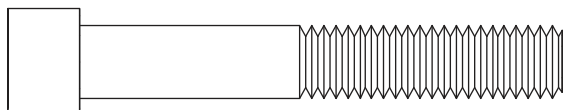

3/8-16 x 2-1/2" Socket Head Cap Screw (x3)

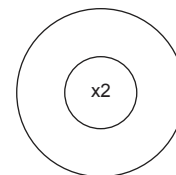

3/8 x 7/8" Flat Washer

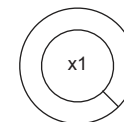

3/8" Lock Washer

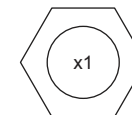

3/8"-16 Hex Nut

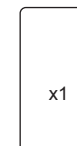

3/16" Load Washer



3/8-16 x 5" Socket Head Cap Screw (x1)





FM2213PC/FM2214PC BBC Top Mount Alt, w/ A/C & Power Steering

Figure 2: BELT PATH

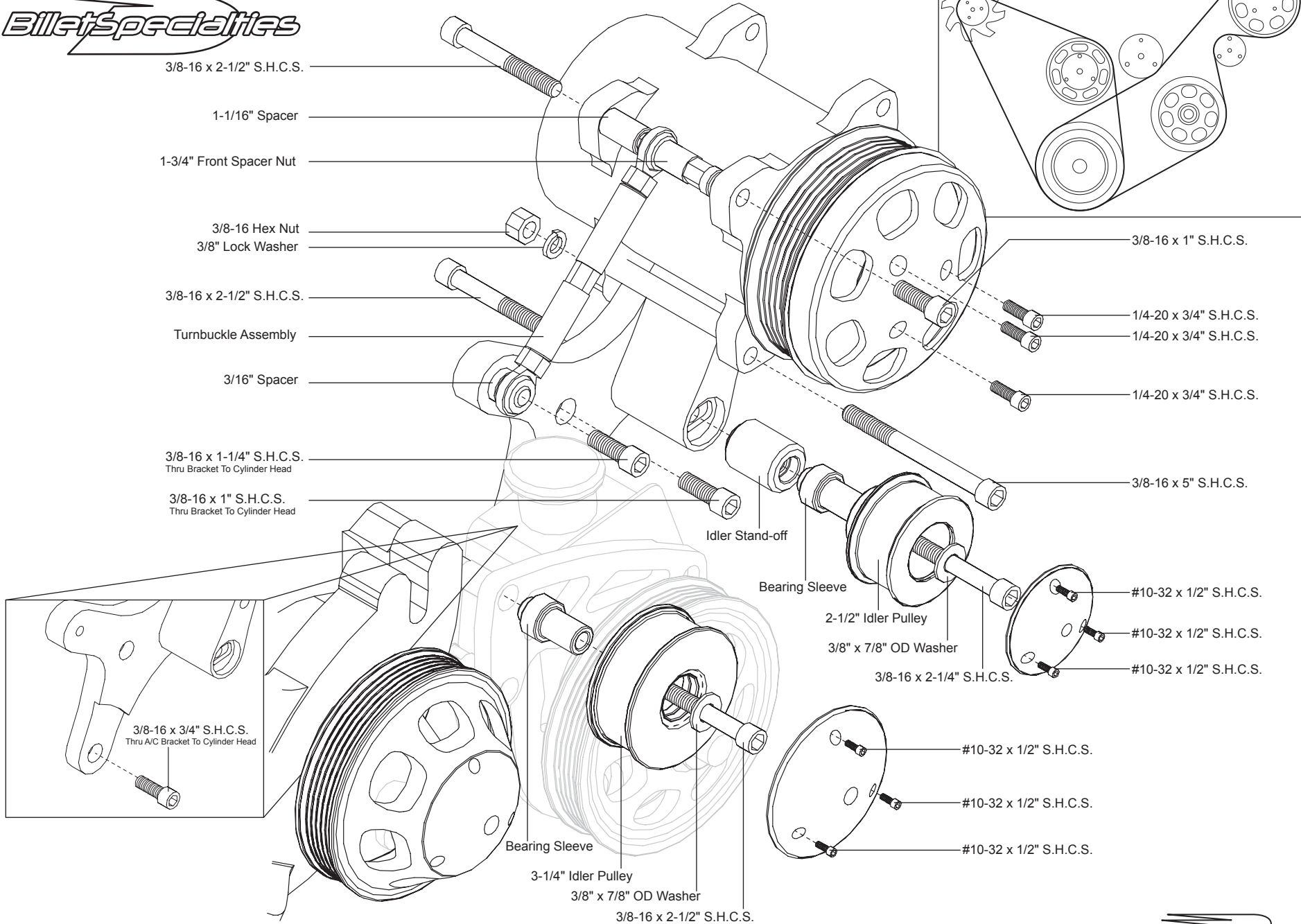



FM0209PC BBC Top Mount Alternator Bracket

Tools Required:

- | | |
|----------------------|--------------------------------------|
| 1/4" Allen Wrench | 9/16" Open End Wrench |
| 5/16" Allen wrench | 7/16-14 Thread Chaser (If necessary) |
| 1/2" Open End Wrench | Anti-Seize |

We recommend applying Anti-Seize to all threads when assembling bracket.

Recommended Belt: Goodyear 6 Rib #4060460 (46") or Dayco #5060460 (46.1")

- 1) Disconnect battery & remove existing accessory drive brackets.
- 2) Clean & prep threads in passenger cylinder head (outside hole) and left side of water pump. Run a 7/16-14 thread chaser if necessary. Thread chasers are available at your local auto parts store or tool dealer and are different from a thread cutting tool.
- 3) Thread the 7/16-14 x 1-1/4" threaded stud into the outside passenger side cylinder head and finger tighten. For aftermarket cylinder heads with 3/8" tapped holes use the included 3/8 to 7/16 adapter. There should be no more than 5/8" of thread left exposed. (if more than 5/8" thread is showing, remove stud and clean out threads then reinstall threaded stud and check again) Apply anti-seize to the exposed threads on the stud. Also apply anti-seize to the threads of all the remaining fasteners at this time.
- 4) Thread the 3-11/32" spacer nut onto the exposed stud and tighten firmly.
- 5) Attach the alternator bracket to the water pump with the two 3/8-16 x 3/4" stainless socket head cap screws and finger tighten.
- 6) Thread the 3/8-16 x 1-1/4" stainless socket head cap screw through one end of the turnbuckle assembly and the 3/16" spacer into the water pump boss and tighten firmly. Swing the turnbuckle to the right and lay to rest out of the way.
- 7) Attach the alternator ear bracket to the top alternator boss with the 5/16-18 x 3/4" stainless socket head cap screw and tighten (26 ft./lb.).
- 8) Place the alternator between the spacer nut and alternator bracket and thread the 3/8-16 x 2-3/4" stainless socket head cap screw through the Alternator bracket & alternator into the spacer nut and finger tighten.
- 9) Swing the alternator up into position and match up to the turnbuckle assembly, thread the 3/8-16 x 1" through the turnbuckle rod end into the alternator ear bracket and tighten (46ft./lb.).
- 10) Route belt around alternator, water pump and crank pulleys. Twist turnbuckle by hand until proper belt tension is achieved. Do not over-tighten belt! Serious damage may occur to the accessory drive bearings resulting in premature wear.
- 11) Tighten jam nuts on turnbuckle. Tighten alternator socket head screw (46ft./lb.) Tighten alternator bracket screws on water pump (46ft./lb.) Re-check belt tension.
- 12) Reconnect electrical and test run motor. Re-check belt tension after 100 miles.

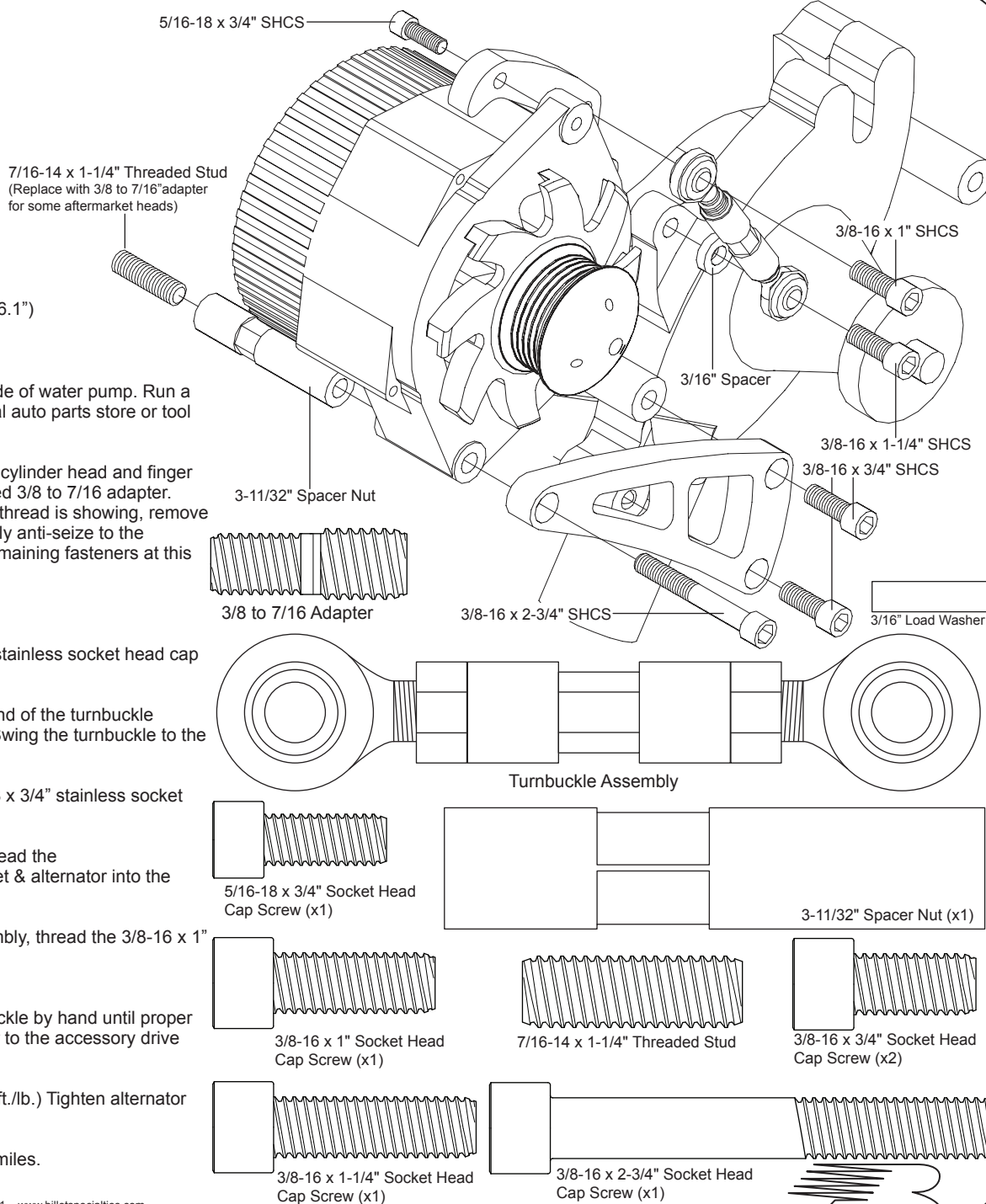



FM0230PC BBC Power Steering Bracket

| | |
|-----------------------|--|
| Tools Required: | 3/8-16 Thread chaser (If necessary) |
| 5/16" Allen wrench | 7/16-14 Thread chaser (If necessary) |
| 3/8" Allen wrench | New water pump to engine block gaskets |
| 1/2" Open-end wrench | RTV silicone sealer |
| 9/16" Open-end wrench | Anti-seize |

It is recommended that you use the proper tools to remove and install the power steering pulley. KD Tools P/N2897 puller and installer set or similar will insure proper pulley service. Some auto parts stores rent out tool sets.

Recommended Belt: Goodyear 6 Rib #4060385 (38.5")* or Dayco #5060388 (38.8")*

*If running power steering only

- 1) Disconnect battery, drain coolant, & power steering fluids. Disconnect coolant & power steering lines. Remove all existing accessory drive brackets and components from motor.
- 2) Remove existing power steering bracket and pulley (press on pulleys require the use of a special puller to avoid damage to power steering pump and pulley – see tool list)
- 3) Remove water pump, scrape away any existing gasket material.
- 4) Clean and prep threads in cylinder heads, use a thread chaser if necessary. 7/16-14 in engine block & 3/8-16 in water pump. Thread chasers are available at your local auto parts store or tool dealer and are different from a thread cutting tool.
- 5) Thread the 3/8-16 x 2-1/2" threaded studs from the power steering skin board into the driver side water pump mount holes and tighten. The studs can easily be tightened by threading two 3/8-16 nuts (not included) onto the stud and tighten them against each other to act as a drive nut. Apply RTV sealer to engine block and water pump.
- 6) Install gaskets and then water pump. There should be no more than 5/8" of thread left exposed on studs. If more than 5/8" thread is showing, remove stud(s) and clean out threads then reinstall threaded stud(s) and check again. Apply anti-seize to the exposed threads on the studs. Also apply anti-seize to the threads of all the remaining fasteners at this time.
- 7) Thread the two 2" long spacer nuts (from the power steering kit) onto the exposed studs with the hex end out and install the passenger side water pump bolts to complete installation of water pump. Tighten firmly.
- 8) Attach the steel three hole power steering bracket to the front of pump with two 3/8-16 x 3/4" socket head cap screws and tighten firmly (46 ft/lb). Attach steel adjustment bracket to the back of the power steering pump with one 3/8-16 x 3/4" socket head cap screw and finger tighten.
- 9) Place pump assembly on motor and align three hole steel bracket with water pump boss by the spacer nuts. Thread the 1/2-13 x 3/4" socket head cap screw through the bracket and into the water pump and finger tighten.

Swing the rear steel bracket up and align with engine block lower mount boss, thread a 7/16-14 x 1-1/2" socket head cap screw through the thin 7/16" ID slide spacer, the rear steel bracket and the 21/32" long rear spacer into the engine block and finger tighten. Note: the spacers have a lip that locates them in the adjustment slot of the bracket.

10) Thread a 3/8-16 x 1" socket head cap screw through one thin 3/8" ID slide spacer, the aluminum power steering bracket and one more thin 3/8" ID slide spacer and into the power steering pump. Finger tighten.

11) Thread the two remaining 3/8-16 x 3/4" socket head cap screws through the aluminum bracket and into the water pump spacer nuts and tighten firmly (46 ft/lbs). Do not install top bolt if installing kits with A/C #FM2213PC or #FM2214PC.

12) Install pulley:

For pumps with a keyed shaft – Place the pulley onto shaft, install thrust washer and nut. Tighten nut.

For Pumps with a press on shaft – Always use a pump pulley installer to push the pulley onto the shaft. The hub of the pulley should be flush with the end of the pump drive shaft. Follow the instructions provided with the pulley installation tool.

Do not press or hammer the pulley onto the shaft, this will destroy the pump.

13) For bracket kits that are included with a serpentine conversion kit skip the next step and go on to step 15

14) Install belt (38-1/2" recommended); adjust belt tension by moving pump in brackets. When proper belt tension has been achieved, tighten all fasteners firmly. Check belt tension again and adjust if necessary. Do not over tighten belt! Serious damage may occur to the accessory drive bearings resulting in premature wear. Go to step 16.

15) Only if you have purchased a complete serpentine conversion kit. Align pump so that the fill cap is level, tighten all fasteners firmly. Install power steering lines and fittings at this time. Return to the main kit instructions at this time.

16) Install power steering lines and fittings, inspect hoses for kinks or nicks and replace as necessary. Fill reservoir to the proper level and test run motor. Re-check belt tension and adjust if necessary. Re-check belt tension after 100 miles.

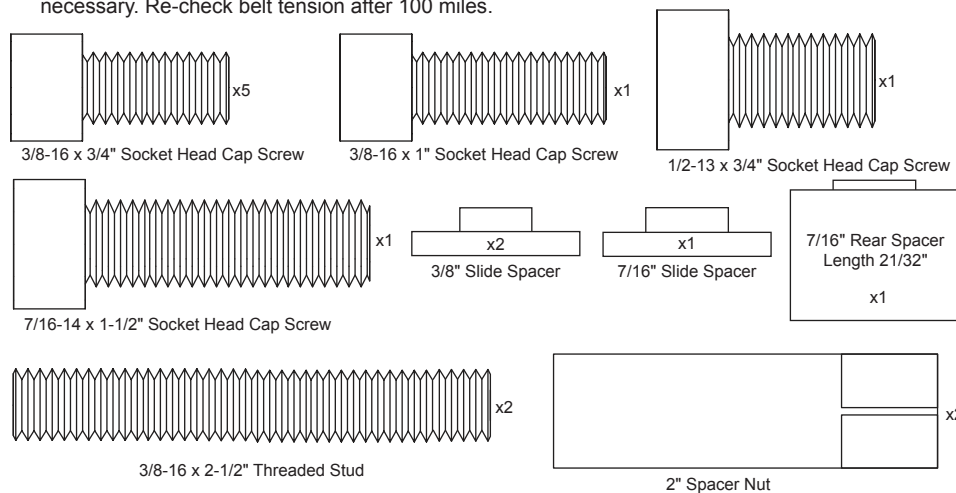



FM0230PC BBC Power Steering Bracket

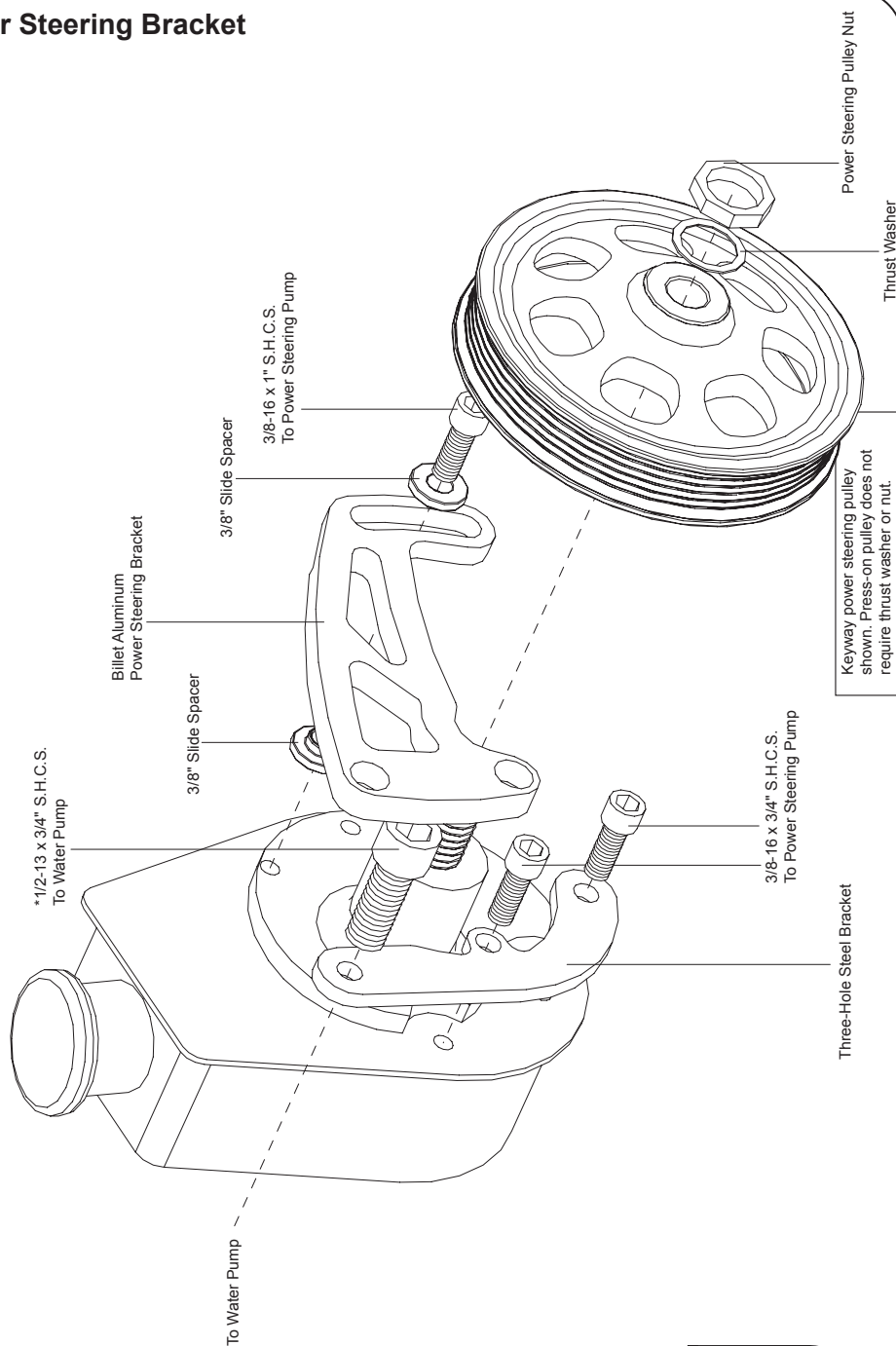
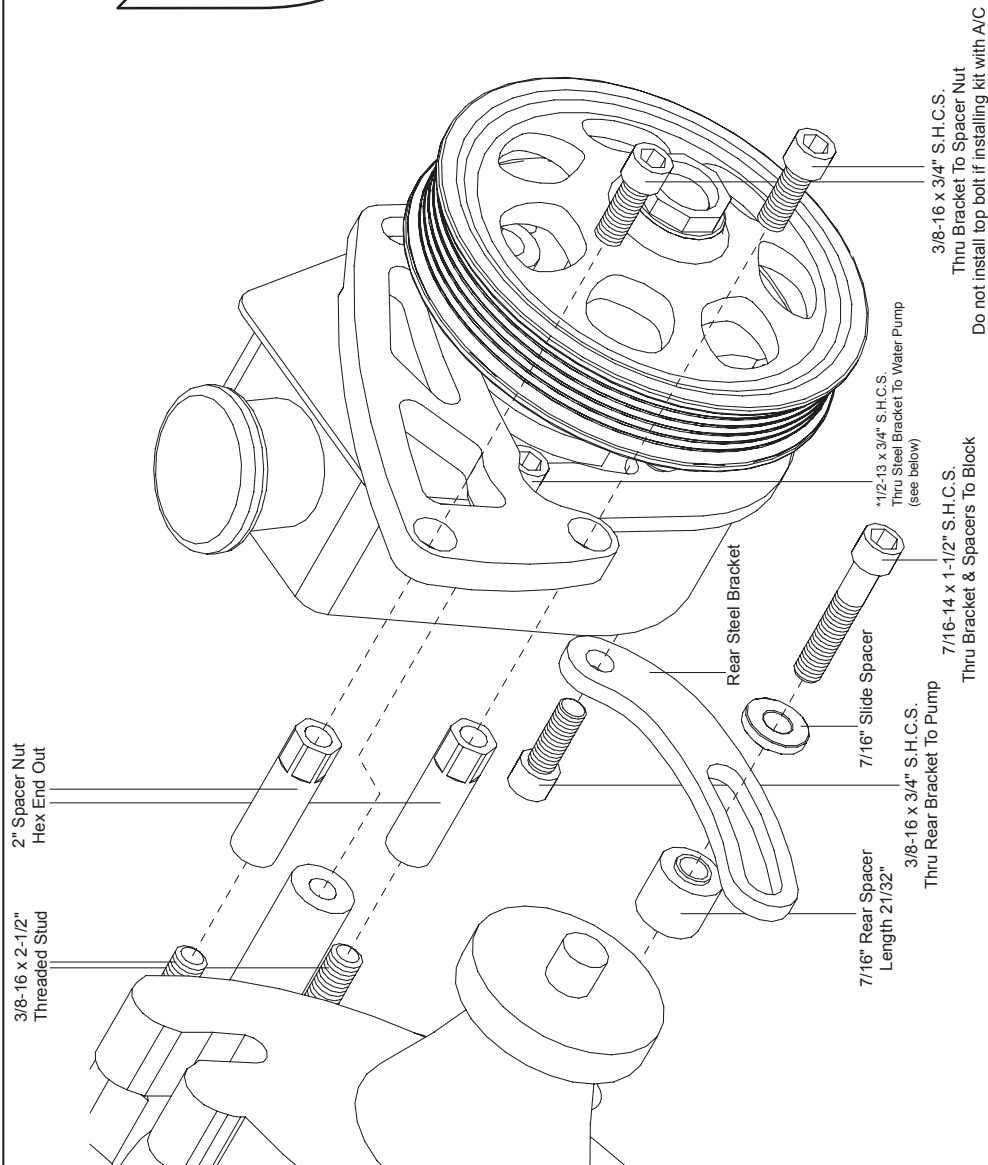



FM3210PC BBC Serpentine Pulley Kit - LWP

ALTERNATOR PULLEY

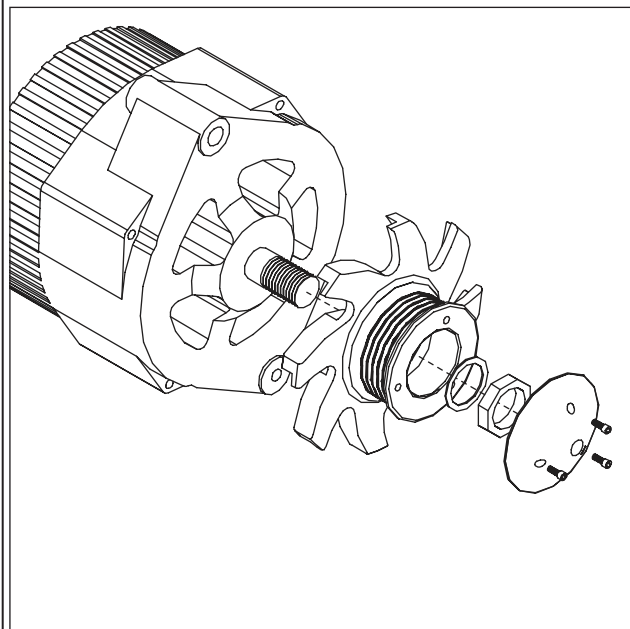
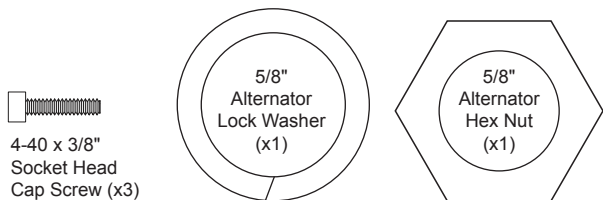

Tools Required:
3/32" Allen wrench
15/16" Socket

WATER PUMP PULLEY

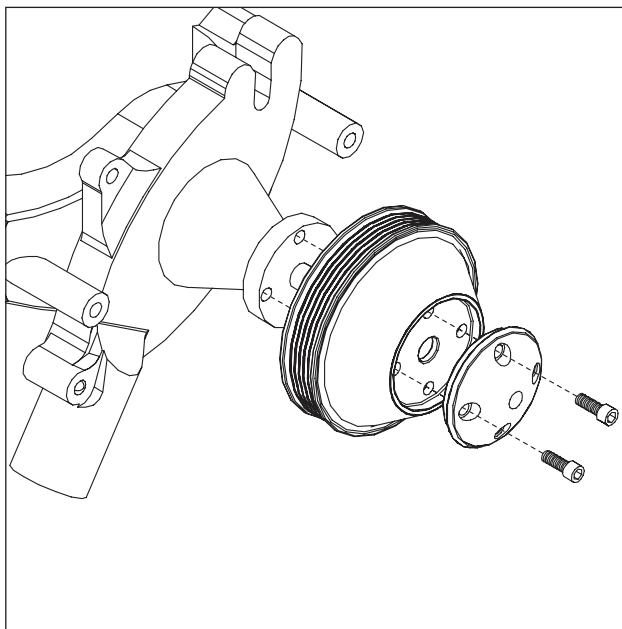
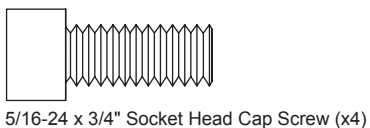

Tools Required:
1/4" Allen wrench

CRANKSHAFT PULLEY

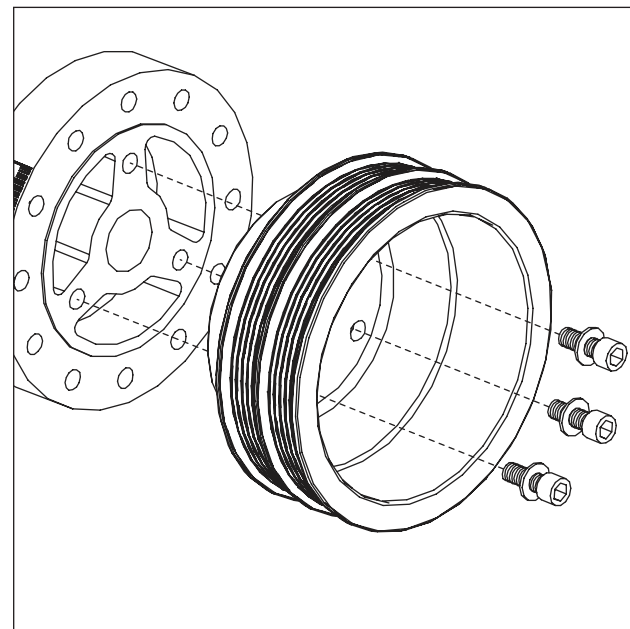
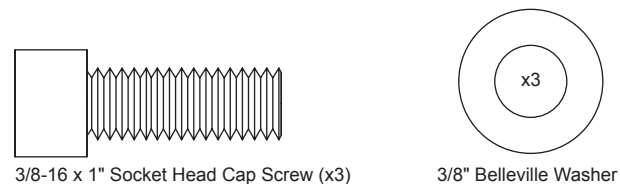

Tools Required:
5/16" Allen wrench

