



'55 '56 '57 (Tri-Five) Chevy Brake/Clutch Pedal #199350 / #199355

Tools Needed:

- 3/32" drill bit
- 5/16" drill bit
- Spray Adhesive
- Center punch
- 7/16" wrench

1. Remove rubber pedal pad
2. Cut out template and apply spray adhesive to the back, align template with pedal and attach.
3. Center punch the pedal in the center of the holes as marked on the template. Four options are provided for manufacturing variations; check pedal arm location as to which holes to drill.
4. Drill 3/32" pilot holes in each center punch, follow by drilling with 5/16" drill bit.
5. Install 1/4"-20 socket set screw in appropriate holes in billet pedal cover, install billet pedal cover on pedal then attach washer and lock nut. Tighten firmly by alternating turns at each nut with 7/16" wrench.
Extra hardware is provided – just in case.

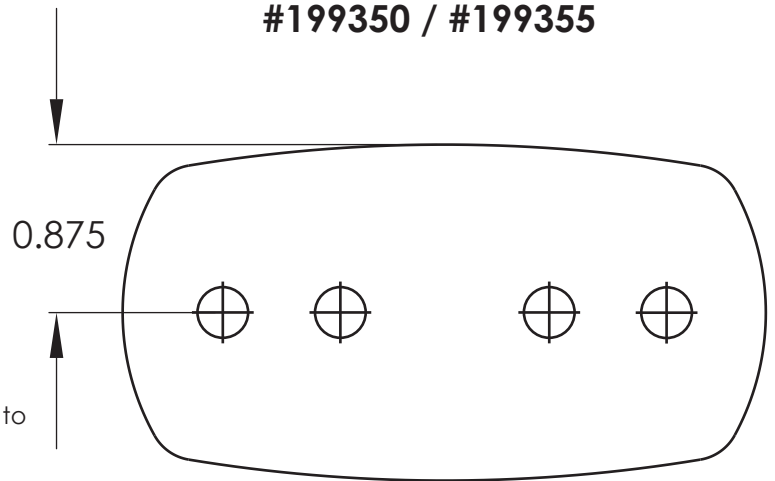

Due to multiple sources used by the auto manufacturer, some pedals may have to be trimmed for the pedal cover to fit properly.



'55 '56 '57 (Tri-Five) Chevy Brake/Clutch Pedal #199350 / #199355

Tools Needed:

- 3/32" drill bit
- 5/16" drill bit
- Spray Adhesive
- Center punch
- 7/16" wrench

1. Remove rubber pedal pad
2. Cut out template and apply spray adhesive to the back, align template with pedal and attach.
3. Center punch the pedal in the center of the holes as marked on the template. Four options are provided for manufacturing variations; check pedal arm location as to which holes to drill.
4. Drill 3/32" pilot holes in each center punch, follow by drilling with 5/16" drill bit.
5. Install 1/4"-20 socket set screw in appropriate holes in billet pedal cover, install billet pedal cover on pedal then attach washer and lock nut. Tighten firmly by alternating turns at each nut with 7/16" wrench.
Extra hardware is provided – just in case.

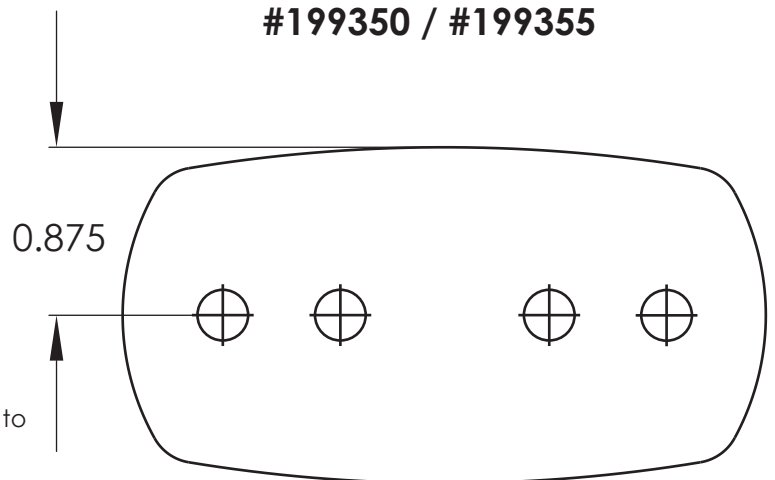

Due to multiple sources used by the auto manufacturer, some pedals may have to be trimmed for the pedal cover to fit properly.

