



FOR CONVERSION FROM FACTORY THROTTLE LINKAGE
TO CABLE STYLE THROTTLE

'55 '56 '57 (Tri-Five) Chevy Gas Pedal #199150 / #199155

Tools Needed:

- 5/32" Allen Wrench
- 3/8" Wrench
- Loc-tite® Thread Locker
- 77/16" Wrench
- 5/16" drill bit

Also required but not included:

- Throttle cable and housing

1. Disconnect Battery. Disconnect throttle linkage arms from carburetor and firewall, remove and set aside. Remove throttle linkage pivot base from firewall with 3/8" or 7/16" wrench, remove accelerator pedal from inside of vehicle. Save the fasteners for later use.

2. Install the gas pedal pedestal through the firewall and into the interior of the vehicle, secure with the two fasteners removed from the pivot base. (It is recommended to apply a thin bead of RTV Silicone around the pedestal base to seal out the elements). Tighten firmly.

3. Install the gas pedal components as shown in the illustration and finger tighten.

4. Remove carpet and or insulation from floorboard/firewall that may be in the way of where the upper arm comes in contact.

5. Remove the clevis and nut from throttle cable (not included). Temporarily install clevis on gas pedal upper arm. Push upper arm with clevis and nut for proper spacing against firewall and mark position. Find center and drill a small pilot hole followed by 5/16" bit.

6. Install throttle cable (not included) per manufacturer's instructions. Aluminum beveled washers correct the angle of the factory firewall. They are installed on both sides of the firewall and are held in place with the aluminum ferule and nut supplied on the end of the throttle cable.

7. Adjust gas pedal lower arm angle to your liking and apply Loc-Tite® to the threads of the flat head cap screw and tighten firmly. Gas pedal should not bind in any way, Pedal operation should be smooth.

8. Replace carpet and or insulation.

Other Adjustments Include:

- Gas pedal has two axle pivot options to adjust pedal up and down on arm.
- Lower gas pedal arm can be flipped for added floor clearance.

Billet Specialties, Inc. 500 Shawmut Avenue La Grange, Illinois 60526 PH 800.245.5382 Fax 708.588.7181 www.billetpecialties.com

1/4-20 x 1/2"
F.H.C.S.



Aluminum
Washer



Delrin
Bushing



Gas Pedal
Upper Arm



Shim
Washers



Splined
Bushing

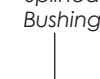

Delrin
Bushing



Gas Pedal
Pedestal



Gas Pedal
Lower Arm

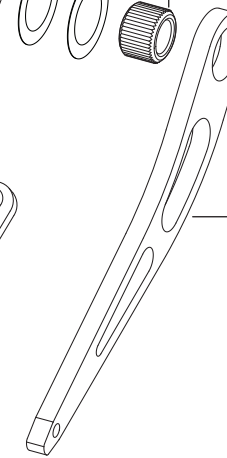

Gas Pedal Pad

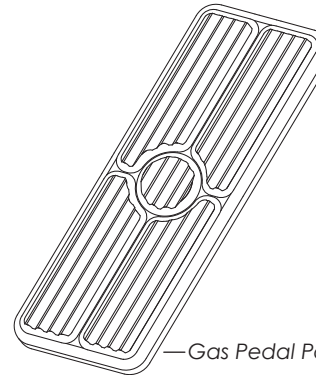

E-Clips



Axle Pivot



Tension Spring

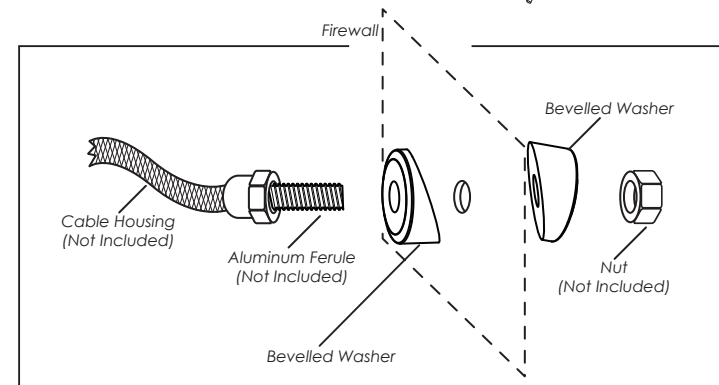

IMPORTANT

- Check throttle operation before starting vehicle. Gas pedal operation should be smooth and not bind in any way.