

TM

# Tru Trac

## 326/455 Pontiac

Installation Manual  
For Systems With A/C  
#14900 / #14920

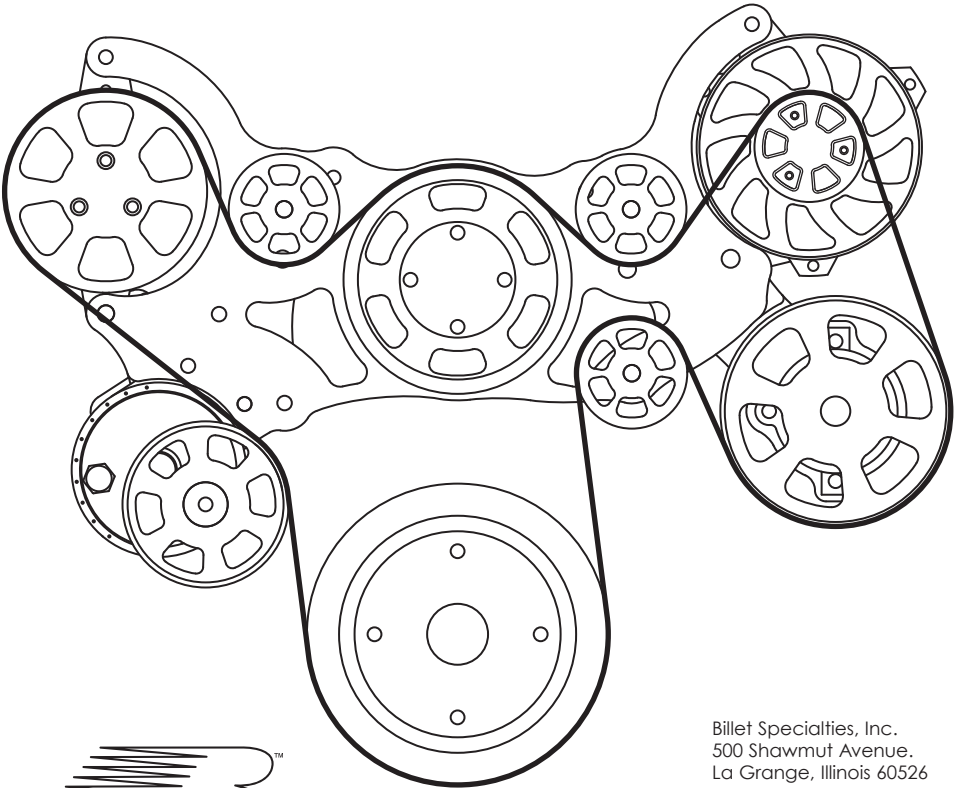

Billet Specialties, Inc.  
500 Shawmut Avenue.  
La Grange, Illinois 60526  
Tech Line (708) 588-0505  
Fax (708) 588-7181

# PLEASE READ ALL INSTRUCTIONS BEFORE INSTALLING ANY COMPONENTS OF THE TRU TRAC SERPENTINE SYSTEM

Tech Line: 708.588.0505  
 Fax: 708.588.7181  
[www.billet specialties.com](http://www.billet specialties.com)

## Required Tools & Materials

- |  |  |                                      |
|--|--|--------------------------------------|
| <input type="checkbox"/> Anti-seize Compound               | <input type="checkbox"/> 5/8" Combo Wrench         | <input type="checkbox"/> 3/16" Allen |
| <input type="checkbox"/> RTV Silicone                      | <input type="checkbox"/> 11/16" Combo Wrench       | <input type="checkbox"/> 7/32" Allen |
| <input type="checkbox"/> Permatex Hylomar® Gasket Dressing | <input type="checkbox"/> Socket Wrench & Extension | <input type="checkbox"/> 1/4" Allen  |
| <input type="checkbox"/> Gasket Scraper                    | <input type="checkbox"/> 3/8" 12pt. socket         | <input type="checkbox"/> 5/16" Allen |
| <input type="checkbox"/> Scotch-Brite® Pad                 | <input type="checkbox"/> 10mm 12pt. socket         |                                      |
|  | <input type="checkbox"/> 12mm 12pt. socket         |                                      |

### TECH TIP:

Billet Specialties recommends the use of Anti-Seize on all fasteners to prevent thread lock-up.

## Prepping The Block:

- Disconnect battery.
- Remove all existing accessory drive brackets and components from motor.
- Remove water pump and divider plate.
- Scrape away gasket material and dress surface with a Scotch Brite® pad.
- Clean and inspect timing cover surface for pitting or other issues that may cause a leak.

• Now is a good time to replace the water pump sleeves to ensure proper cooling. Water pump sleeves are available at most auto parts stores or Pontiac specialty shops GM P/N 9796347.



### Skin Board #1 - Packaged with Power Steering Pump

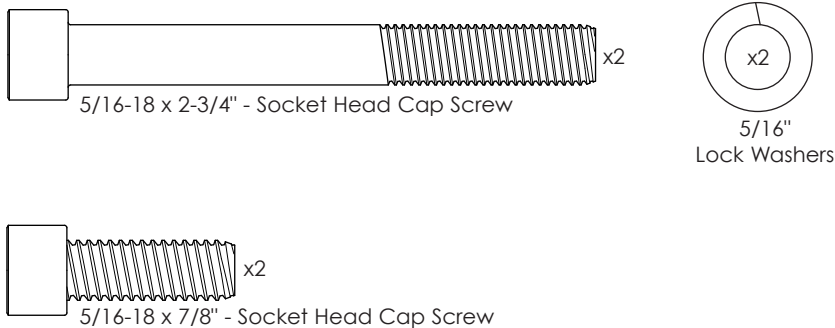

### Skin Board #2 - Packaged with Water Pump

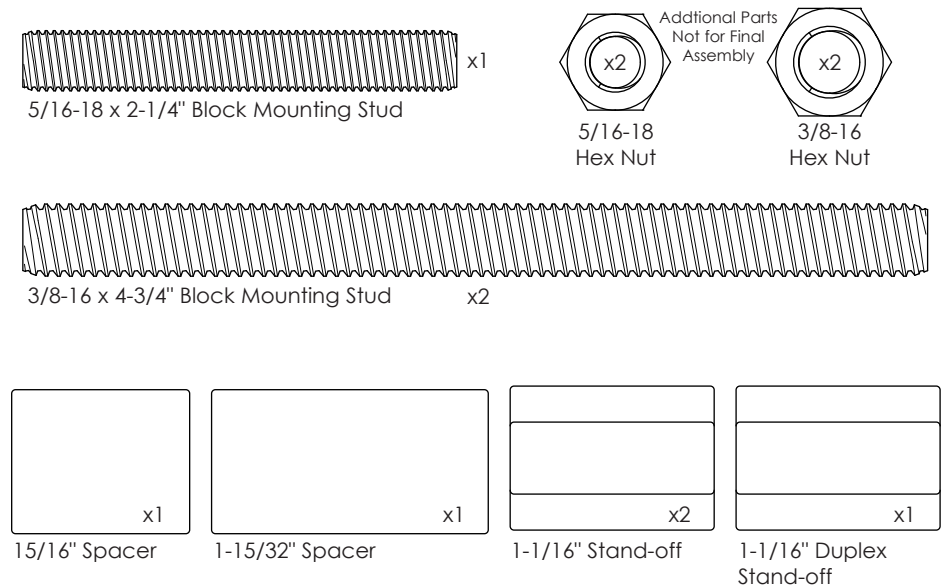

### Skin Board #3 - Packaged In Main Box

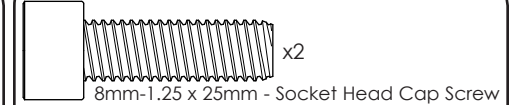
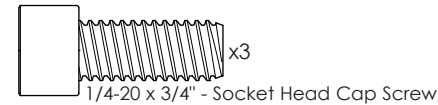
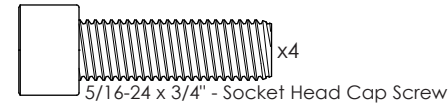
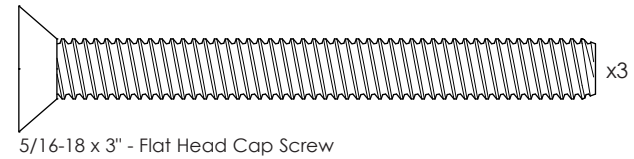
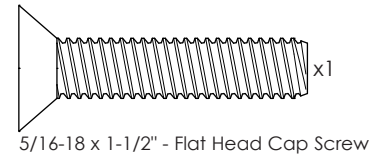
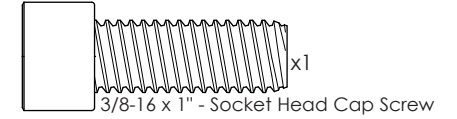
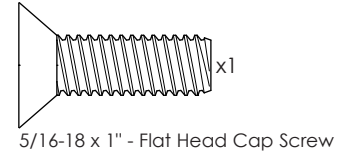
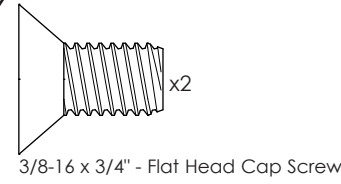
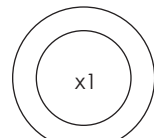
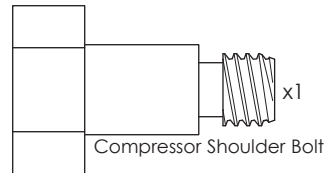
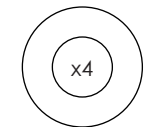
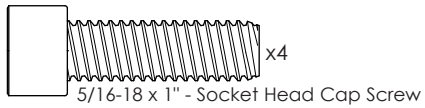
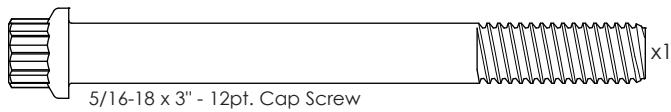
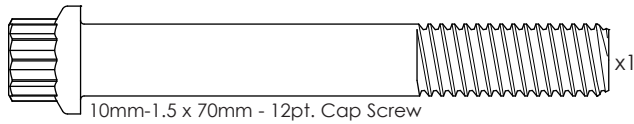
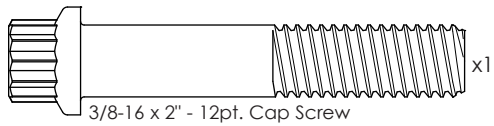
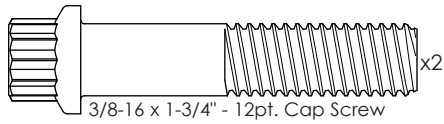
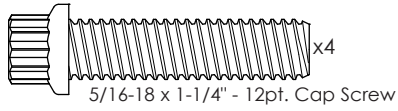
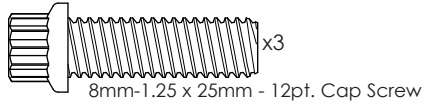
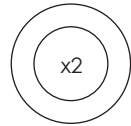
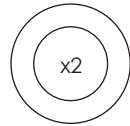
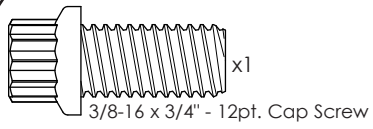

### Other Hardware - Packaged With Power Steering Pump

Goodyear Poly-V Serpentine Belt - 74.75" #4060747 (with power steering)

Goodyear Poly-V Serpentine Belt - 63.50" #4060635 (without power steering)

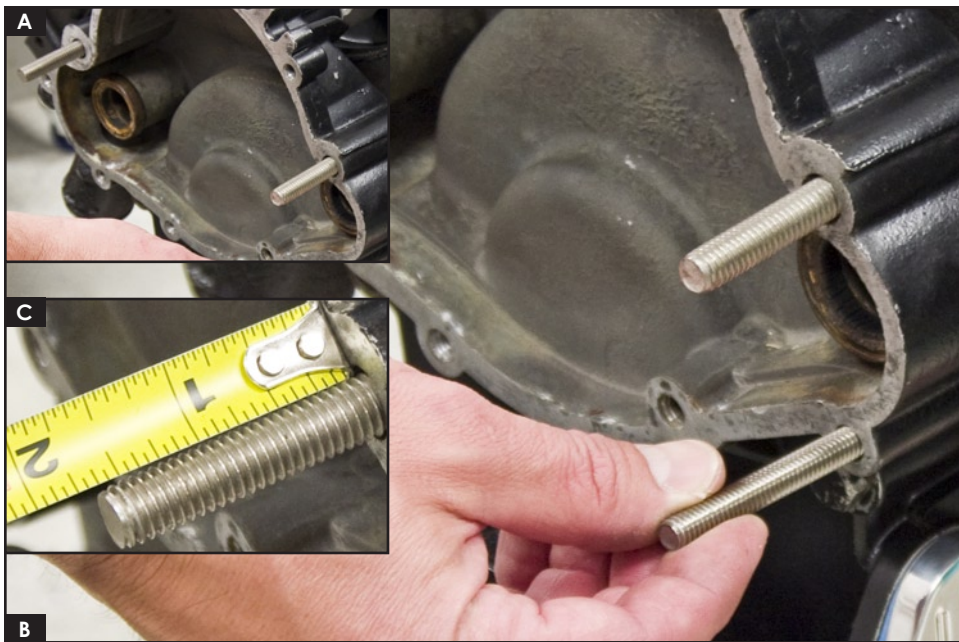

**Figure 1: Prepare Timing Cover**

**[A]** Thread the two 3/8-16 x 4-3/4" threaded studs through the timing cover and into the block as shown.

**[B]** Thread the single 5/16-18 x 2-1/4" threaded stud into the timing cover as shown.

Each stud should extend 1-5/8" beyond the timing cover. If the studs exceed the specified length the threads in the engine block/timing cover will need to be cleaned out until the stud threads are within spec. Attempts to install the Tru Trac with the studs exceeding this length will not allow critical components to line up or tighten correctly.

**Example:** The studs can easily be tightened by threading two 3/8"-16 or 5/16"-18 zinc coated nuts onto the stud and tighten them against each other to act as a drive nut. The zinc coated nuts may be discarded after this step.

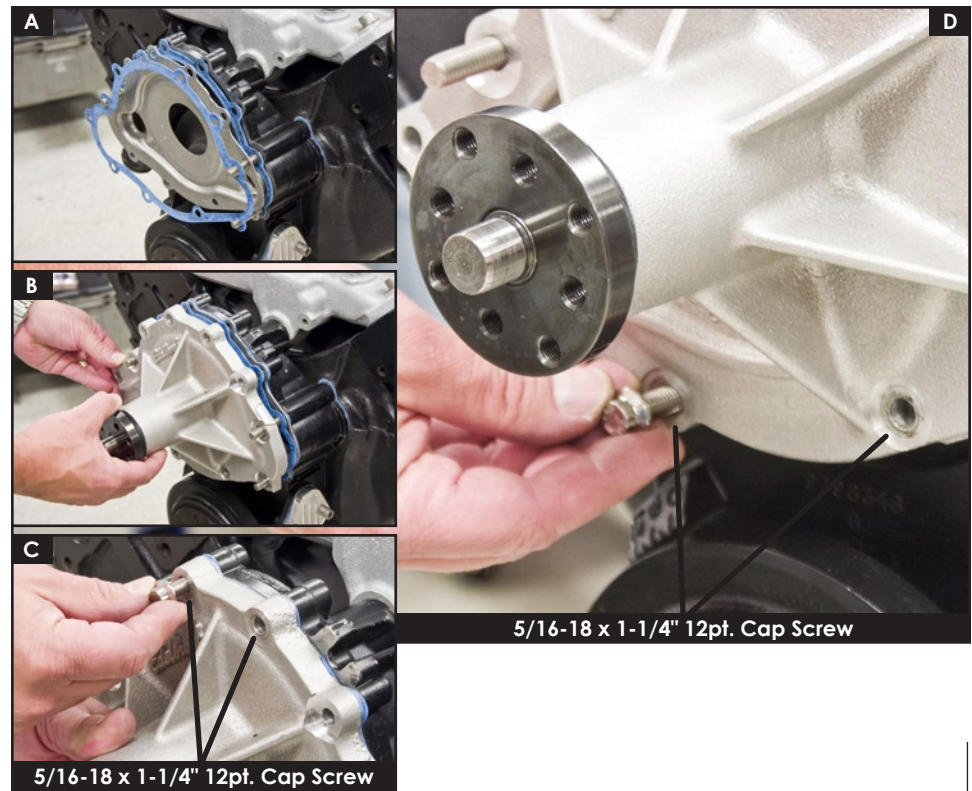
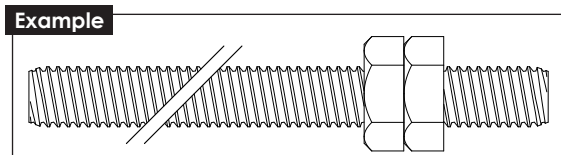

**Figure 2: Install The Water Pump**

Coat both sides of each water pump gasket with Permatex Hylomar® gasket dressing.

**[A]** Install water pump divider plate with a gasket on each side.

**[B]** Install water pump to timing cover.

Apply anti-seize to four 5/16-18 x 1-1/4" 12 pt. cap screws.

**[C]** Thread two of the 5/16-18 x 1-1/4" 12 pt. cap screws through the top two holes in the water pump and finger tighten.

**[D]** Follow by threading the other two 5/16-18 x 1-1/4" 12 pt. cap screws in the bottom holes of the water pump and finger tighten.

Apply anti-seize to the exposed treads of the threaded studs from Figure 1.

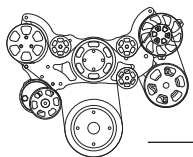



**Figure 3: Install Power Steering Bracket**

For kits without power steering continue to Figure 4.

Locate the power steering bracket and the alternator bracket.

Apply anti-seize to the two 5/16-18 x 7/8" socket head cap screws.

**[A]** Attach the power steering bracket to the back of the alternator bracket with the two 5/16-18 x 7/8" socket head cap screws. Tighten firmly.

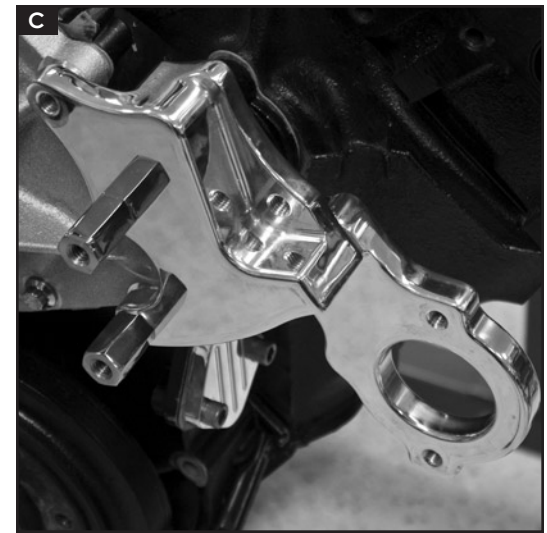
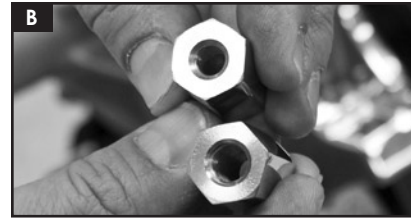
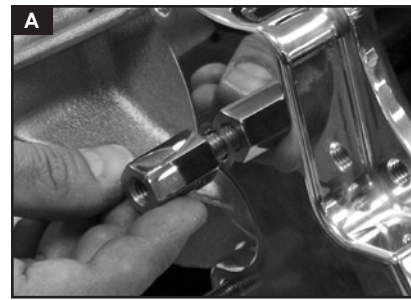

**Figure 4: Install Alternator Bracket**

**[A]** Attach to the driver side of motor as shown using one 1-1/16" stand off on the top stud and finger tighten.

**[B]** Follow by installing the special 1-1/16" duplex stand off on the smaller 5/16" stud below. This standoff is identified by one large threaded hole (3/8") and a smaller hole on the other side (5/16").

**[C]** The larger hole (3/8") will face outward, tighten both spacers firmly.

At this time tighten the four 5/16-18 x 1-1/4" 12 pt. cap screws installed in Figure 2 (21 ft/lbs).

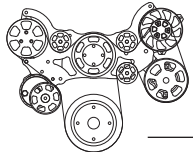

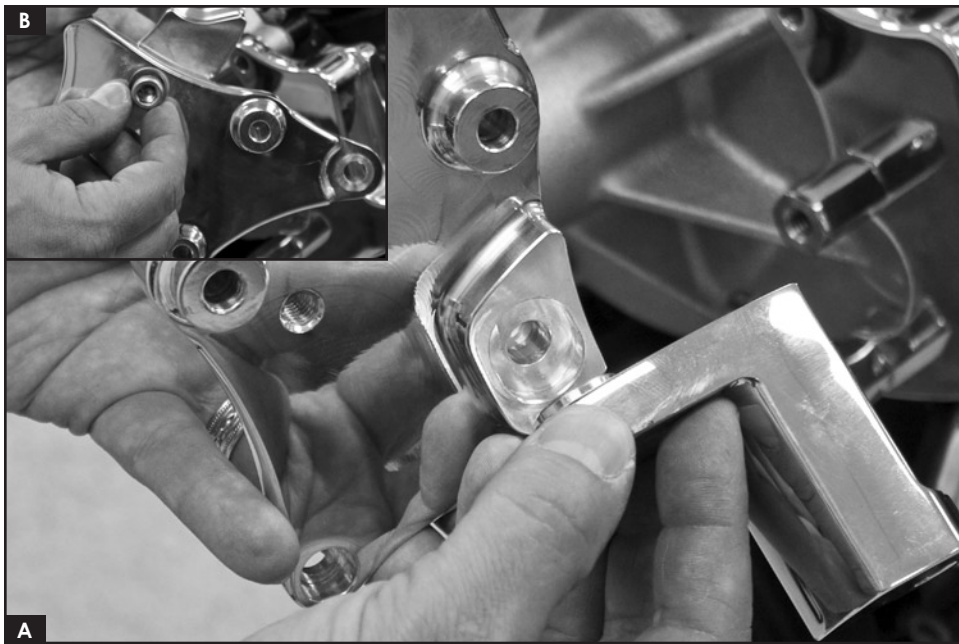
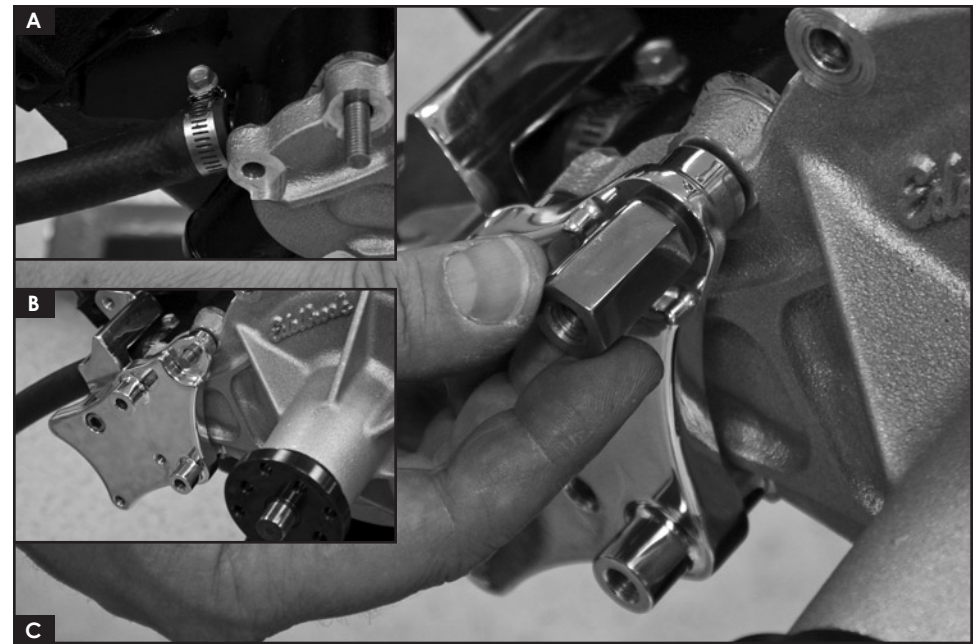

**Figure 5: Assemble Tensioner Bracket**

Apply anti-seize to the treads of the 3/8-16 x 1" socket head cap screw.

**[A]** Attach AC bracket to the back of the tensioner bracket as shown. Make sure key is fully inserted into bracket.

**[B]** Thread cap screw through tensioner bracket and into AC bracket, tighten firmly.

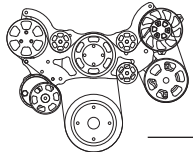

**Figure 6: Install Tensioner Bracket Assembly**

**[A]** Now is a good time to install the heater hose and clamp.

**[B]** Place tensioner / AC bracket assembly on passenger side of motor as shown.

**[C]** Thread one 1-1/16" tall standoff onto the top 3/8" stud and finger tighten.



**Billet Specialties**

**TRU Trac**



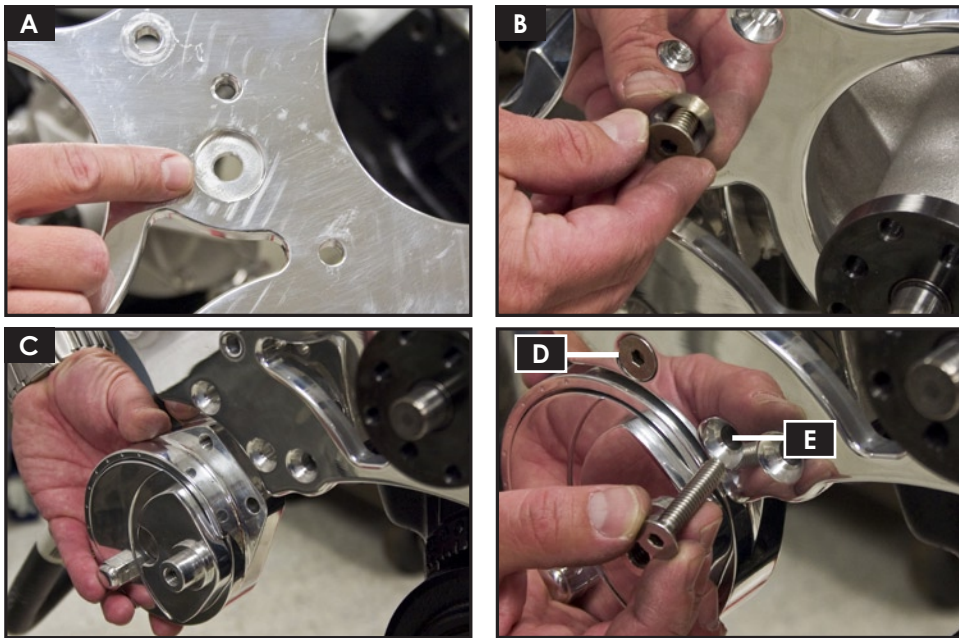

**Figure 7: Install Bridge Bracket**

Apply anti-seize to two 3/8-16 x 3/4" flat head cap screws.

**[A]** Locate recess on the back of the bridge bracket on the left and right sides. Each recess fits over the top spacer nuts.

**[B]** Thread one of the 3/8-16 x 3/4" flat head cap screws through the bridge bracket and into the spacer nut on the passenger side, finger tighten. Thread the other 3/8-16 x 3/4" flat head cap screws through the bridge bracket and into the top spacer nut on the driver side, finger tighten.

Apply anti-seize to the 5/16-18 x 1" & 5/16-18 x 1-1/2" flat head cap screws and 5/16-18 x 3/4" socket head head cap screw.

**[C]** Slide tensioner in between bridge bracket and tensioner bracket.

**[D]** Thread the 5/16-18 x 1" flat head cap screw through the upper hole of the tensioner, finger tighten.

**[E]** Thread the 5/16-18 X 1-1/2" flat head cap screw through the lower hole of the tensioner, finger tighten.

**[F]** Finalize by threading the 5/16-18 x 3/4" socket head cap screw through the back of the tensioner bracket and into the tensioner, tighten this fastener firmly.

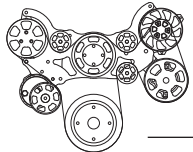

**Billet Specialties**

**TRU Trac**

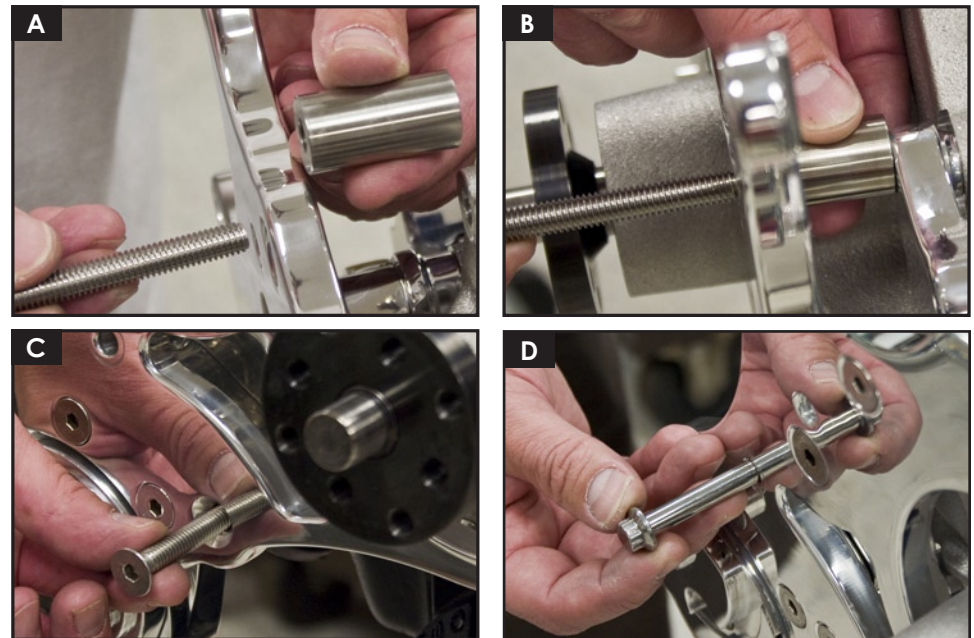

**Figure 8: Complete Bridge Bracket Install**

Apply anti-seize to the following:  
 (3) 5/16-18 x 3" flat head cap screws  
 (1) 5/16-18 x 3" 12pt. cap screw

**[A]** Install the first 5/16-18 x 3" flat head cap screw on the passenger side by placing the 1-15/32" long spacer between the bridge bracket and water pump, then threading the fastener through the bridge bracket, spacer and water pump; finger tighten.

**[B]** Install the next 5/16-18 x 3" flat head cap screw on the driver side by placing the 15/16" spacer between the bridge bracket and water pump, then threading the fastener through the bridge bracket, spacer, alternator bracket and water pump; finger tighten.

**[C]** Install the final 5/16-18 x 3" flat head cap screw near tensioner assembly by threading through the bridge bracket, tensioner bracket and water pump, finger tighten.

**[D]** Next thread the 5/16-18 x 3" 12pt. cap screw through the bridge bracket just above the tensioner as shown and finger tighten

**NOTE:** At this time tighten the left side spacer nut followed by all the bridge bracket fasteners.



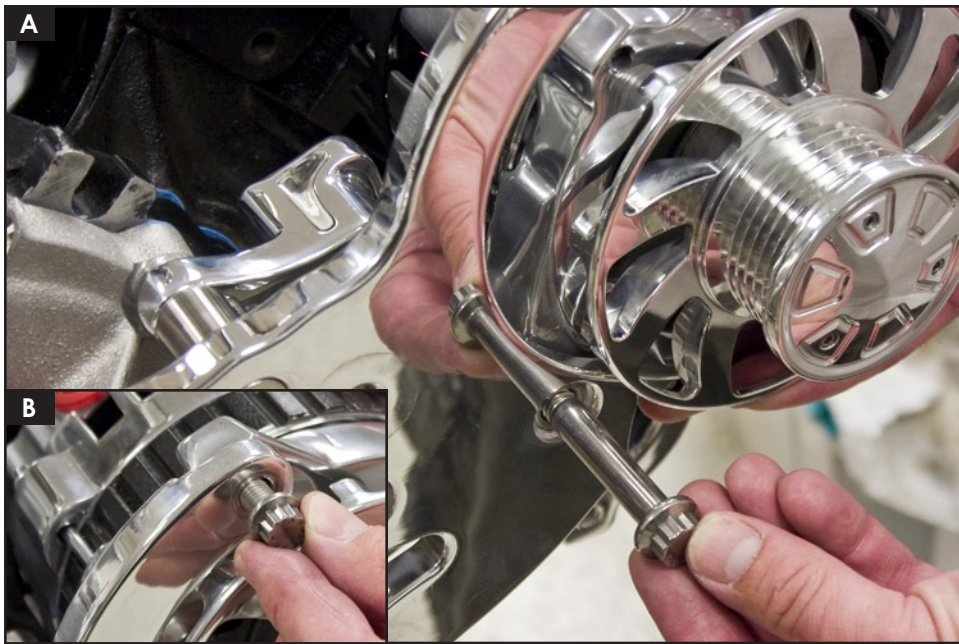

**Figure 9: Install Alternator**

Apply anti-seize to the following:

- (1) 8mm-1.25 x 25mm 12pt. cap screw
- (1) 10mm-1.5 x 70mm 12pt. cap screw

**[A]** Place alternator between the alternator bracket and the bridge bracket, align bottom holes. Thread the 10mm-1.5 x 70mm 12pt. cap screw through bridge bracket, alternator and into alternator bracket, finger tighten.

**[B]** Rotate alternator up to align the top alternator boss with the top bridge bracket ear. Thread the 8mm 12pt. cap screw through the bridge bracket and into alternator.

Firmly tighten both fasteners.

**NOTE:** The alternator boss may vary in width due to the polishing process. Check lower alternator mount boss to see if shims are needed. Included with this kit are .5 & 1mm shim washers, these shims may or may not be needed.

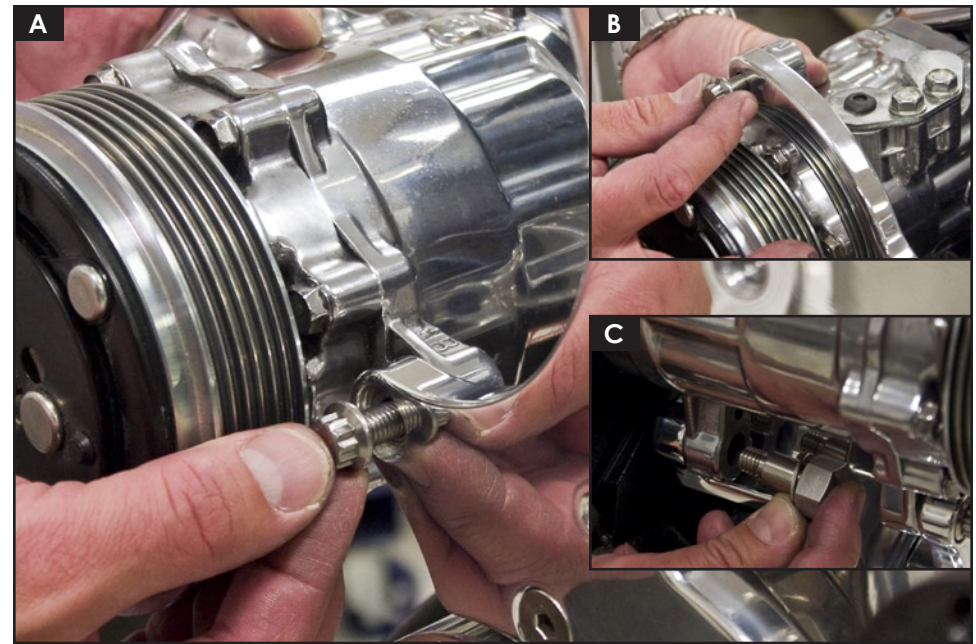

**Figure 10: Install AC Compressor**

Apply anti-seize to the following:

- (1) Compressor shoulder bolt
- (2) 8mm-1.25 x 25 12pt. cap screws

**[A]** Place air compressor between the bridge bracket and the tensioner bracket. Thread one of the 8mm-1.25 x 25mm 12pt. cap screws through the bridge bracket and into the bottom boss of the compressor.

**[B]** Thread the second 8mm-1.25 x 25mm 12pt. cap screw through the bridge bracket and the top boss of the compressor.

**[C]** Finish by installing the compressor shoulder bolt through the bottom rear boss of the compressor and into the compressor bracket.

**\* AT THIS TIME TIGHTEN ALL FASTENERS FIRMLY \***

**Figure 9: Install AC Compressor Cover**

Apply Loctite Blue 242 to the following:

- (3) 1/4-20 x 3/4" socket head cap screws

**[A]** Place cover on clutch and thread the socket head cap screws through the cover and into the clutch, torque to 40-45 inch/lbs.

Caution: Over tightening these fasteners will cause damage to the compressor clutch.  
**Do Not Over Tighten.**

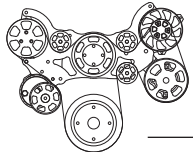



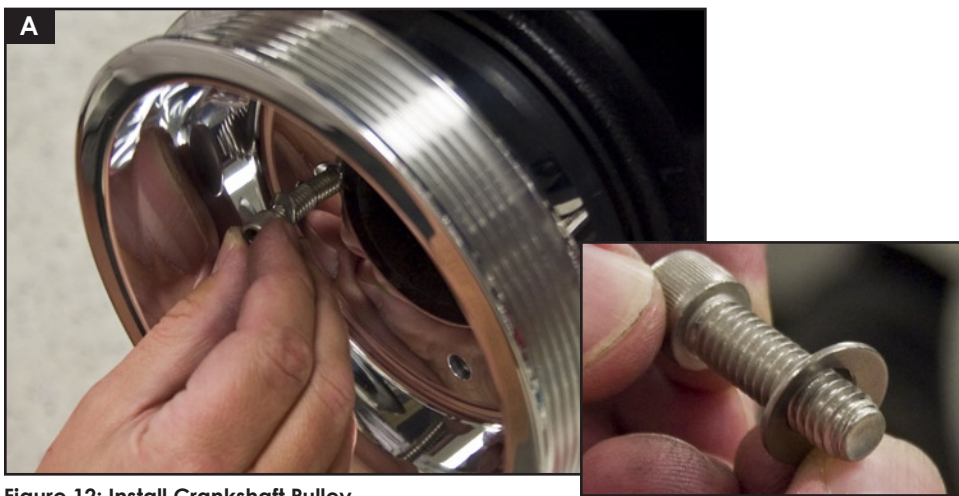

**Figure 11: Install Power Steering Pump & Pulley**

For kits without power steering continue to Figure 11.

Apply anti-seize to the two 5/16-18 x 2-3/4" socket head cap screws.

**[A]** Place power steering pump to bracket and thread the two 5/16-18 x 2-3/4" socket head cap screws with 5/16" split washers through the power steering pump bosses and into the power steering bracket and tighten firmly (26 ft/lbs).



**Figure 12: Install Crankshaft Pulley**

Apply anti-seize to the four 5/16-18 x 1" socket head cap screws.

**[A]** Place the crank pulley on the damper, thread the four 5/16-18 x 1" socket head cap screws with bellville washers (cup facing pulley) through pulley and into damper, tighten firmly (46ft/lbs).



**Figure 13: Install Water Pump Pulley**

Apply anti-seize to the four 5/16-24 X 3/4" socket head cap screws.

**[A]** Place water pump pulley on water pump shaft, thread the four 5/16-24 X 3/4" socket head cap screws through the nose cone, pulley and into the water pump flange, tighten firmly (28 ft/lbs).

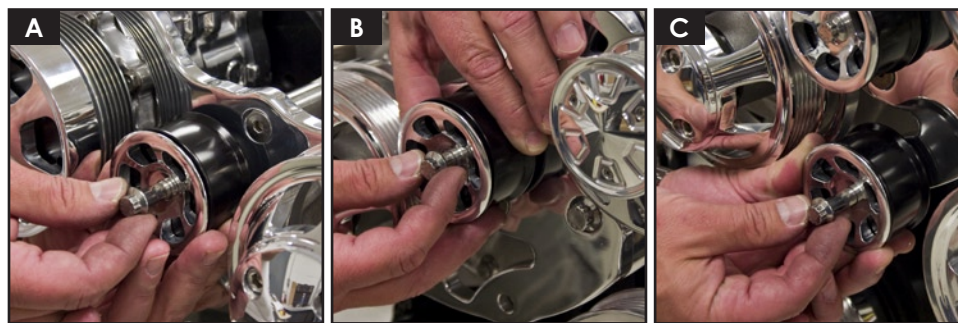

**Figure 14: Install Idler Pulleys**

Apply anti-seize to the following:  
 (2) 3/8-16 x 1-3/4" 12pt. cap screws  
 (1) 3/8-16 x 2" 12pt. cap screw

**[A]** Install the first pulley by threading the 3/8-16 x 1-3/4" 12pt. cap screw through the pulley cover, pulley and boss into the bridge bracket as shown; tighten firmly (46 ft/lbs).

**[B]** Install the next pulley by threading the 3/8-16 x 1-3/4" 12pt. cap screw through the pulley cover, pulley and boss into the bridge bracket as shown; tighten firmly (46 ft/lbs).

**[C]** Finish by installing the lower right driver side pulley using the 3/8-16 x 2" 12pt. cap screw in location as shown.

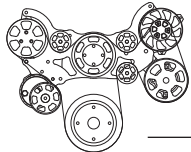

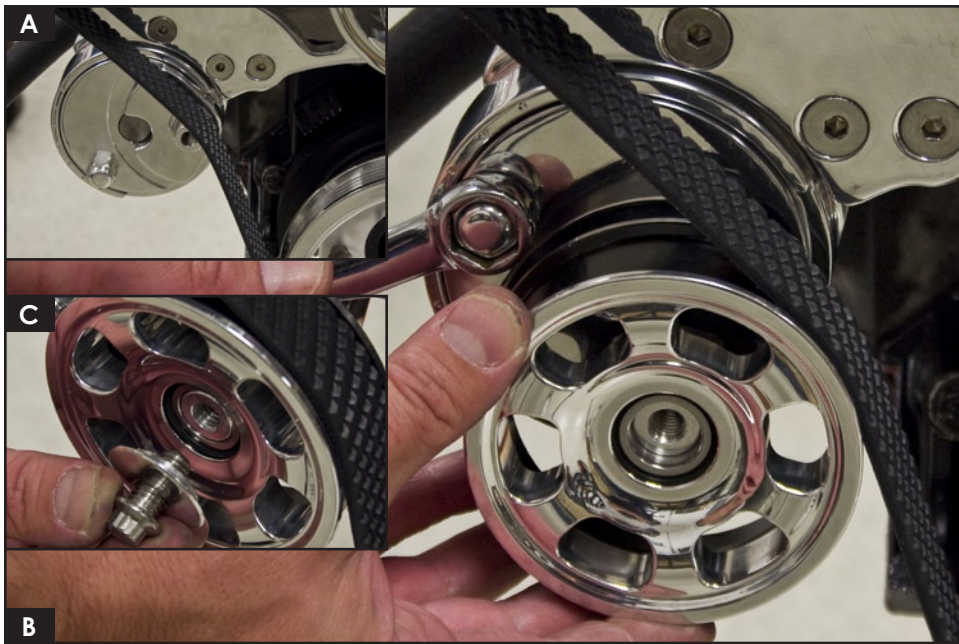

**Figure 15: Install Serpentine Belt & Tensioner Pulley**

Apply anti-seize to the 3/8-16 x 3/4" 12pt. cap screw.

[A] Route serpentine belt as shown below, minus tensioner.

[B] Place a 5/8" box end wrench on tensioner. Align belt onto pulley and pull up until tensioner pulley slips onto tensioner shaft.

Slowly return wrench to starting position to apply tension to belt.

[C] Install the 3/8-16 x 3/4" 12pt. bolt with aluminum washer and tighten firmly. (46 ft/lbs)

**WITH POWER STEERING**

**WITHOUT POWER STEERING**

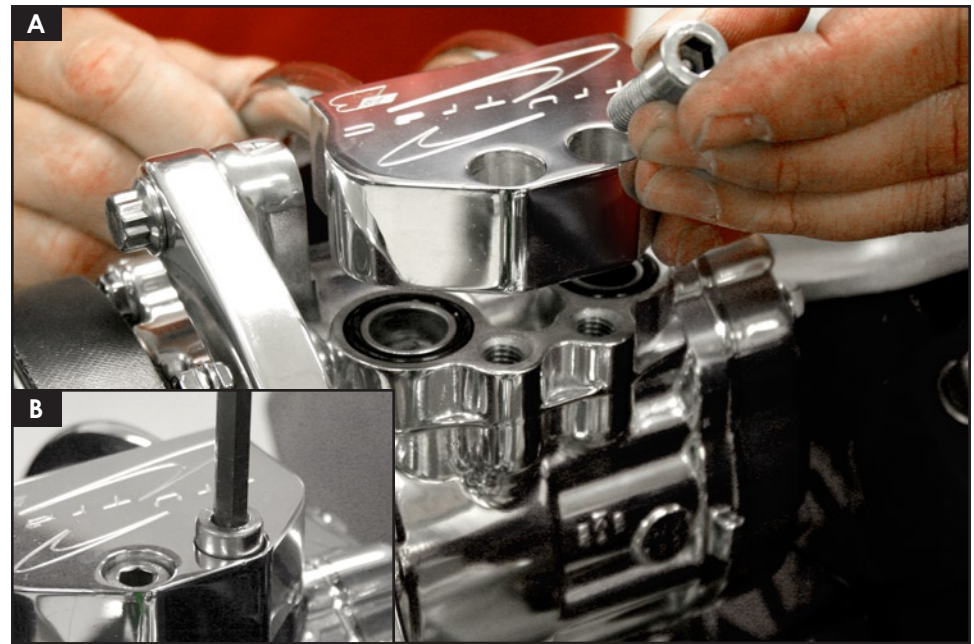
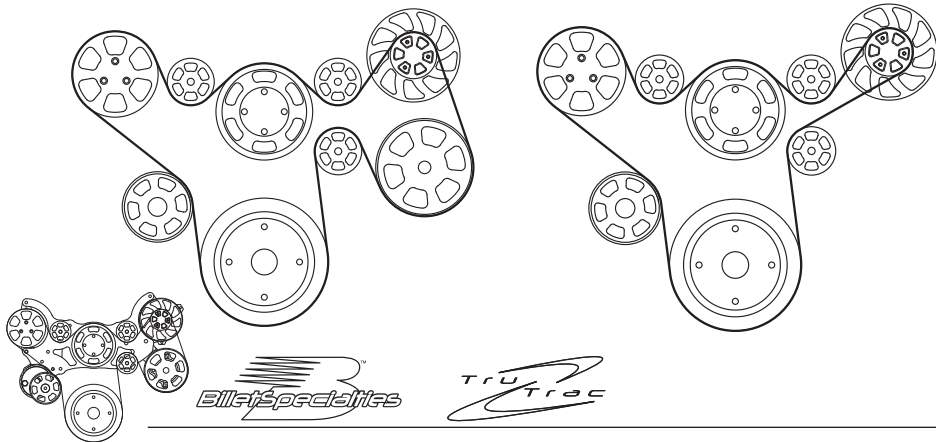

**Figure 16: Install Compressor Manifold**

If you are going to be installing your air conditioning hoses and charging the system at this time, remove the plate on top of the compressor body and apply anti-seize to the two 8mm-1.25 x 25mm socket head cap screws.

**[A,B]** Install compressor manifold onto compressor with two 8mm-1.25 x 25mm socket head cap screws and tighten firmly (13ft/lbs).

Install hoses, connect clutch wire and charge system.

If you are **NOT** installing hoses and charging the system at this time, place compressor manifold and hardware in a safe place and leave cover plate on compressor at this time.

**Do not connect clutch wire or apply power to clutch wire without the hoses connected and system charged – Serious damage will occur to compressor.**

**Compressor Oil**

Although the compressor is supplied with oil, the level may not be correct for the entire system. Consult the instruction manual of the air conditioning unit for proper levels and system charging procedures.



Billet Specialties, Inc.  
500 Shawmut Ave.  
La Grange, IL 60526  
Tech Line 708/588-0505  
Fax 708/588-7181  
billetspecialties.com