

Tru Trac™

Ford FE
Installation Manual
For Systems with A/C
#14700 / #14720

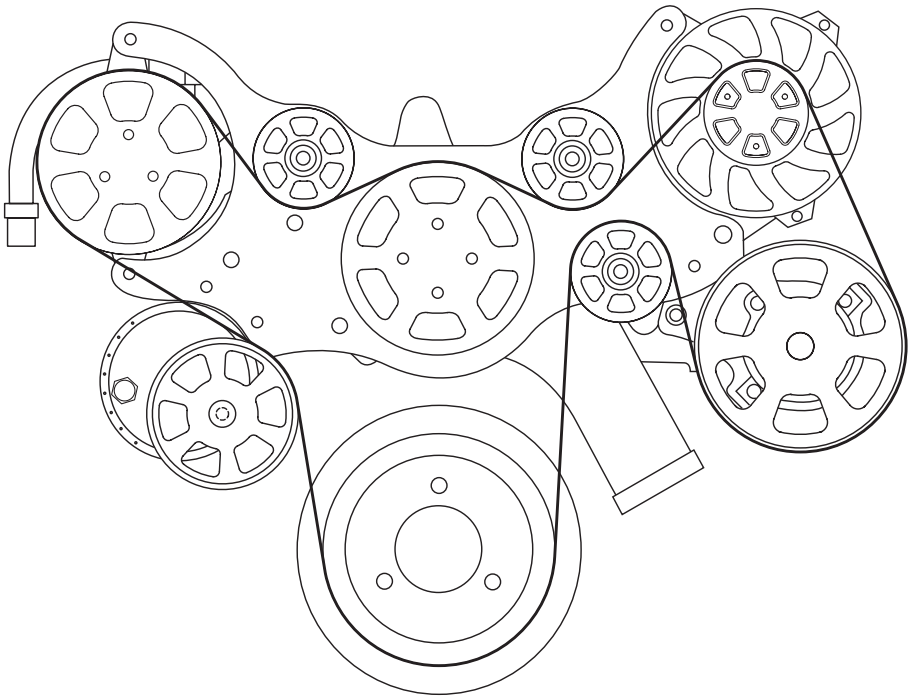

Billet Specialties, Inc.
500 Shawmut Avenue.
La Grange, Illinois 60526
Tech Line (708) 588-0505
Fax (708) 588-7181

PLEASE READ ALL INSTRUCTIONS BEFORE INSTALLING ANY COMPONENTS OF THE TRU TRAC SERPENTINE SYSTEM

Tech Line: 708.588.0505
Fax: 708.588.7181
www.billetpecialties.com

Required Tools & Materials

- | | | |
|--|--|--------------------------------------|
| <input type="checkbox"/> Anti-seize Compound | <input type="checkbox"/> 5/8" Box End Wrench | <input type="checkbox"/> 3/16" Allen |
| <input type="checkbox"/> RTV Silicone | <input type="checkbox"/> 3/4" Box End Wrench | <input type="checkbox"/> 5/16" Allen |
| <input type="checkbox"/> Permatex Hylomar® gasket dressing | <input type="checkbox"/> 9/16" Box End Wrench | <input type="checkbox"/> 1/4" Allen |
| <input type="checkbox"/> Gasket Scraper | <input type="checkbox"/> Socket Wrench & Extension | <input type="checkbox"/> 7/32" Allen |
| <input type="checkbox"/> Scotch-Brite® Pad | <input type="checkbox"/> 10mm 12pt. socket | <input type="checkbox"/> 6mm Allen |
| <input type="checkbox"/> 3/8-16 Thread Chaser* & Holder | <input type="checkbox"/> 12mm 12pt. socket | |
- *Thread chasers are available at your local parts store and are different from a thread cutting tap.

TECH TIP:

Billet Specialties recommends the use of Anti-Seize on all fasteners to prevent thread lock-up.

Skin Board #1 - Packaged with Power Steering Pump

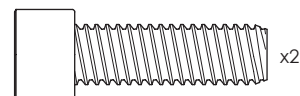

5/16-18 x 1" Socket Head Cap Screw
Power Steering Bracket To Timing Cover



5/16-18 x 2-3/4" Socket Head Cap Screw
Power Steering Pump To Bracket

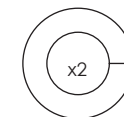

5/16"
Lock Washer

Skin Board #3 - Packaged In Main Box

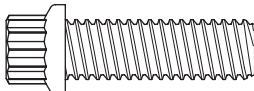
 x3
 8mm-1.25 x 25mm 12pt. Cap Screw
 Bridge Bracket To Alternator & Compressor

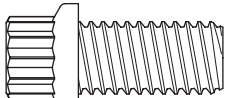
 x1
 3/8-16 x 3/4" 12pt. Cap Screw
 Tensioner Pulley

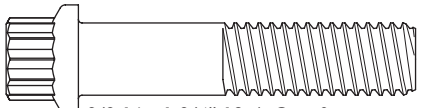
 x3
 3/8-16 x 1-3/4" 12pt. Cap Screw
 Idler Pulleys

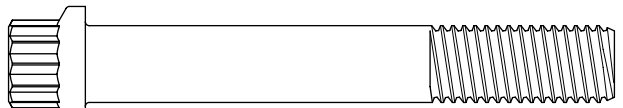
 x1
 10mm-1.5 x 70mm 12pt. Cap Screw
 Bridge Bracket To Alternator

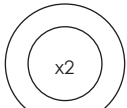
 x2
 10mm x .5mm Shim Washer

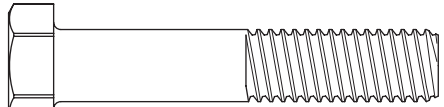
 x1
 3/8-16 x 2" Hex Head Cap Screw
 Backside Of Alternator Bracket

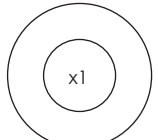
 x1
 3/8" Flat Washer

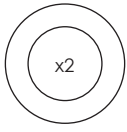
 x2
 10mm x 1mm Shim Washer

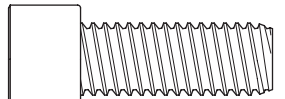
 x1
 3/8-16 x 1" Socket Head Cap Screw
 Alternator & Compressor Brackets

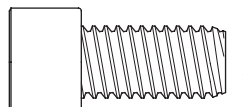
 x1
 3/8-16 x 3/4" Socket Head Cap Screw
 Alternator & Compressor Brackets

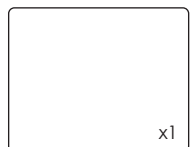
 x1
 13/16" Spacer

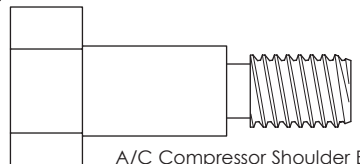
 x1
 A/C Compressor Shoulder Bolt

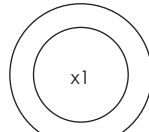
 x1
 1/2" Flat Washer

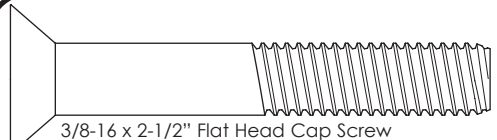
 x1
 3/8-16 x 2-1/2" Flat Head Cap Screw
 Thru Bridge Bracket To Tensioner Bracket

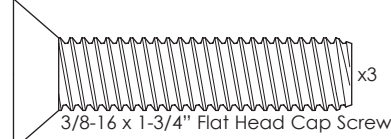
 x3
 3/8-16 x 1-3/4" Flat Head Cap Screw
 Bridge Bracket To Water Pump

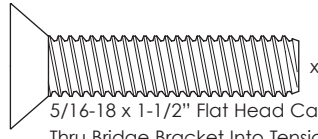
 x1
 5/16-18 x 1-1/2" Flat Head Cap Screw
 Thru Bridge Bracket Into Tensioner

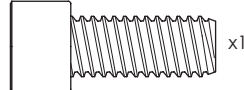
 x1
 5/16-18 x 3/4" Socket Head Cap Screw
 Into Backside Of Tensioner Thru Tensioner Bracket

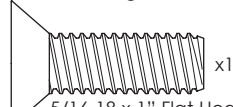
 x1
 5/16-18 x 1" Flat Head Cap Screw
 Thru Bridge Bracket Into Tensioner

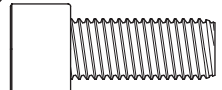
 x4
 5/16-24 x 3/4" Socket Head Cap Screw
 Water Pump Pulley

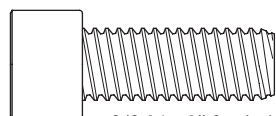
 x3
 3/8-16 x 1" Socket Head Cap Screw
 Crankshaft Pulley

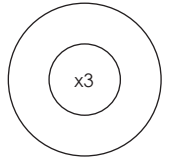
 x3
 3/8" Belleville Washer

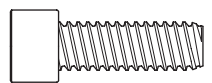
 x3
 1/4-20 x 3/4" Socket Head Cap Screw
 A/C Clutch Cover

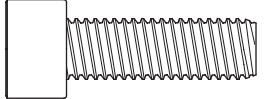
 x2
 8mm-1.25 x 25mm Socket Head Cap Screw
 A/C Compressor Manifold

Other Hardware / Gaskets

- Goodyear Poly-V Serpentine Belt - 72.50" #4060725 (with power steering)
- Goodyear Poly-V Serpentine Belt - 60.00" #4060600 (without power steering)

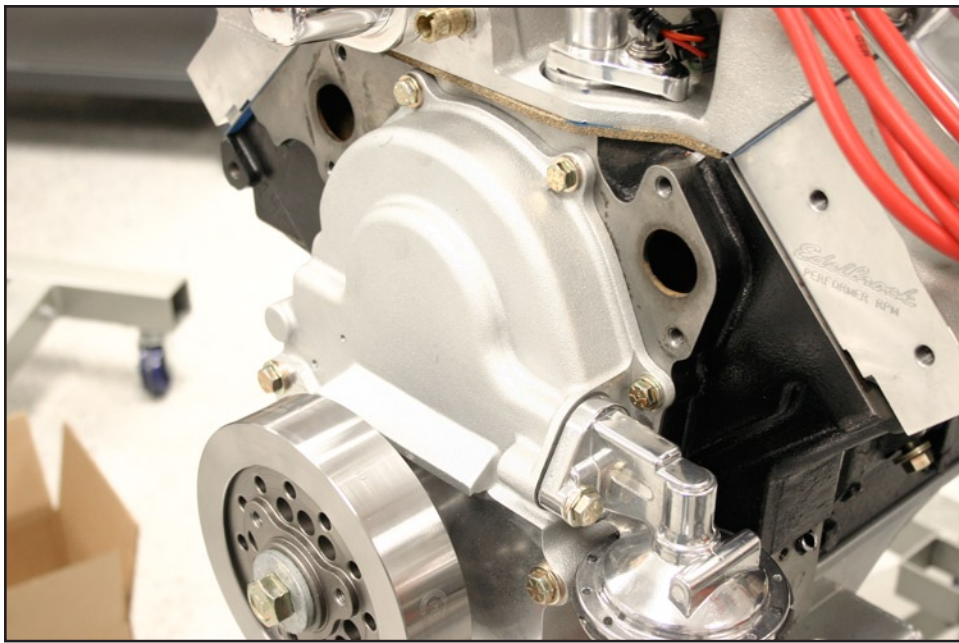

FIGURE 1: Prepping The Block

Disconnect battery; remove all existing accessory drive brackets and components from motor.

Remove water pump, scrape away any existing gasket material with a gasket scraper and dress surface with a Scotch Brite® pad.

Clean and prep water pump threads on engine block, use a 3/8-16 thread chaser if necessary. Thread chasers are available at your local auto parts store or tool dealer and are different from a thread cutting tool.

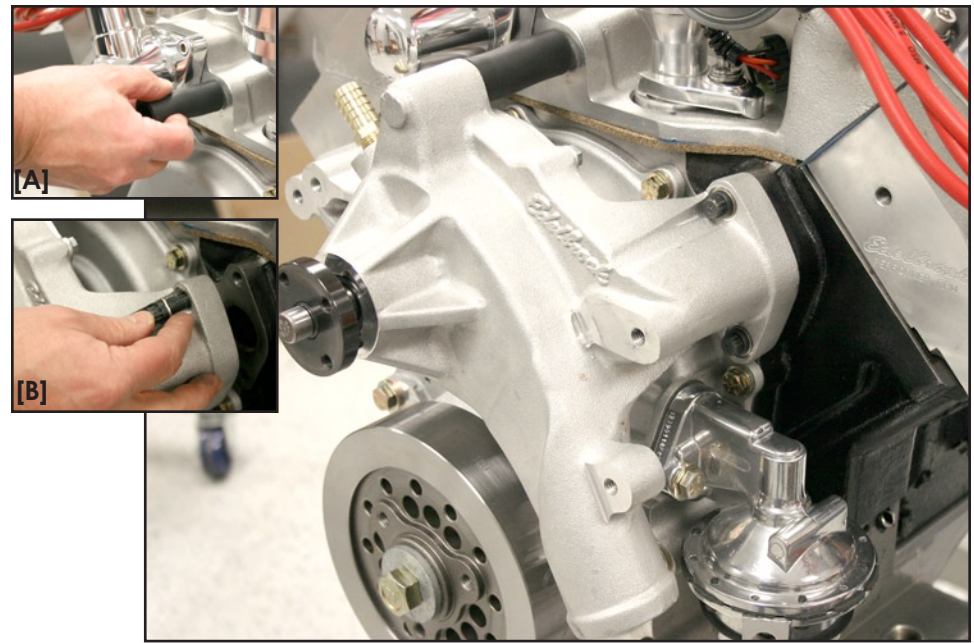

FIGURE 2: Install Water Pump

Install brass heater fitting (or plug) and bypass fitting into water pump (included with pump).

Apply RTV sealer to bolts provided with water pump. Coat both sides of water pump gasket with Permatex Hylomar® gasket dressing.

[A] Install bypass hose from manifold to water pump.

[B] Install water pump to engine block with hardware included with pump. Tighten to OE specs.

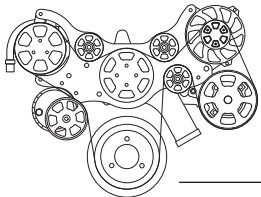

TRU
Trac

Billet Specialties

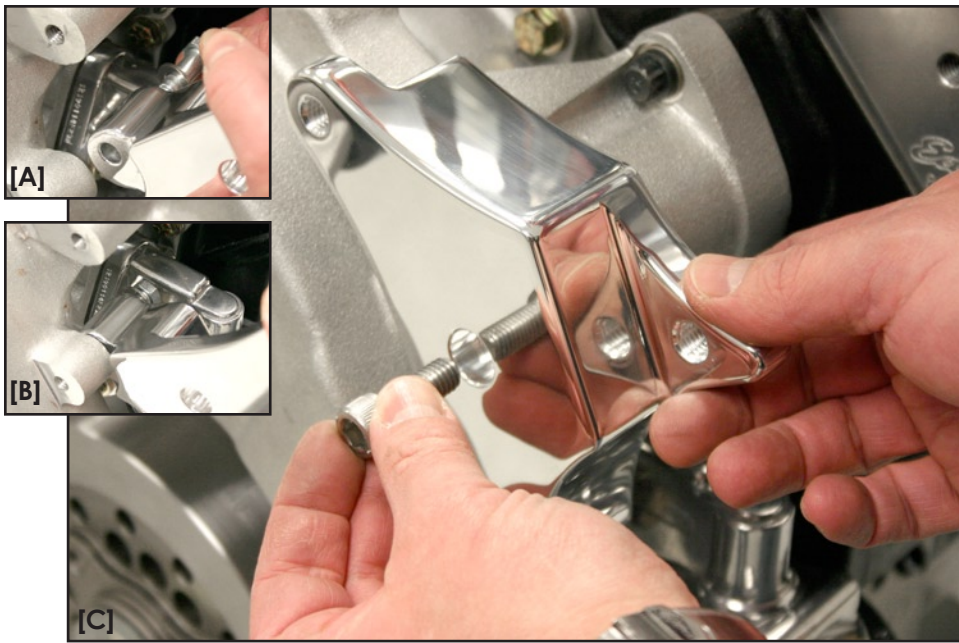

FIGURE 3: Install Alternator Bracket To Water Pump

Apply anti seize to one 3/8-16 x 2" hex head cap screw and one 3/8-16 x 3/4" socket head cap screw.

[A,B] Place alternator bracket on driver side of water pump as shown. Thread the 3/8-16 x 2" hex head cap screw with a 3/8" washer through the back of the bracket and into the water pump, finger tighten.

[C] Swing bracket into position by aligning the front bracket mount hole with the water pump boss. Insert 3/8-16 x 3/4" socket head cap screw through bracket and into water pump boss. Tighten both fasteners firmly at this time. (46ft/lbs.)

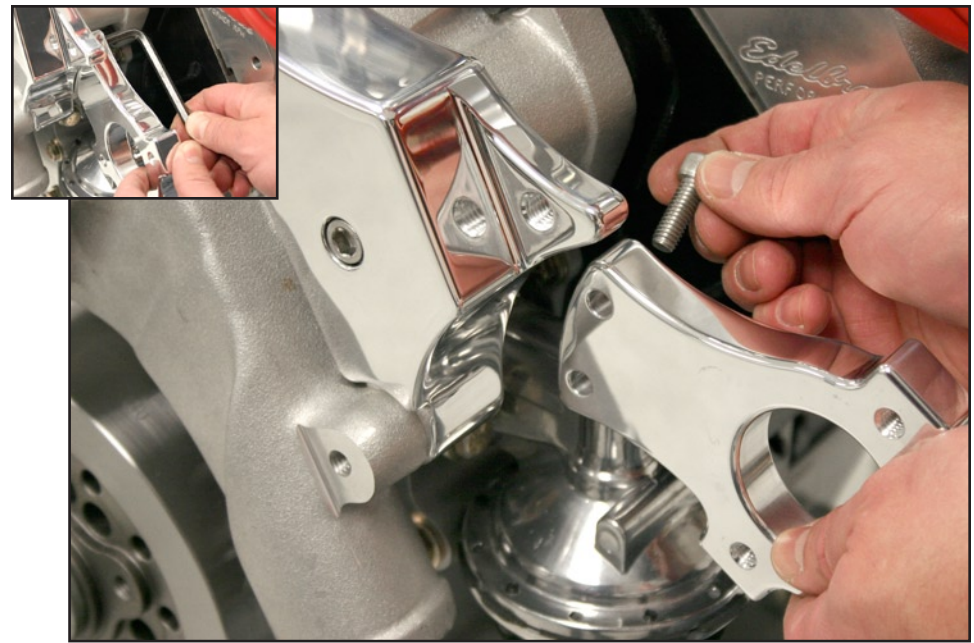
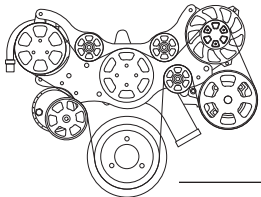

FIGURE 4: Install Power Steering Pump Bracket

For kits without power steering continue to Figure 5.

Apply anti seize to two 5/16-18 x 1" socket head cap screws.

Place power steering bracket behind alternator bracket as shown above, thread the 5/16-18 x 1" socket head cap screws through the power steering bracket and into the alternator bracket, tighten firmly (26ft/lb).



TRU
Trac

BilletSpecialties



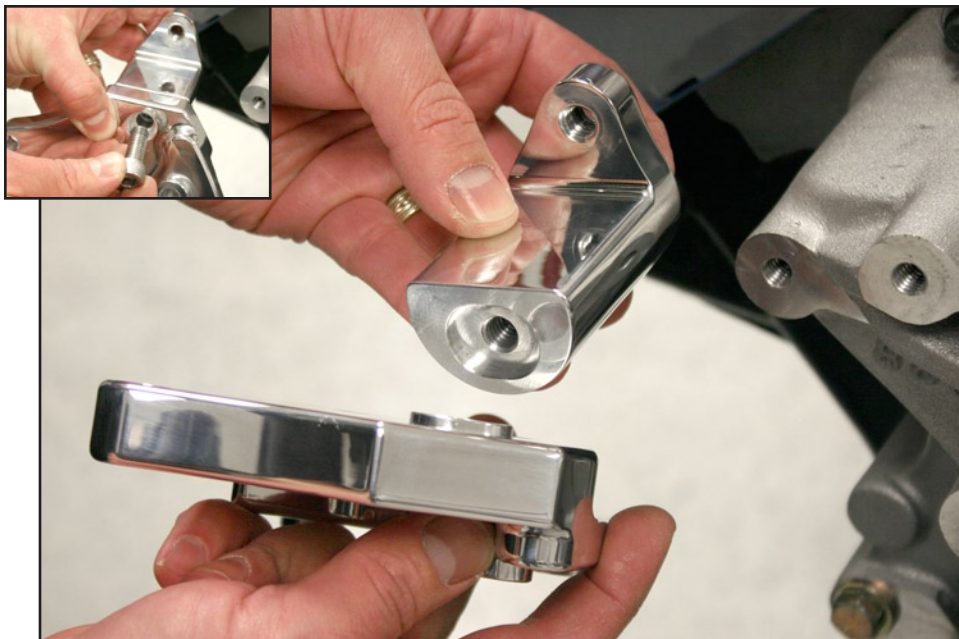

FIGURE 5: Install Compressor Bracket

Apply anti seize to one 3/8-16 x 1" socket head cap screw.

Place compressor bracket onto tensioner bracket as shown, locking boss into recess on bracket.

Thread the 3/8-16 x 1" socket head cap screw through the compressor bracket into the tensioner bracket and tighten firmly (46 ft/lbs).

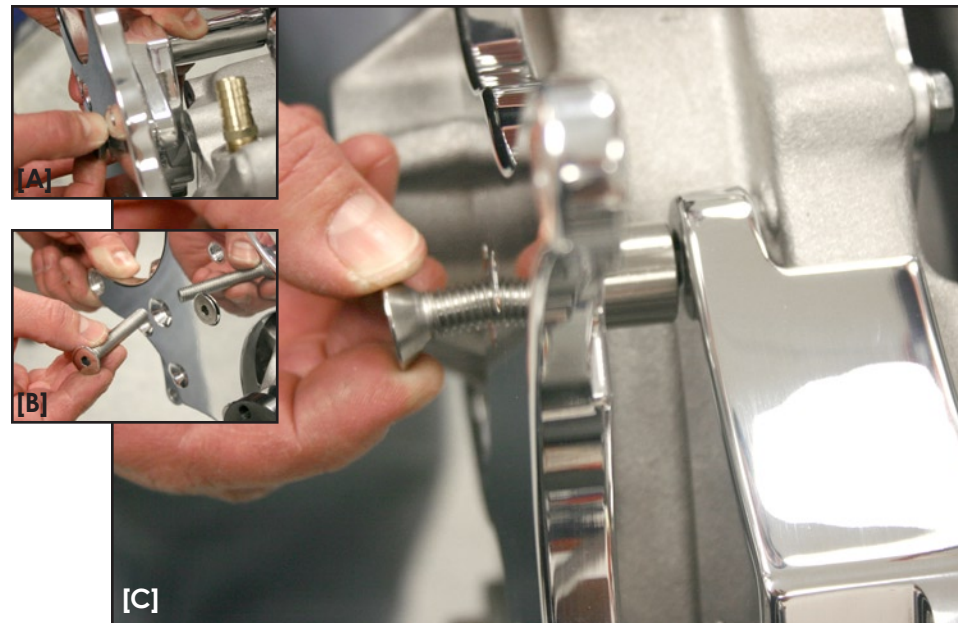
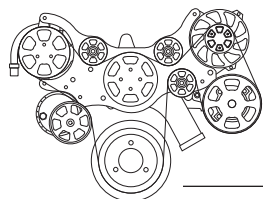
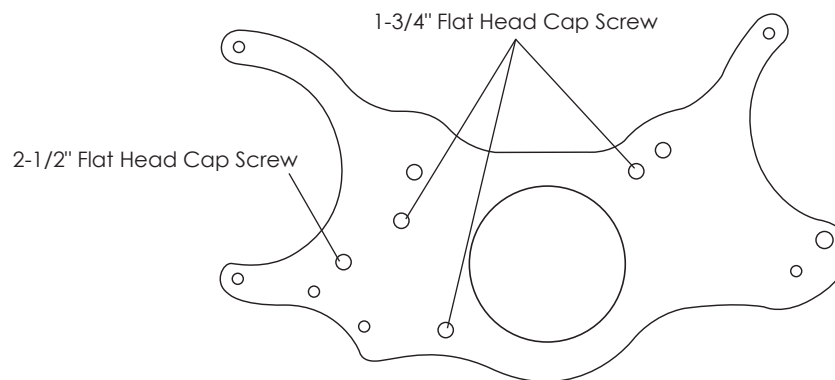

FIGURE 6: Install Tensioner Bracket Assembly & Bridge Bracket

Apply anti seize to three 3/8-16 x 1-3/4" flat head cap screws and one 3/8-16 x 2-1/2" flat head cap screw.

[A] On the passenger side, thread two 3/8-16 x 1-3/4" flat head cap screws through the bridge bracket and tensioner bracket as shown; aligning with bosses on water pump and finger tighten. [B] Thread the 3/8-16 x 2-1/2" flat head cap screw through the bridge bracket, see location below.

[C] On the driver side, thread the remaining 3/8-16 x 1-3/4" flat head cap screw through the top hole in the bridge bracket and through the 13/16" spacer and into the water pump boss as shown, and finger tighten.



TRU
Trac

Billet Specialties



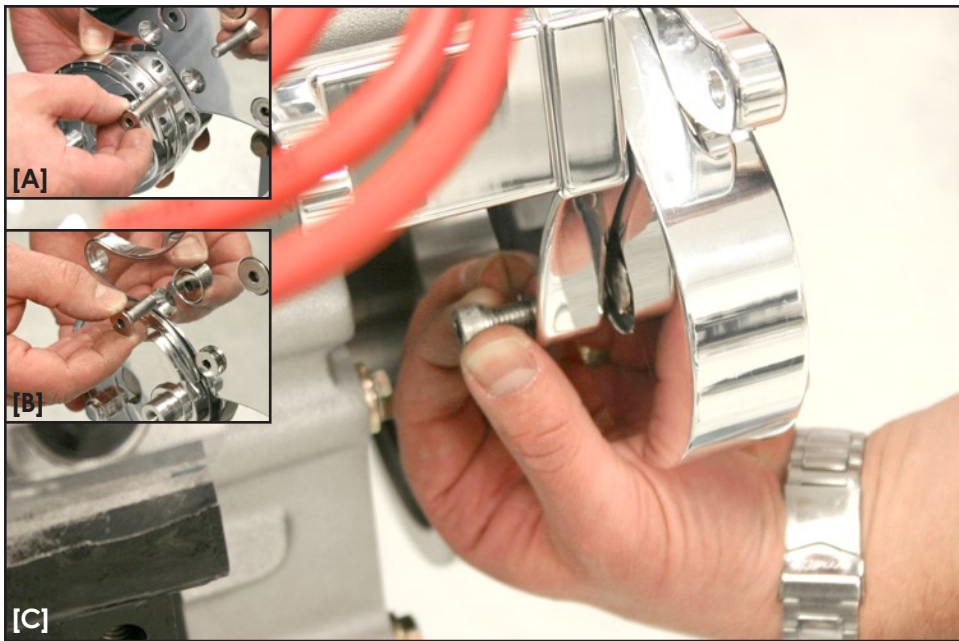

FIGURE 7: Install Tensioner

Apply anti seize to one 5/16-18 x 1" flat head cap screw, one 5/16-18 x 1-1/2" flat head cap screw, and one 5/16-18 x 3/4" socket head cap screw.

[A,B] Place tensioner between bridge bracket and tensioner bracket; thread the 1-1/2" long flat head cap screw through the right tensioner hole and the 1" long flat head cap screw through the left hole and finger tighten.

[C] Finish installation by threading the 5/16-18 x 3/4" socket head cap screw through the tensioner bracket and into the tensioner as shown and tighten firmly.

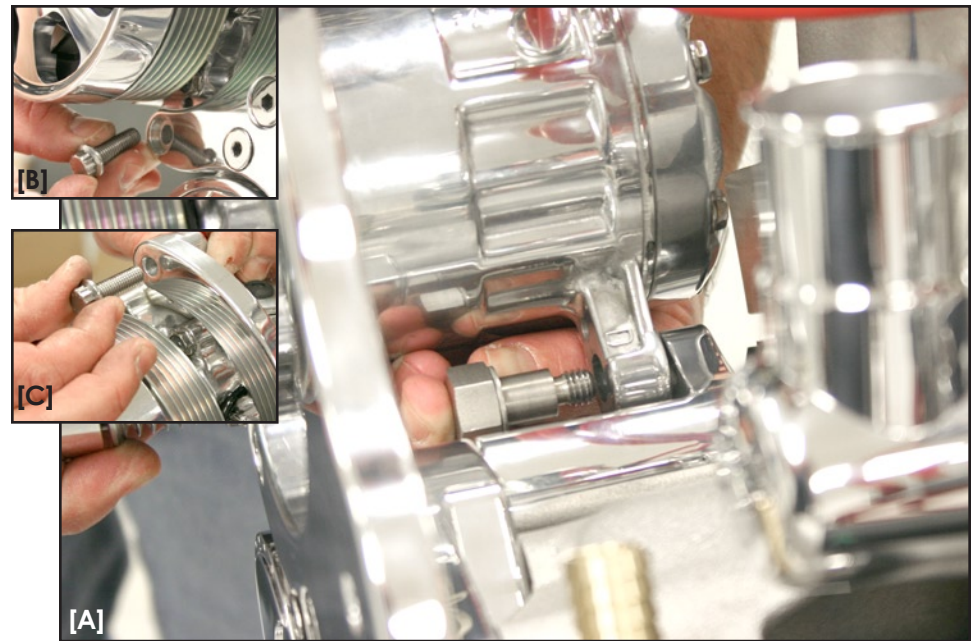

FIGURE 8: Install A/C Compressor

Apply anti seize to the compressor shoulder bolt and two 8mm-1.25 x 25mm 12pt ARP cap screws.

[A] Place A/C compressor between the compressor bracket and bridge bracket, thread compressor shoulder bolt with flat washer through compressor boss and into compressor bracket as shown and finger tighten while supporting compressor.

[B] Thread one 8mm-1.25 x 25mm 12pt ARP cap screw through lower bridge bracket hole and into compressor lower boss, finger tighten.

[C] Finish compressor installation by threading final 8mm-1.25 x 25mm 12pt ARP cap screw through upper bridge bracket and into top compressor boss, finger tighten.

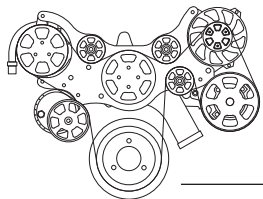

TRU
Trac

Billet Specialties

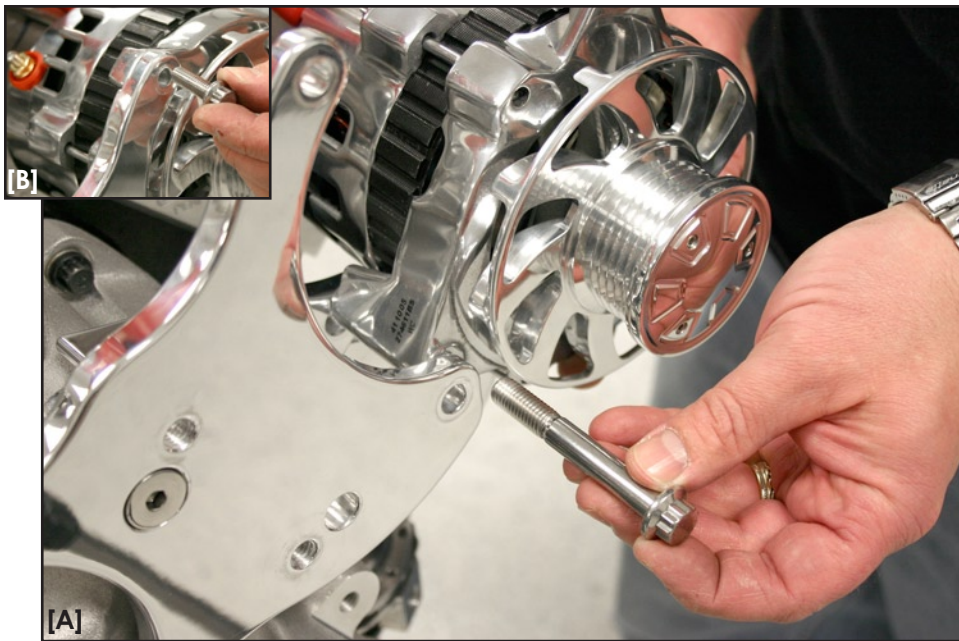

FIGURE 9: Install Alternator

Apply anti seize to one 10mm-1.5 x 70mm 12pt ARP cap screw and one 8mm-1.25 x 25mm 12pt ARP cap screw.

[A] Place alternator between the alternator bracket and bridge bracket aligning the bottom bridge bracket hole with the lower alternator boss. Thread the 10mm-1.5 x 70mm 12pt ARP cap screw through the bridge bracket, alternator and into the alternator bracket.

[B] Finish alternator installation by threading the 8mm-1.25 x 25mm 12pt ARP cap screw through the bridge bracket and into the top alternator boss.

TIGHTEN ALL FASTENERS AT THIS TIME including compressor bolt and rear tensioner bolt. Leave lower alternator bolt loose and check to see if a shim needs to be added at this time.

The alternator mounting boss may vary in thickness due to the polishing process. 10mm shim washers are provided to shim alternator to bridge bracket (washers may or may not be needed).

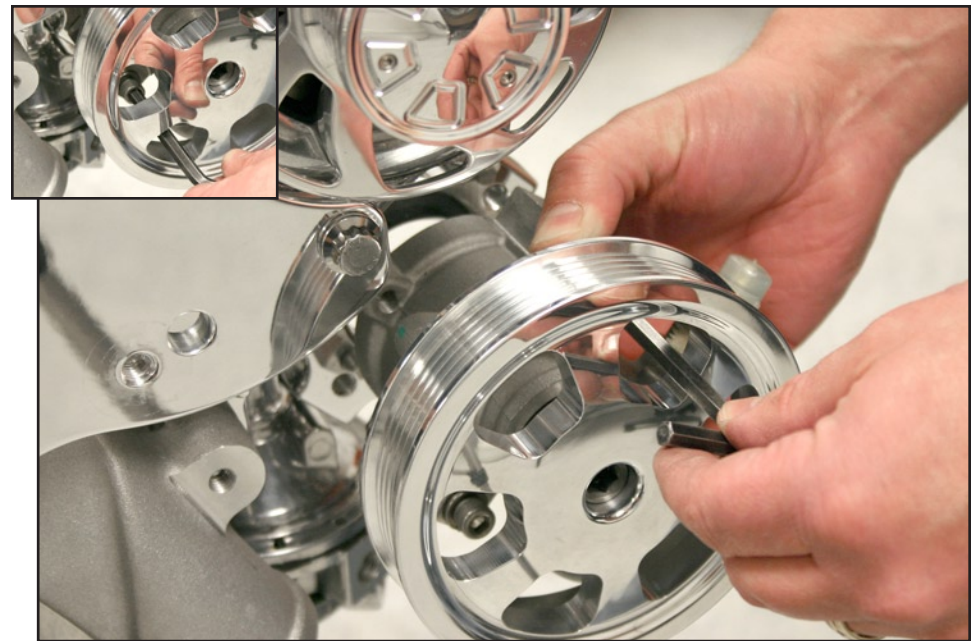
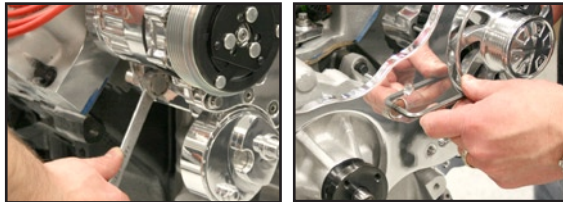
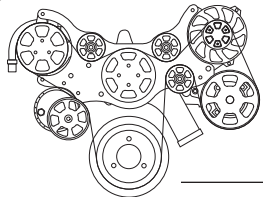

FIGURE 10: Install Power Steering Pump With Pulley

For kits without power steering continue to Figure 11.

Apply anti seize to the two 5/16-18 x 2-3/4" socket head cap screws.

Place power steering pump to bracket and thread the two 5/16-18 x 2-3/4" socket head screws with 5/16" lock washers through the power steering pump bosses and into the power steering bracket and tighten firmly (26 ft/lbs).





[A]



[B]

FIGURE 11: Install Crankshaft & Water Pump Pulleys

Apply anti seize to three 3/8-16 x 1" socket head cap screws and the four 5/16-24 x 3/4" socket head cap screws.

[A] Place the crankshaft pulley on the damper, thread the three 3/8-16 x 1" socket head screws with belleville washers (cup facing pulley) through pulley and into damper, tighten firmly (46ft/lbs).

[B] Finish by placing water pump pulley on water pump shaft, thread the four 5/16-24 x 3/4" socket head cap screws through the pulley and into the water pump flange, tighten firmly (28 ft/lbs).

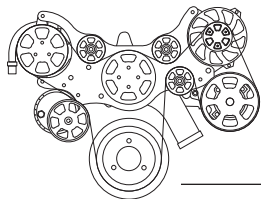

TRU
Trac

BilletSpecialties

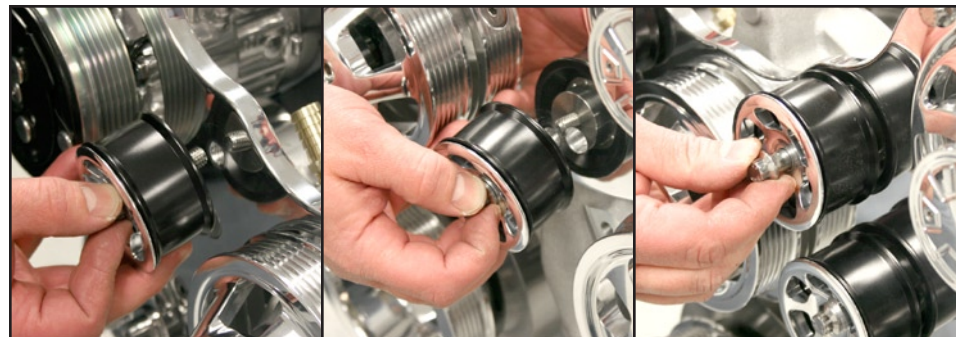

FIGURE 12: Install Idler Pulleys

Apply anti seize to the three 3/8-16 x 1-3/4" 12 pt ARP cap screws.

Install the first pulley by threading the 12 pt ARP cap screw through the pulley cover, pulley and boss into the bridge bracket, tighten firmly (46 ft/lbs). Follow by installing the next two pulleys as shown.

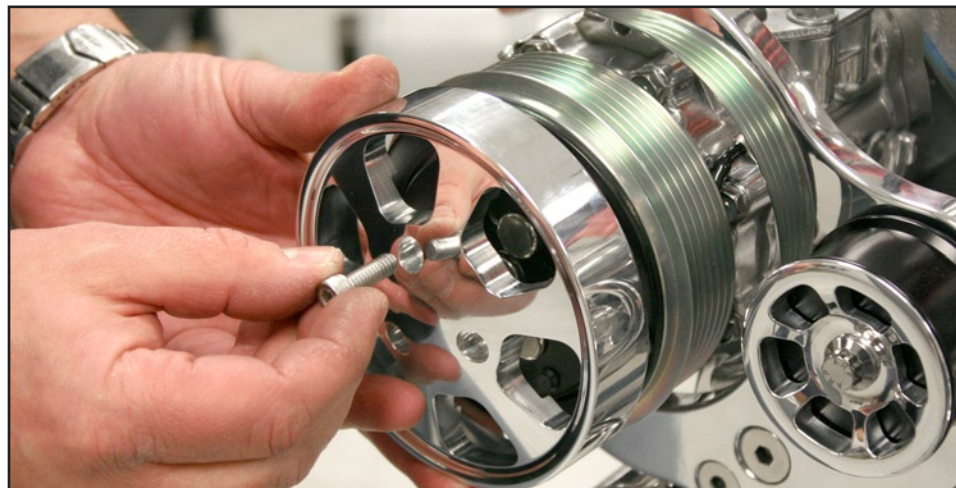

FIGURE 13: Install Compressor Clutch Cover

Apply Loctite Blue 242 to the following:
(3) 1/4-20 x 3/4" socket head cap screws

Place cover on clutch and thread the socket head cap screws through the cover and into the clutch, torque to 40-45 **inch/lbs**.

Caution: Over tightening these fasteners will cause damage to the compressor clutch. **Do Not Over Tighten.**

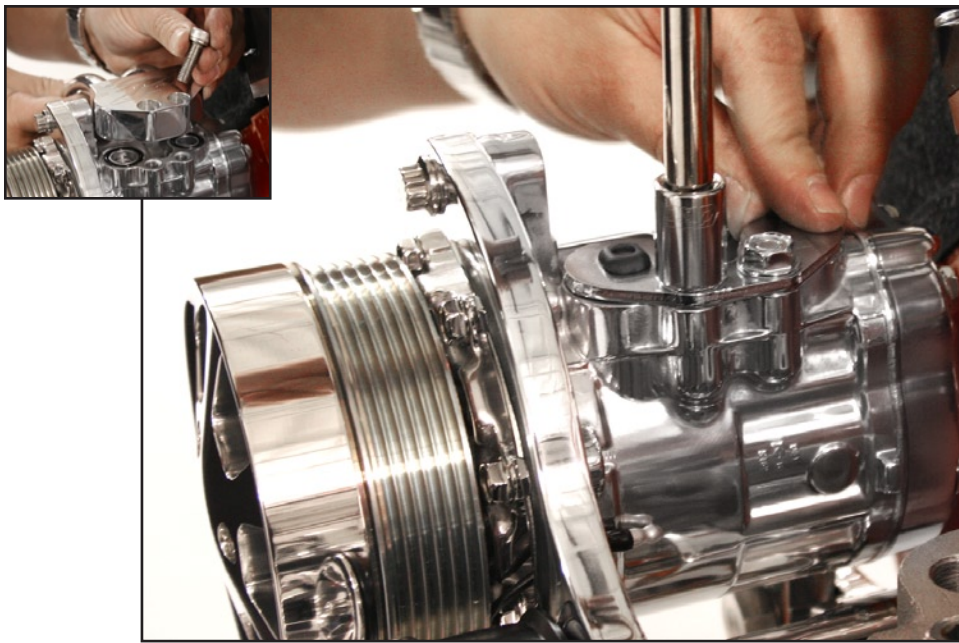

FIGURE 14: Install Compressor Manifold

If you are going to be installing your air conditioning hoses and charging the system at this time, remove the plate on top of the compressor body and apply anti seize to the two 8mm-1.25 x 25mm socket head cap screws.

Install compressor manifold onto compressor with two 8mm-1.25 x 25mm socket head cap screws and tighten firmly (13ft/lbs).

Install hoses; connect clutch wire and charge system.

IMPORTANT

- If you are *NOT* installing hoses and charging the system at this time, place compressor manifold and hardware in a safe place and leave cover plate on compressor at this time.

- Do not connect clutch wire or apply power to clutch wire without the hoses connected and system charged – Serious damage will occur to compressor.

Compressor Oil

Although the compressor is supplied with oil, the level may not be correct for the entire system. Consult the instruction manual of the air conditioning unit for proper levels and system charging procedures.

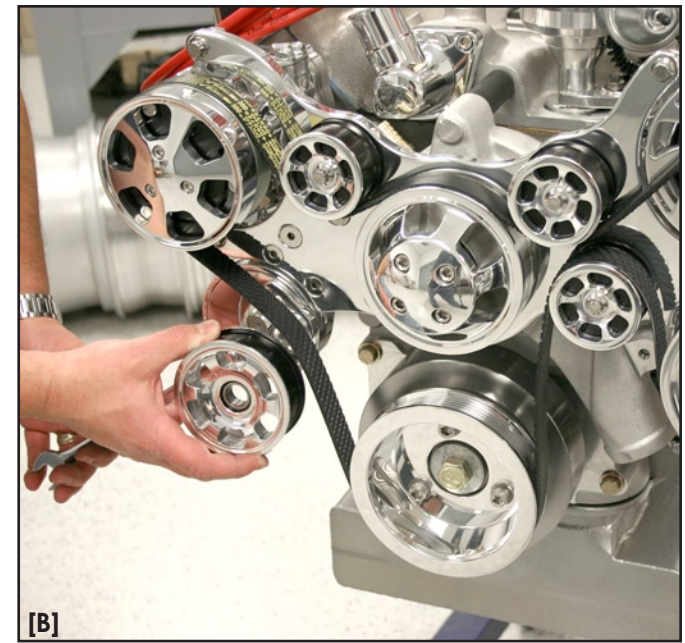
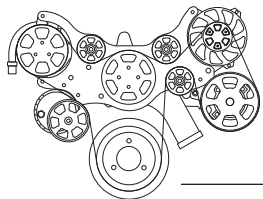

FIGURE 15: Install Tensioner Pulley & Belt

Apply anti seize to one 3/8-16 x 3/4" ARP 12pt cap screw.

Route serpentine belt as shown below; minus tensioner.

[A,B,C] Place a 5/8" box end wrench on tensioner. Align belt onto pulley and push down until tensioner pulley slips onto tensioner shaft.

[D] Slowly return wrench to starting position to apply tension to belt, remove wrench and install the 3/8-16 x 3/4" ARP 12pt. bolt with thrust washer onto pulley, tighten firmly. (46 ft/lbs)

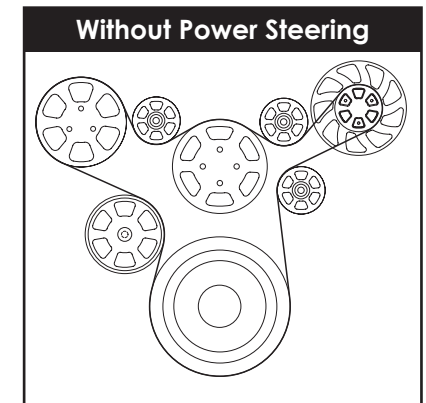
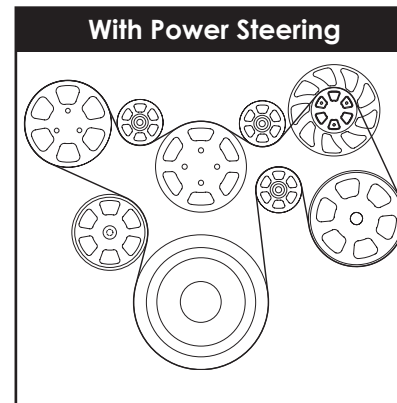

#14700 / #14720



Billet Specialties, Inc.
500 Shawmut Avenue
La Grange, Illinois 60526
Tech Line 708.588.0505
Fax 708.588.7181
www.billet specialties.com

