

Southwest Speed Power Steering Box Instructions 1955-1957 GM Passenger Cars (SWS # 105-3332)

Notes:

This kit is designed to work with manual steering center link.

Instructions:

1. Remove the pitman arm from the steering box.
2. Remove the pressure and return hoses from the steering box.
3. Remove the coupler (rag joint or U-joint) from the steering box.
4. Remove the steering box from the car.
5. Bolt the new steering box to the frame.
6. Check that the front of the steering box is not making contact with the edge of the frame. If the steering box is making contact with the frame, the edge of the frame may need to be altered slightly for clearance. The diagram illustrates where some frames will interfere with the steering box. **Warning: Do not attempt to grind or modify the steering box!**
7. Connect the coupler (rag joint or U-joint).
8. Connect the pressure and return fittings.
9. Install the pitman arm.
10. With the engine running, check for leaks at the hose fittings. To do this have someone in the car hold the steering wheel tight against the left and right steering stops. This will operate the box at full pressure.

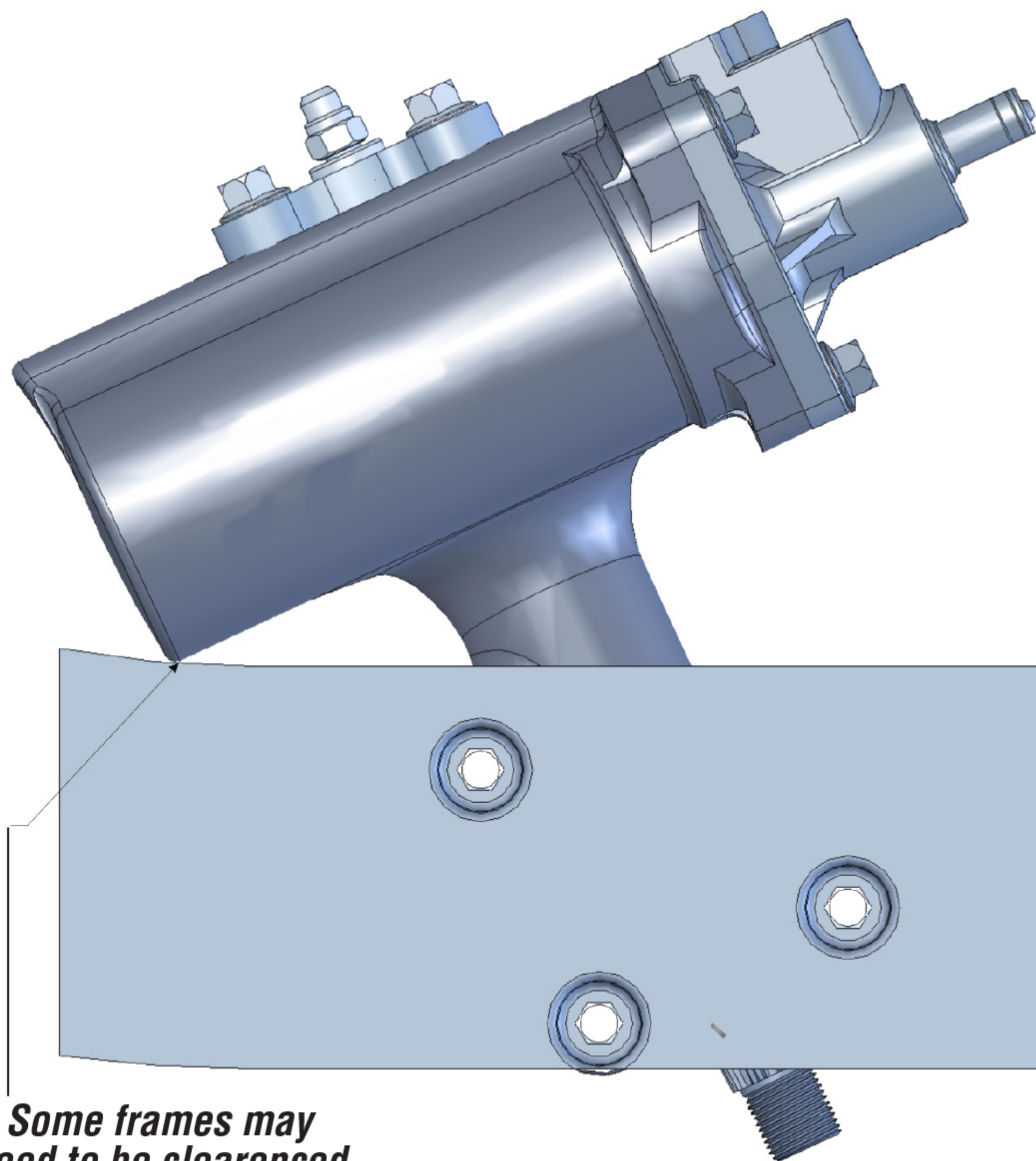

Some frames may need to be cleared here. Do not grind on the steering box!