



Natural Draft Diesel Heater Operating and Installation Instruction Manual



KEEP THIS MANUAL FOR FUTURE REFERENCE

Lofoten, Newport, Alaska, Antarctic Models

**** Please read from beginning to end before installing and operating**
For Marine Use Only**

Heater's Serial #: _____

Table of Contents

- Warnings... Pg. 3**
- 1. About a Natural Draft Diesel Heater... Pg. 4**
 - 2. Important Notes... Pg. 4**
 - 3. Ventilation... Pg. 5**
 - 4. How does the Chimney affect the Heater... Pg. 6**
 - Testing your Draft... Pg. 7
 - Downdraft... Pg. 7
 - 5. Installing your Heater... Pg. 7**
 - Location... Pg. 7
 - Safety Clearances... Pg. 8
 - Facing Direction... Pg. 8
 - Location Diagrams... Pg. 8
 - Mounting... Pg. 9
 - Chimney Pipe... Pg. 9
 - Chimney Pipe Diameter... Pg. 9
 - Barometric Damper... Pg. 9
 - Deck Fitting... Pg. 11
 - Deck Fitting Diagram... Pg. 11
 - Exhaust Cap... Pg. 11
 - Heater Installation Diagram... Pg. 12
 - 6. Fuel System Installation... Pg. 13**
 - Fuel Supply & Overflow... Pg. 13
 - Fuel Filter & Manual Shut-off's... Pg. 14
 - Fuel Supply... Pg. 14
 - Gravity Feed... Pg. 14
 - Fuel Pump... Pg. 14
 - 7. Walbro Pump Installation... Pg. 15**
 - Walbro FRD-2 Pump Upgrade... Pg. 16
 - Exploded Fuel Pump Diagram... Pg. 17
 - 8. Draft Assist Fan Installation... Pg. 18**
 - Fan Diagram... Pg. 18
 - 9. Water Coil Installation... Pg. 19**
 - Water Coil Diagrams... Pg. 20
 - 10. Heater Operation... Pg. 21**
 - Burner Assembly Parts
 - Lighting Procedure... Pg. 22

11. **Approximate Valve & Fan Settings...** Pg. 23
 - Fire Diagram... Pg. 23
12. **Operation Tips...** Pg. 24
 - Importance of the “Fuel to Air” Mixture... Pg. 24
13. **Flooding the Burner...** Pg. 26
 - Valve Height Requirements Diagram... Pg. 26
14. **The Oil Metering Valve & Fuel Flow...**Pg. 27
 - Safety Fuse... Pg. 27
 - Fuel Adjustment... Pg. 27
 - Fuel Flow Measurements... Pg. 28
 - Fuel Variations... Pg. 28
 - Valve Operating Ranges... Pg. 29
 - Valve Repair Kits... Pg. 29
 - Valve Repair... Pg. 30
 - Exploded Valve Diagram... Pg. 32
15. **Burner Assembly...** Pg. 33
 - Burner Diagram... Pg. 33
16. **Maintenance...** Pg. 34
 - Fuel Checklist... Pg. 34
 - Cleaning the Burner... Pg. 34
 - Cleaning the Fuel Lines... Pg. 35
 - Exterior Surface... Pg. 35
 - Replacement Parts... Pg. 35
17. **Trouble Shooting/ using low sulfur diesel?...** Pg. 36 & 37
18. **Warranty Policy...** Pg. 38-40
19. **Registering your Warranty...** Pg. 41

WARNINGS

- Do not operate this heater unattended.
- Turn off the heater when refueling.
- Do not burn gasoline.
- When operating the heater there MUST be an open fresh air vent.
- Do not light a warm burner or it can result in an explosion.
- Do not use a pressurized fuel tank.
- Do not plug the overflow fitting.
- Install a CO alarm.
- Follow ALL installation and operation procedures.
- Use only Stainless Steel Chimney parts

1. About a Natural Draft Diesel Heater

A Dickinson diesel heater has many advantages to other heating appliances. They can be run on no power but has a 12v draft assist fan to provide draft assistance. Our heaters are equipped with simple but reliable internal components including a gravity feed oil metering valve to a vaporizing oil burner where the fuel vaporizes by natural draft to burn a beautiful clean fire in the viewing combustion chamber. A vaporizing oil burner is designed to transform oil to a vapor state and then burn the vapor. Vaporizing is achieved by the oil reaching 465 F. Once the oil is vaporized, it becomes flammable and an efficient and clean combustion is the result.

To obtain a clean and efficient combustion, 3 factors must be in a balanced proportion.

1. **Draft**- the volume of air rising through the exhaust chimney.
2. **Oxygen**- replacement supply of fresh air.
3. **Fuel**- Input in proportion to the supply of draft and oxygen.

Dickinson diesel heaters can also be calibrated to run kerosene (K) and stove oil (S). See “Fuel Variations” on Pg. 27. This code will be indicated on the side of the valve.

A hot water coil can be factory installed or added later to also enjoy water heating from your Dickinson diesel heater. Hot water coils are available in a 1 turn coil for all model heaters to heat approx. 5-10 gallons of water. Hot water coils are also available in 2 turn coils for only the Antarctic and Lofoten models to heat approx. 15-20 gallons of water.

2. Important Notes

Here are some important notes to remember when installing a Dickinson diesel heater:

- Mounting & location, 12v power hook-up, minimum 4ft and a maximum 8ft of chimney, the location of hole for the chimney & the fuel supply.

- **VERY IMPORTANT: Unrestricted permanent fresh air inlet required to draw in outside air needed for correct operation.**
- Fuel must be filtered and not exceed a pressure of 4 psi or a fuel pressure regulator must be used to avoid dangerous flooding (Dickinson part# 20-003).
- A barometric damper must be installed to help regulate the draft. A barometric gives you more control in the “fuel to air” mixture needed for correct operation. The valve controls the fuel whereas the fan increases the air and the barometric decreases the air (See Pg. 9).
- Install a CO alarm.

*** Low Sulfur Diesel Fuel Baffle maybe needed if using low sulfur diesel.

4. Ventilation

Do NOT operate this heater in an enclosed area without a permanent fresh air inlet designated for your heater. This is required to draw in outside air for correct operation. To guarantee that fresh air is available for your heater, good ventilation is essential. You MUST replace the air inside your boat at the same rate that the heater is removing it. The higher the heater’s burning rate, the more air the heater will require. If the air flow is blocked or restricted, the heater will burn inefficiently, create soot, blow out and can even be a very dangerous health hazard.

A permanently open fresh air inlet MUST be installed or dedicated to the heater. This inlet must be at least 3" in diameter. Ducting to the heater is also an option. It is important to create and maintain a positive pressure inside the boat. High winds can draw air out from the boat and thus create a negative pressure. This condition can result in down drafts. Ensure that when you do have windows open that they do not create a suction effect in the cabin due to the window’s position and the wind direction. In a similar way, it is possible for the air intake on your engine to suck the air out of a cabin if it is not properly vented. Your heater is a natural draft appliance and it creates its draft pressure like a chimney in a wood stove. The rising, heated air in the chimney pulls fresh air into the

heater as it rises up the chimney and exits the flue cap. The greater the draft pressure, the more able the heater will be to resist strong winds, overcome flue elbows that inhibit draft and the hotter you will be able to get your heater without sooting. A CO alarm should be installed in the boat. We also recommend the Dickinson high heat shut-off #02-210.

4. How Does the Chimney affect the Heater?

The heater does not create the draft for a natural draft appliance to operate; it is the chimney that creates the draft for operation. The purpose of a chimney is to take the combustion products (smoke and gasses) from the appliance to the atmosphere outside your boat, and at the same time, to draw air in for combustion into the appliance. This movement of combustion air and exhaust is called draft.

In essence, it is the difference in pressure between the air inside the chimney flue and the outside air that creates this movement. Warmer, lighter gases in the flue will move upward.

To keep the pressure conditions favorable, we need a tall column of warm air inside the chimney, and cooler air outside. The warm air will tend to rise, drawing the exhaust from the appliance out. As air exits the chimney, fresh air for combustion is drawn into the appliance. The stronger the upward draft in the chimney the more likely you won't experience downdraft.

Important Factors of the Chimney

Since draft is a measure of pressure, chimney draft is affected by pressure conditions in the boat. Several factors come into play:

1. **Adequate air.** First, there must be adequate air movement into the boat to make up for the air exiting through the chimney. If the boat is very tightly insulated, the volume of air drawn up the flue will exceed the volume of air entering the boat, and the boat will gradually become depressurized. With lower pressure in the boat than outside, there will be a tendency for air to be drawn back into the boat from all available openings including down the chimney.
2. **Air movement in the boat.** Second, air movement in the boat must not interfere with the chimney. As air flows out through the one window, air is drawn from another to replace it. This is called the stack effect, since the boat acts like a stack, or chimney. If the stack effect is powerful enough, it will overcome the chimney's upward

draft and pull replacement air (and smoke) into the boat through the chimney.

3. **Competition for available air.** Third, there must not be too much competition from other devices in the boat, such as exhaust fans, a large engine or air-exchange systems. If something else is sucking the air out of the boat, the chimney might not be powerful enough to overcome it, and exhaust might be drawn into the boat from the chimney.
4. **Proper chimney design.** And finally, a chimney must be designed to accommodate the volume and type of exhaust being emitted by the appliances it serves. This involves correct sizing, adequate height, and proper construction. See the “Chimney Pipe” section on pg. 9.

Since the chimney draft is affected by so many factors, draft problems can be complicated to find.

Testing the Draft

To find where the air is being drawn, twist a paper towel into a wick, light it and blow it out to create smoke. Placing the smoking wick near the open hatches, windows or vents will lead you to the location. Installing or opening opposing vents will allow the air to come in from a path of least resistance and not disturb the draft in the chimney.

Downdraft

A common reason for downdraft is burning the heater too low (too much air in the burner and not enough fuel). If the flames are burning below the top burner ring and inside the burner pot then it is burning inefficiently causing the draft to be too weak going up the chimney allowing downdraft down the chimney. When the flames are burning above the top ring then the natural draft is at its strongest so it can fight against downdraft.

5. Installing your Heater

For Marine and Recreational Use only. Check your local laws and regulations for installation requirements.

Location

Plan your heaters location prior to installing to ensure the location chosen will fit the specifications and safety clearances. Combustible material closer to the heater than the specified safety clearances must be lined with insulation or cement board and a metal liner with a .5" standoff for air movement behind. Another alternative is using insulation or cement board and ceramic tile. The wall behind the heater and the first length of chimney pipe should also be lined with such material. See diagram below.

Safety Clearances

Above- 30", In front- 18", Sides- 12", Below- 6"

Facing Direction

The heater ideally should face the bow or stern of the boat, particularly on a sailboat. Fuel is gravity fed from the oil metering valve into the burner so if the valve should drop below the level of the burner, the fuel would not flow uphill into the burner, which will put out the fire. In a beam-facing installation, the oil metering valve may have to be relocated to the side of the heater. There are holes located on the side to hold the repositioned valve bracket. See diagram below. This will allow the heater to operate up to 15 degrees. If you have any doubt regarding the need for a valve bracket, please email us. info@dickinsonmarine.com

Note: the heaters valve & burner should be in line with the boats keel.

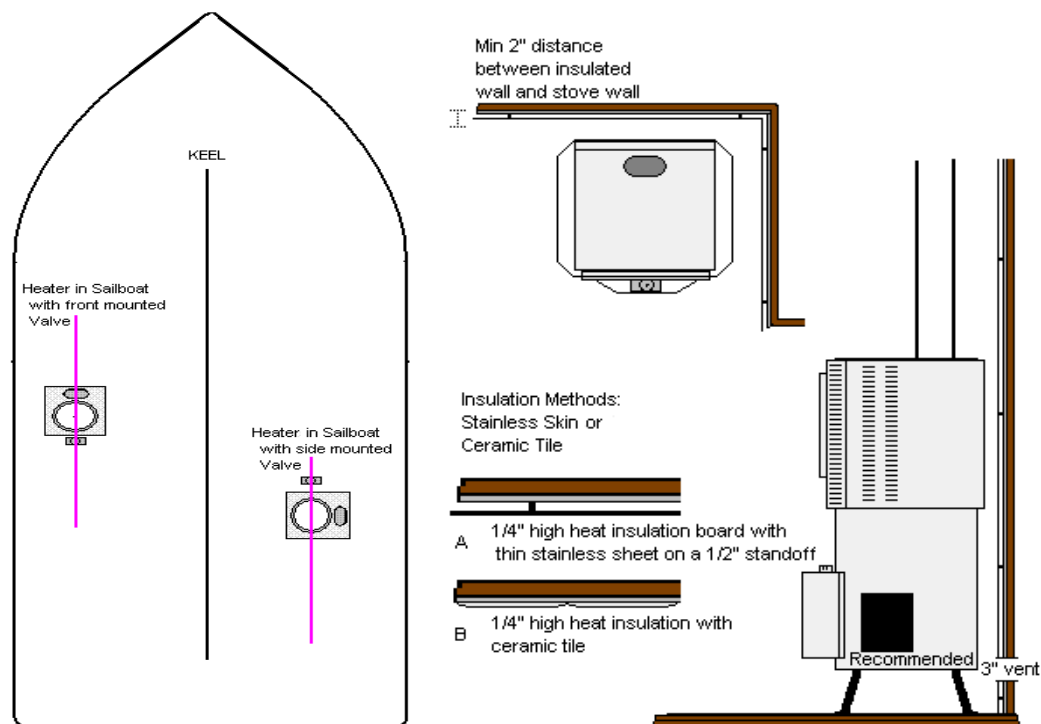

Mounting

There are holes provided in the feet of the heater to allow appropriate fasteners to secure it to the floor. The Newport model has the appropriate brackets to secure the heater to the bulkhead. The drip tray will then fit under the bottom of the heater.

*The Newport bulkhead heater must be secured with the rear mounting brackets supplied.

* All other model heaters must be secured to the floor through the bolt holes in the legs.

**REMEMEBER: remove all protective plastic on ALL parts of the heater.

Chimney Pipe

The location, material and configuration of the chimney stack is very important to the operation of the heater. A long, straight chimney stack will ensure a strong draft for correct operation. The diameter of the chimney must be what is specified and we recommend using stainless steel chimney sections. We further recommend that the length of your chimney is a straight 5-6ft run with a minimum of 4ft long and a maximum of 6ft for 3" diameter chimneys and 8ft for 4" diameter chimneys. Avoid using elbows and if necessary, use 45 degree elbows and allow for as much straight pipe as possible with a minimum of 20" (71 cm) from the top of the heater. There is no connector to connect the chimney pipe to the heater. There is a flue collar already attached to the top of the heater and the pipe can attach by squeezing the pipe into an oval shape and fitting it over the flue collar.

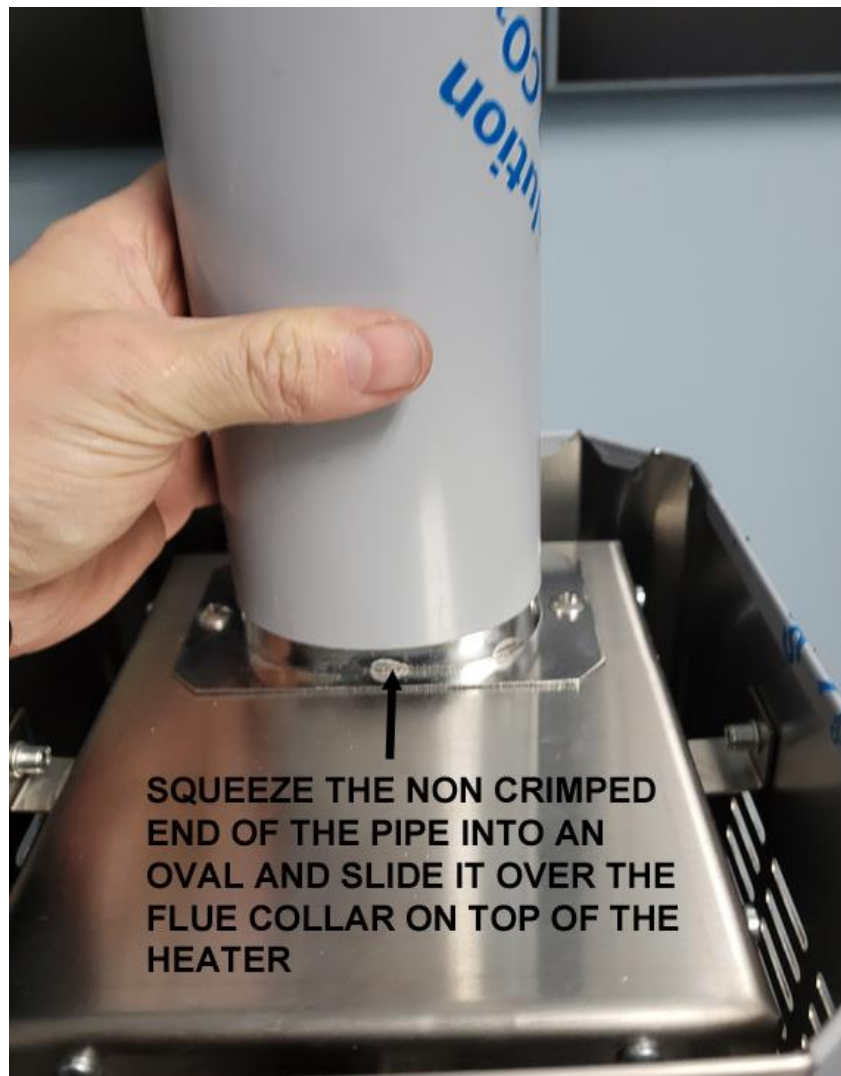

Chimney Pipe Diameters

Newport, Alaska & Antarctic Heaters- 3” diameter stainless steel chimney (7.5cm)

Lofoten- 4” diameter stainless steel chimney (10cm)

*****NOTE - The non-crimped end of the pipe is mean to be mounted to the flue collar on top of the heater*****

Barometric Damper

We have 2 options for installing the barometric damper into your chimney. You can either have the barometric attached to a 22” stainless pipe to be the first piece of pipe of your chimney off the top of the heater or a 7” piece of pipe that you can fit into your chimney 12” to 24” from the top of the heater.

Alaska, Newport & Antarctic model heaters

Part# 16-001: 3” x 22” stainless pipe with barometric

Part# 16-010: 3” x 7” stainless pipe with barometric

Lofoten model heater

Part# 17-001: 4” x 22” stainless pipe with barometric

Part# 17-010: 4” x 7” stainless pipe with barometric

The barometric damper should be installed in oil and solid fuel heaters. The purpose is to maintain a strong draft without causing too much air to the “fuel to air” mixture. When the damper is adjusted, the draft is altered by allowing air to be pulled into the chimney by the air inlet on the damper and not pulled into the burner. This gives you more control. Having a barometric allows you to burn your heater at lower temperatures giving you the control to adjust the draft once the fuel is adjusted to ensure a clean burn.

Install the barometric tee pipe with the front flap facing fore and aft. In order for the barometric to work efficiently it must be installed between 12” and 24” from the top of the heater. If using a flue guard, turn the barometric tee to the back as it does not have to be seen to work

To adjust the flap on the barometric, back off the jam nut and turn the counterweight so the flap is standing closed. Once the heater has been burning for some time and the room temperature is starting to rise, it is a good time to do the adjustment. Adjust the counterweight so the flap starts to

open (aprox 6mm or 1/4"). This will allow air to enter the barometric tee and reduce the air entering the burner. This will help the flame to burn above the top burner ring. If the flame is still burning below the ring, adjust the flap open another 3mm or 1/8". At this time, if there is flames burning below the top burner ring and the barometric flap is open aprox 9mm or 3/8", do not adjust the flap open any further and increase the valve setting until the flame is burning above the top ring.

Deck Fitting

To install the thru deck fitting, a hole must be cut in your deck. Depending on the diameter of the chimney stack will depend on the size hole that needs to be cut. There should be a 1" clearance all around the chimney pipe. For example, a 3" diameter exhaust pipe would require a 5" hole drilled in the deck and a 4" pipe would have a 6" hole. Once a hole is cut, you can line the raw hole with epoxy, caulking or a metal liner to finish it off. Just ensure there is a 1" air gap between the side of the hole and the chimney pipe.

The thru-deck fitting includes a stainless steel dress ring for the interior of the cabin and a neoprene rubber gasket to better seal the fitting on the deck side. Depending on the contour or the angle of the cabin top, you may need to make a hardwood spacer block. One surface of the block would be a level plane to mate to the deck cap. The other would match the angle or contour of the cabin top. A hole through the center of the block would also be 2 inches greater then the diameter of the flue pipe.

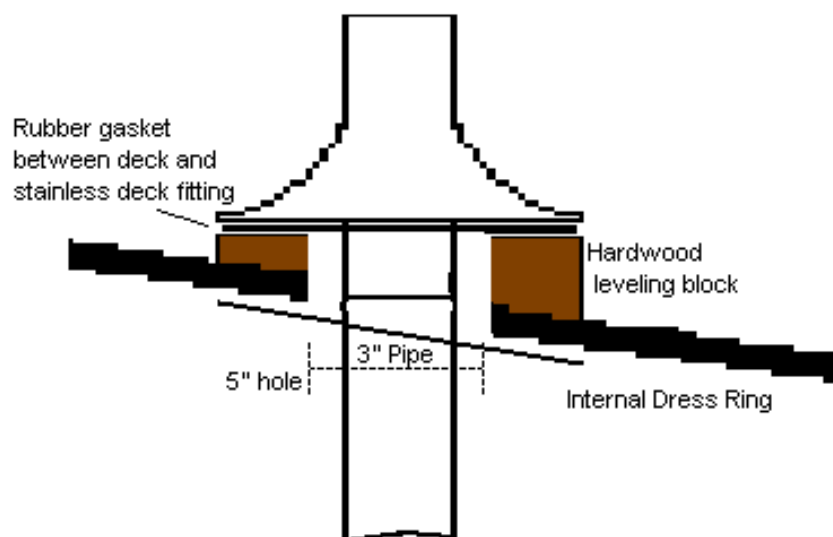

***The Lofoten model has a 4" diameter pipe so it would need a 6" hole.**

Exhaust Cap

The Dickinson DP or H style exhaust caps are most recommended. The exhaust cap will fit over the crimp on the deck fitting or flue pipe. The location of the exhaust cap above deck must be clear of any immediate obstruction that may cause unusual air movement or turbulence. CAUTION: The Exhaust Cap gets hot when the stove is operating.

Heater Installation Diagram

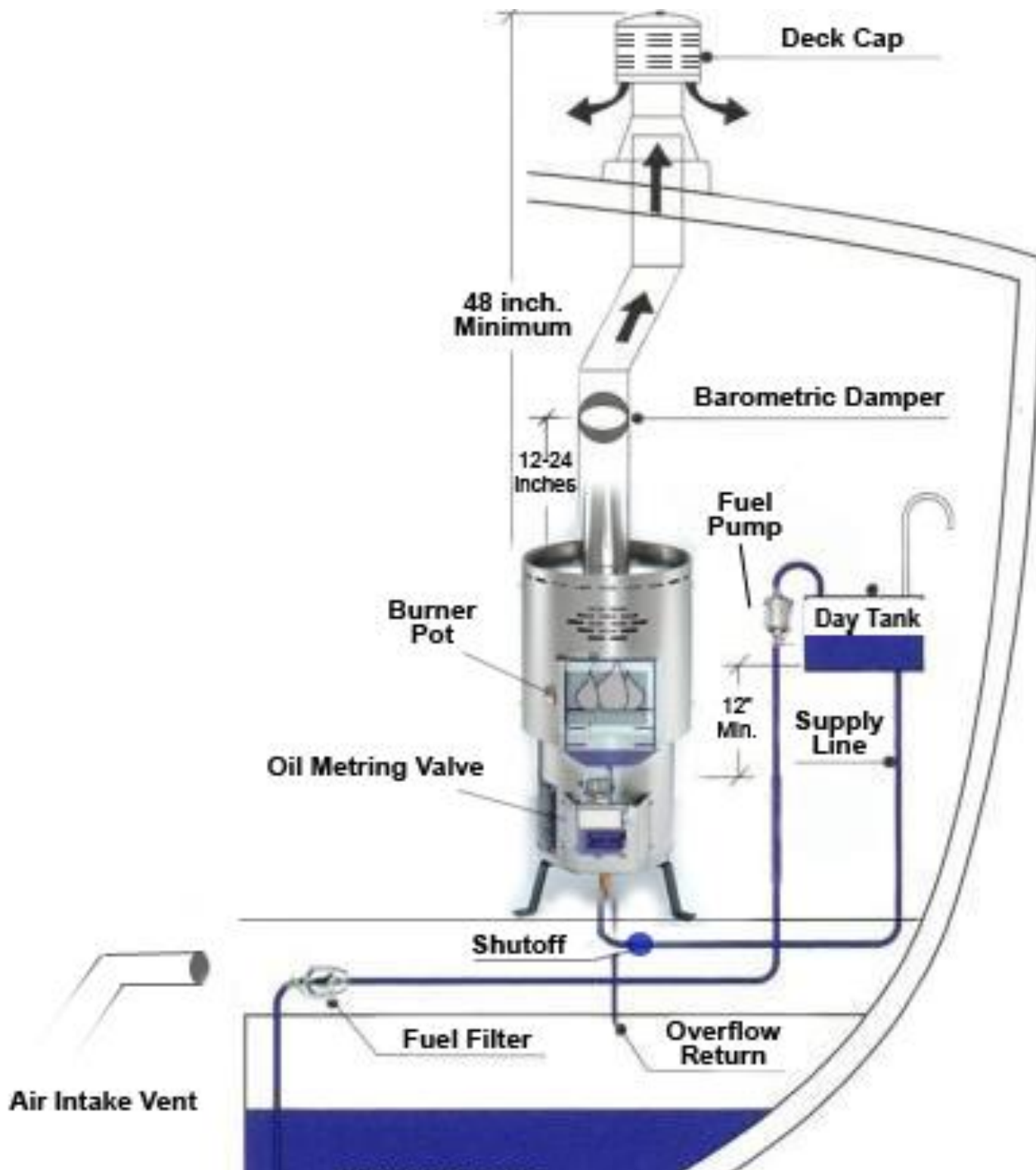

6. Fuel System Installation

For efficient and safe operation of the heater, follow all recommendations for properly installing the fuel system.

DANGER: Never use gasoline in a heater. Use only #2 diesel, #1 stove oil or kerosene. The valves are factory calibrated to #2 diesel; if #1stove oil or kerosene is preferred you would need to order a valve stem or new valve specifically manufactured for your specific fuel viscosity.

*** If in colder temperatures it may be wise to burn kerosene or add fuel additives to your fuel to keep the fuel viscosity thin for correct operation. In some cases, a valve with a higher flow rate may be needed.

Fuel Supply & Overflow Feature

The fuel supply fitting on the oil metering valve is a 3/8" (10mm) flare fitting and the overflow is a 1/4" (6mm) flare fitting. To make these connections you will need a flaring tool to connect the 3/8" flare nut as well as a 1/4" flare nut. 3/8"OD and 1/4"OD ACR (refrigeration) copper tubing should be used for the first 3 feet of fuel line from the heater. Approved hose can be used for the remainder of the installation. Run the fuel lines as straight as possible to avoid air locks. Check all connections for any leaks.

The overflow safety feature is designed to allow the controlled escape of fuel from the heater in case of over pressurization. If dirt, debris, or too much pressure gets into the needle and seat inside the valve, the fuel will rise and overflow out of the valve and away from the heater. It is common to get a few drips now and then from the movement in rough waters, however, more than a few drops of fuel from the overflow indicates the need to service and clean the valve.

Under NO circumstances plug the overflow fitting!! A fuel line must be taken from the overflow fitting back to the main tank if the fuel is supplied from the main tank. If the fuel is supplied from a day tank, then run the overflow line to a container away from the heat source. The fuel overflow is a gravity escape. Do not install the overflow line so that it goes up or in loops as this will cause an air lock and block the fuel from escaping. Plastic, rubber or copper tubing may be used for the overflow line.

Note: If the your fuel tank vent or fill tube is higher than the valve of the heater, and the overflow of the heater goes back to the main tank, there may

be a chance when re-filling that the fuel will back flow up the overflow and out of the valve. For this reason a manual shut-off will need to be teed in the overflow line and closed when refilling tanks. Do not use a check valve. Remember to re-open the shut-off valve on the overflow line.

Fuel Filter & Manual Shut-off's

The fuel must be filtered before the fuel pump and before the oil metering valve to prevent dirt and debris from plugging up the check valves in the pump and the needle and seat in the valve. There also must be a manual shut-off by the tank and also close to the heater as the pressure on the needle in the valve will wear it out faster. We can supply a ¼" NPT fuel filter with a shut-off for close to your heater for this purpose. (Part# 20-010) The 15 micron stone element in the filter (part#20-020) should be replaced every 1-2 years.

Fuel Supply

The fuel can be supplied to your heater by either your main tank or a day tank and fed with either a fuel pump or gravity depending on your install.

Gravity Feed

When using a gravity tank, there should be a minimum head of 12" (30.48 cm) above the fuel level marked on the side of the oil-metering valve to operate correctly. The gravity feed tank must be vented and all fuel lines must be as straight as possible to avoid air locks. Do NOT use a pressurized tank.

The oil metering valve is rated to an incoming fuel pressure of 3 psi. If the pressure exceeds 4 psi, a pressure regulator will be needed in the supply line. (Part # 20-003) If installing a gravity tank larger than 30gal or higher than 8 feet above the valve of the heater, you will also need a pressure regulator.

Fuel Pump

When a low pressure fuel pump is used, a fuel line must be tee'd in as close to the fuel tank as possible, not from the engine supply line or engine filter. Use a check valve in the heater fuel line to stop the engine from pulling back the fuel and starving the heater.

7. Walbro Fuel Pump Installation

When installing a Walbro fuel pump you must ensure it is mounted approximately at the level of the valve on the heater. These pumps can “pull” fuel but have trouble “pushing” fuel so it must be gravity fed from the pump to the heater. The lift and the climate will then indicate if you need the standard pump (part#20-000) or the heavy duty pump (part#20-002). We highly recommend the heavy duty pump for all installs so you have the option of adjusting the pressure if needed.

The standard pump Walbro’s FRD-2 part# 20-000 is a 12v DC pump with a pressure of 3psi. It is for a standard installation where the climate is fair and fuel run from the fuel supply to the pump is less then approx. 4ft vertical and 15ft horizontal.

The heavy duty pump part# 20-002 is Walbro’s FRD-2 12v DC pump with a factory retrofitted pressure spring and an adjustable pressure regulator installed for a higher pressure pump for a heater installation in a colder climate and where the fuel run from the fuel supply to the pump is higher then approx. 4ft vertical and 15ft horizontal. This pressure regulator will adjust the pressure higher or lower to the oil metering valve.

*If using the heavy duty fuel pump part# 20-002, the adjustable pressure regulator attached has a thread size of 1/8” NPT. It is soft die cast aluminum so use caution when connecting the fittings. The numbered settings are only for reference because depending on the fuel supply installation and the climate will depend on the pressure of each setting. Disconnect the fuel line at the valve and allow the pump to push the air out of the fuel line to see a constant flow of fuel going into a bucket. Set the regulator to the lowest setting. Watch the flow of fuel. Adjust the regulator setting until there is a constant flow of fuel pouring into the bucket. If you have adjusted the regulator to the highest setting with still no constant flow of fuel, the regulator can be adjusted. Pierce a hole in the sticker on the center of the knob with a 5/64th Allen wrench and turn the adjusting screw clockwise ½ a turn.

To prime the pump, pump fuel into a container to remove all the air in the fuel lines. After a cup of fuel has been pumped, reconnect fuel line to the valve. If there is no fuel getting to the pump or there’s air in the fuel line the pump can make a chattering noise.

Once the valve is full of fuel and the pressure has been reached the fuel pump will still continue to tick, but less frequent. Once the pressure drops in the valve the pump will then begin to tick more frequent depending on the demand of fuel from the valve. To lessen the noise of the pump pulsing, a rubber backing can be installed.

The pump should be included in a control circuit with a 5 amp fuse so it can be turned off when the heater is not in use. NOTE: If the power to the pump is shut off, the fuel could still flow through to the pump by way of siphon. The flow of fuel should be turned off using the shut-off valve near the heater as well as the oil metering valve.

The pumps can be installed with fuel inlets and outlets up or down, however mounting the pump with the fuel inlet (spout looking side) on top will give the pump extra pressure and is easier to clean. The pump will need to be primed the first time only to remove air in the fuel line. There are 3 check valves in the pump to prevent the back flow of fuel, so the pump should stay primed. If the pump does not stay primed then 1 of the check valves in the pump needs to be cleaned

The pump should be installed in a ventilated area and not near a hot exhaust. Connect the ground to a negative battery. This pump is not recommended for gasoline.



Walbro FRD-2 Fuel Pump Upgrade

To upgrade a Walbro FRD-2 (part#20-000) to a Heavy Duty pump (part#20-002) a factory spring & regulator must be installed. If you find you are not getting fuel to the valve with the FRD-2 standard pump you may need the stronger pump with the stronger pressure. Please contact Dickinson to order a stronger spring & regulator. info@dickinsonmarine.com

Once you have received a stronger spring and regulator from Dickinson, you can upgrade your pump to a stronger pressure. Unscrew the 3 torx screws (t-20) and with twisting the lid back and forth, pull it straight back off. Note the pump plunger, spring, check valve, and a very small amount of fuel will drop out if installed as per diagram. Place the check valve as shown in the diagram on top of the heavier replacement spring, and the spring on top of the pump plunger and push it back into the pump body holding it in with a finger. Note the magnetic part of the plunger is on the opposite end of the

spring. Replace the lid with the gasket on by lowering your finger on to the red O ring sleeve without the plunger falling out (the plunger is about 2" long so you have room to lower your finger out of the way). The red O ring sleeve will fit inside the pump tube and the black O ring will fit over the outside of the pump tube and will require twisting and pushing the lid straight back in. This is a little tight but that is what makes the seal. Rotate the gasket and replace the screws.

Now that your standard pump is upgraded to a heavy duty pump it must be primed. When priming the heavy duty pump hold down the knob of the pressure regulator to prime the fuel lines to take out the air. Then turn the dial to the lowest setting on the regulator and increase the pressure one increment at a time until the pump is just delivering a constant flow at the heater.

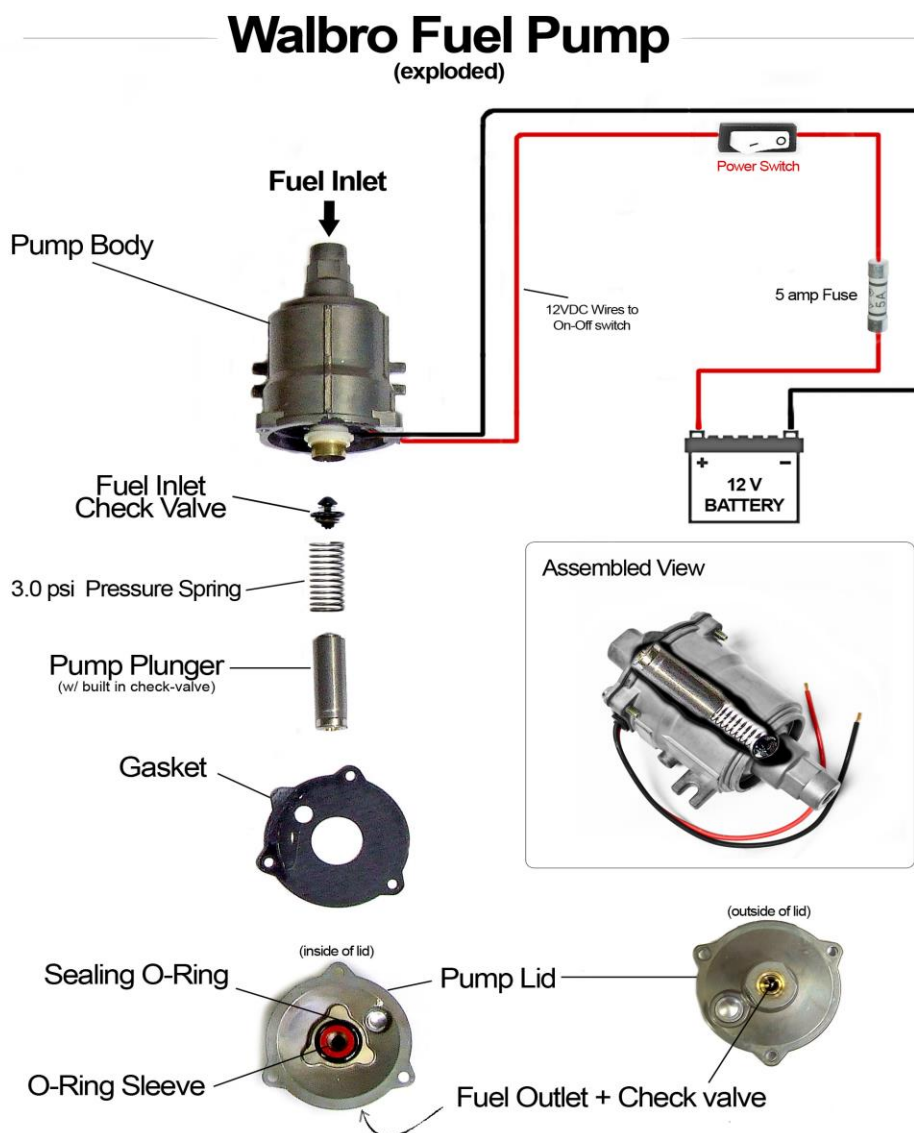

8. Draft Assist Fan Installation

The 12v draft assist is not needed for operation but highly recommended as it will help to vaporize the fuel and give more control in burning the heater as clean as possible. The fan is a 12v DC fan that the draw is .17amp. The fan is 12v and if 24v or 32v is needed, resistors are available. This fan is rated for 8000 hours and is only for start up and for higher temperature settings as using the fan all the time will burn it out prematurely and make hard carbon deposits inside your burner pot clogging up the air holes causing the heater to not operate correctly.

When turning the fan on, turn it up to a faster speed first, then you can adjust it back down to a slower speed as this gets the fan blade going.

Whenever possible, ensure a weatherproof connection between wires with solder or the appropriate connectors with 18awg wire. The motor mount 'bushing' washers should be placed in between the mount bracket and the main housing NOT between the mount bracket and the head of the fastener.

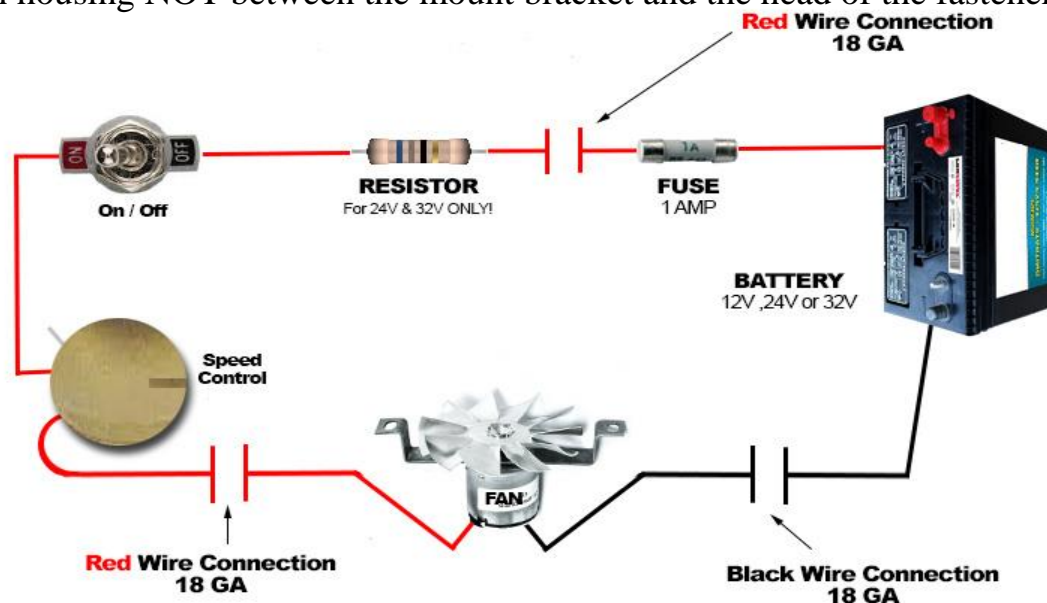

During start up, operating at higher settings or during windy conditions, you want to use the combustion assist fan on your heater to artificially boost the draft. Your heater should operate without the use of the fan on lower temperature settings. Some heater installations with only the minimum flue heights or with flue elbows that inhibit the draft may need the use of the fan more often.



9. Optional Hot Water Coil Installation

A hot water coil can be added to also enjoy water heating from your Dickinson diesel heater. You can either order your heater with one already installed in the heater or you can install the coil later yourself. Hot water coils are made of 5/8" OD stainless steel tubing and are available in a 1 turn coil for all model heaters to heat approx. 5-10 gallons of water. Hot water coils are also available in 2 turn coils for only the Antarctic and Lofoten models to heat approx. 15-20 gallons of water. To plumb the hot water to the heater, 1/2" copper tubing should be used with the compression fittings provided.

The coil in a heater can be used to heat the water in your existing hot water supply tank. If the tank is mounted above the lower coil, the water will circulate on its own from the tank into the hot coils and rise back into the tank by convection. If not, the water will need to be circulated by a low volume water pump. The temperature of the water will change depending on the speed of which it's circulating and the operating settings on the heater.

It takes approx. 3000 btu's to raise 10 gallons of water to 30 degrees in 1 hour. Most of the btu's that the heater produces is dissipated as radiant heat and is expelled through the chimney. Therefore, only a general guideline as to water heater capability can be set.

WARNING: A pressure relief valve must be present or dangerous pressure buildup will occur.

* See typical coil install diagrams on pg. 20*

It is best to order the heater with the coil already installed but follow these instructions for replacing or installing a new coil.

1. Remove the nuts holding the outer shield and open the front door to manipulate the front and back shield off the Newport and Alaska model heaters.
2. Remove the top baffle from inside the firebox.

3. Punch out the 2 knockouts on the back of the heater or drill them if not there.
4. Fit the coil inside the firebox and through the 2 holes in the back panel leaving about 2" sticking out the back.
6. Replace the baffle. This keeps the coil in place until the coils are connected. It is important that the coil be positioned so there is a constant rise in the tube as it goes to the back of the heater. This aids in the movement of the water or glycol. Use the 90 degree compression fittings supplied to connect.

Hot Water Coil Option #1

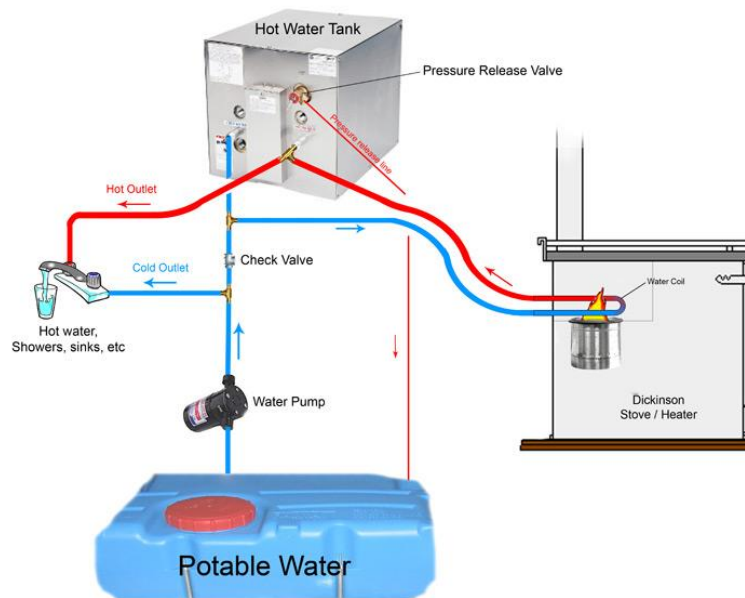

Water Coil Setup Option #2

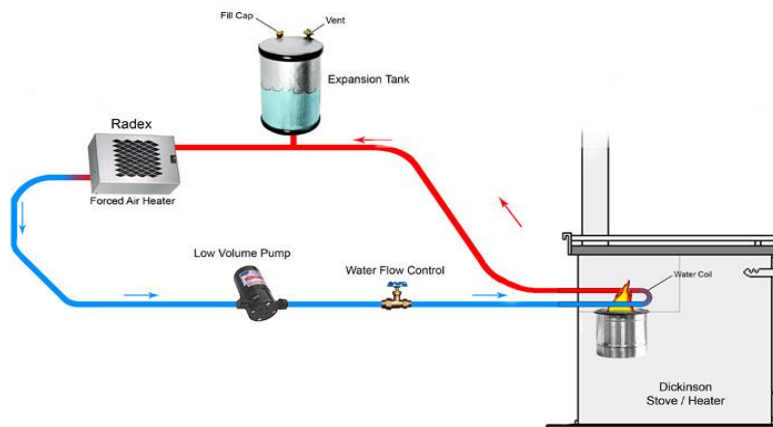

10. Operation

NOTE - THE OIL METERING VALVES ON THE HEATERS ARE STORED DRY SO THE FLOAT IS IN THE OPEN POSITION. WHEN FUEL FIRST FLOWS INTO THE VALVE IT MAY COME OUT THE OVERFLOW AS THE FLOAT MAY HAVE GOTTEN STUCK IN THE DOWN POSITION FROM ALL THE JOSTLING DUE TO SHIPPING.

The first time the oil-metering valve is turned on it will take 5-10 minutes for the fuel lines to fill and oil to appear in the bottom of the burner.

Burner Assembly



Low Sulfur Baffle – Clips into the burner over top of all other parts. Used to deflect more heat down into the burner to vaporize fuel more efficiently



Superheater – Used to transfer heat from the flame above the burner to the bottom of the burner to vaporize fuel. The open ring is the top and the washer that is attached to the legs goes in the bottom of the burner. Good metal on metal contact is necessary for proper heat transfer



Burner ring – Sits in the inner ring located inside the burner. It is meant to sit inside that ring with the spun flange directed downwards.



Burner – Combustion should take place above the burner ring and not down inside the burner. It is essential that the burner stays clear of carbon build up and that the 4 rows of primary combustion air holes are poked out to ensure continuous airflow.

Lighting Procedure

1. Turn on the fuel pump or open the gravity feed valve to allow fuel to flow into the oil metering valve on the heater.
2. Open the door or open the lid and twist the superheater so the bottom makes a good contact with the bottom of the burner.
3. Lift and turn the oil metering valve knob on to setting #5 for 2 minutes to accumulate 2 tablespoons of oil in the bottom of the burner pot.
4. Then turn the oil metering valve OFF.
5. Twist a piece of tissue, light it and throw it into the pool of oil in the burner pot. Use a poking tool to push the lit paper into the pool of oil.
6. Once the oil has ignited, replace the lid or close the door.
7. Turn the draft assist fan on to the medium speed (6 o'clock) then turn it back down to the slowest speed (4 o'clock).
8. After a few minutes, watch the flames grow above the top burner ring where they should burn at all times.
9. It will take approx. 5-10 minutes for the priming fuel to burn. Once the flames drop back down into the burner pot it's time to turn the oil metering valve back on.
10. Lift and turn the oil metering valve knob to setting #2.5 and turn the fan OFF and watch the flames grow back to above the top burner ring.
11. Wait 20 minutes for the heater and chimney pipe to warm up before you adjust the valve further.

*NOTE: The flames must ALWAYS burn above the top burner ring regardless of the valve setting.

*****DANGER: If the flames go out at any point at this stage, turn the valve off and wait 5-10 minutes for the burner to cool. Re-lighting warm diesel or a flooded burner can result in an explosion. *Do not use gasoline or any other flammable materials to light the burner. Do not operate this heater unattended.**

11. Approximate Valve & Fan Settings

Heater Temperature	Valve Setting	Fan Knob Position
Cold Start	# 2 to # 3	Off
Warm Low	# 1 to # 2	Off
Warm Low (cold or windy)	# 2 to # 3	4 to 5 o'clock
Medium	# 3 to # 4	5 to 6 o'clock
Medium (cold or windy)	# 4 to # 5	6 to 7 o'clock
High	# 5	7 o'clock

* Operating the fan can deliver too much air and cause the burner to run too lean (too much air in the fuel to air mixture). If you find that the flames start to burn below the top burner ring, turn the fan down slightly or increase the fuel slightly.

* The fan has a low amperage motor and will need to have the speed control turned up to a faster speed to get the fan blade spinning, then turn it down to the appropriate setting. This also applies, should the fan blade rattle.

* The best low speed setting is at the 4 to 5 o'clock position on the speed control knob. The best medium setting is at the 5 to 6 o'clock position and the best high setting is at the 6 to 7 o'clock position.

* When turning up the valve wait a minute and watch the flames react before adding air.



12. Operation Tips

When operating on the lower temperature settings the burner needs less air. To reduce the air, adjust the barometric damper open wider, turn off the fan, and add more fuel even if you do not want the heat. It is better to make too much heat and dissipate it than to run the burner too lean with flames inside the burner pot as this will result in hard carbon build up and soot. The burner is designed to burn a certain amount of fuel on low and if less fuel is burned, it causes the flames to end up below the ring, inside the burner pot causing an unclean burn.

Turning up the valve in **small** increments will help the draft to catch up with the fuel increases, keeping a good fuel to air mixture, which helps in reducing soot.

When on medium to higher settings, the flames start to look orange with black tips, turn the fan on using the lowest fan speeds, increase air slowly until the flames start to turn yellow and more vibrant.

If you turn the fan on too high the air will burn off all the fuel leaving the flames below the burner ring resulting in carbon soot.

***Remember, the key to burning this heater correctly is to find the right fuel to air mixture. When adjusting the fuel, you must adjust the air to find the correct balance so you have the cleanest burn.

After the heater is well heated and cabin temperature is reaching comfortable temperature, the valve body and the fuel in it will start to warm up and the fuel will become thinner, flowing faster causing the heater to burn hotter. An adjustment will have to be made to turn down the fuel to a lower setting or add more air for a higher setting.

**Please visit our website and view Dickinson Marine's Operation Video
www.dickinsonmarine.com/video.html**

THE IMPORTANCE OF FUEL AND AIR MIXTURE

Many people underestimate the importance of air flow, when trying to operate their diesel stoves or heaters. In order for your heater/stove to work properly, and burn clean, without soot or smoke, it is vital to have adequate air venting in your cabin. You need to find the optimum balance of fuel and air to ensure a clean burn, and correct operation.



WRONG ❌

Tips for correcting....

- Try turning up the fuel in small increments
- Try turning the fan off, or decrease the fan speed
- Add the barometric damper option if absent
- Try opening the barometric damper in 1/4" increments



WRONG ❌

Tips for correcting....

- Try turning down the fuel in small increments
- Try closing the barometric damper in 1/4" increments
- Try turning the fan on or increase the fan speed

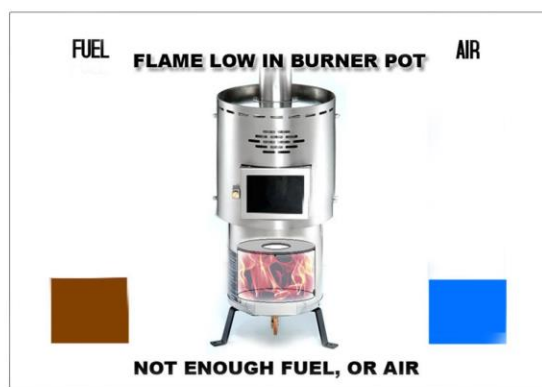

WRONG ❌

Tips for correcting....

- Try turning up the fuel in small increments
- Try turning the fan on or increase the fan speed
- Make sure your cabin has a permanent fresh air vent
- Test your cabin for positive pressure (vent test with a match)
- Make sure your air intake holes in burner are clear of carbon



CORRECT



When operating properly, the flame will be a nice lemon yellow colour and will be mostly above the burner ring, with vapour inside the burner pot.

13. Flooding the Burner

A vaporizing oil burner of this type can be flooded if care is not taken to prevent excess oil entering the burner when lighting. By following the lighting instructions flooding will be avoided. A flooded burner that is still burning should be turned off and the heater monitored until the oil has burned off. Use the combustion assist fan to add air to fully combust the excess fuel.

Reasons that will flood your burner.

- Increasing the fuel supply too quickly without use of the combustion assist fan.
- Poor draft and/or ventilation.

The suggested method to fix a flooded burner is to sacrifice a toilet paper roll as a perfectly fitted sponge and then dispose of the oil soaked roll. For this reason, always monitor the heater closely when lighting.

DANGER: This oil must be removed from the pot before the heater is lit again or the heater will dangerously overheat.

If the flame has extinguished, the oil metering will continue to deliver fuel to the burner causing it to accumulate fuel to a level of 5/8" from the bottom of the burner and no more. Never relight this amount of fuel.

Oil Metering Valve Height Requirements

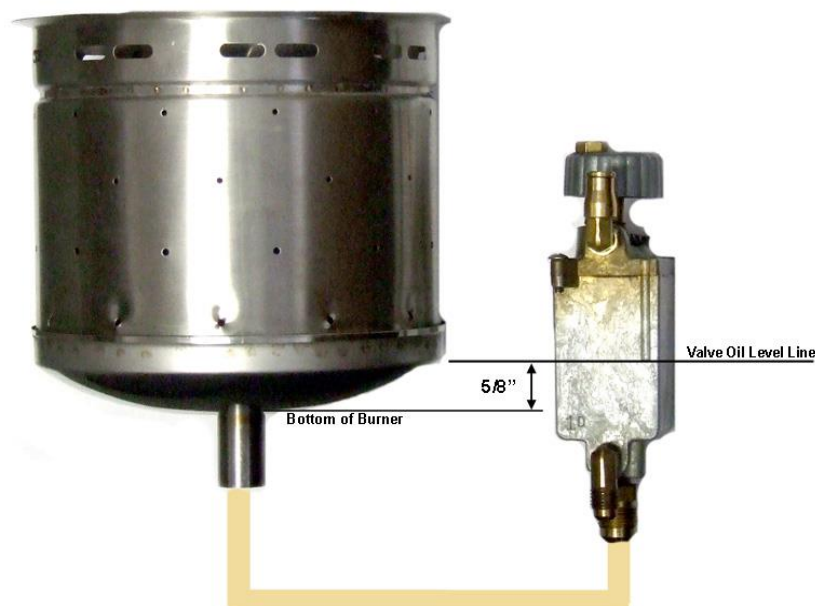

14. The Oil Metering Valve & Fuel Flow

Safety Fuse

A high temperature fuse is incorporated into the oil metering valve. The adjusting screw on the top of the knob of the oil metering valve is fitted with a fusible sleeve. This fuse will melt if the valve knob reaches a temperature of 165 degrees F. This will shut-off the flow of oil into the burner. Under normal conditions, the valve is at room temperature. If the high fire sleeve melts it indicates too much heat is by the valve compartment. Overheating of this kind is due to burning the heater too lean with the flames burning down in the burner pot and should be rectified before the heater overheats again.

In case of the release of the high temperature fuse, remove the brass nut and do not move the adjusting screw. Apply heat from a lighter to re-solder the link back into its original position which was flat on the top. Once back in place the adjusting screw will not need re-adjusting. Make sure to now burn the heater correctly with ALL flames above the top of the burner. See the Operating Tips section of this Manual.

Fuel Adjustment

The height of the valve-adjusting knob will determine the quantity of oil exiting from the valve outlet. The height is determined by the length of the metering screw against the fuel ramp on the main casting of the valve. Remove the anti-vibration set screw (5/64 or 2.5mm Allen key) located in the center of the brass nut on top of the knob (turn counterclockwise). The adjusting screw may be (5/64 Allen) or a very small flat head. Adjust 1/8 turn at a time. After finishing the adjustments, return the set screw using needle nose pliers to hold the adjuster from turning when locking set screw in place

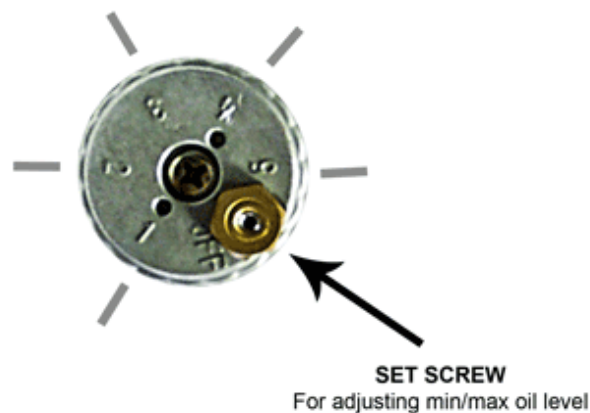

Fuel Flow Measurements

If your heater is burning rich (making soot or smoking) or burning lean (flames not burning above the top burner ring), adjust the valve fuel flow as follows regardless of what type of fuel:

- 1) Unscrew the compression nut from the bottom of the valve with 2 wrenches and bend away the copper fuel line. Allow the oil to drip into a cup or container.
- 2) Lift and turn the valve knob to the #1 setting. Measure the quantity of oil dripping slowly from the fuel outlet.

On Setting #1:

All models	1 teaspoon in 50 sec (4.5 cc per min)
	1.29 IMP Gal per day on low

Fuel Variations

It is unlikely that the fuel you are using is the same viscosity as the fuel used to calibrate the oil-metering valve. Diesel is one of the few fuels you can reliably get all around the world but the quality and viscosity of that fuel is variable. Fuel differs on a routine basis even though you buy the same oil from the same supplier. Factors influencing oil viscosity include: the temperature; the age and quality of the fuel; the regional differences due to local refineries; and the particular mix of certain brands of fuel.

The oil metering valve is calibrated for #2 diesel, unless otherwise requested. Burning diesel #1 (stove oil) will allow 25% more fuel and burning kerosene will allow 50% more fuel to flow through the oil-metering valve. Because of this, it is important to burn the fuel for which the heater has been calibrated. Metering valves are available for diesel (D stamped on the side of the valve), kerosene (K) or stove oil (SO).

It is important to know that although you can re-calibrate your valve to each variation of fuel, you can also adjust the way you operate the heater to compensate for these variations. If the oil is thicker than usual, open the valve more or use less of the fan. If the fuel is thin, run the fan more to burn off the fuel to keep a clean burn.

NOTE: Bio-Diesel is not recommended for use in Dickinson diesel stove and heaters due to the extreme viscosity changes due to temperature changes and the lack of consistency available throughout the different regions. Using Bio-Diesel in your stove/heater can result in but is not limited to clogged fuel lines and oil metering valves, inconsistent burn, lack of heat, carbon encrusted burn pot and rich sooty burn.

Oil Metering Valve Operating Ranges

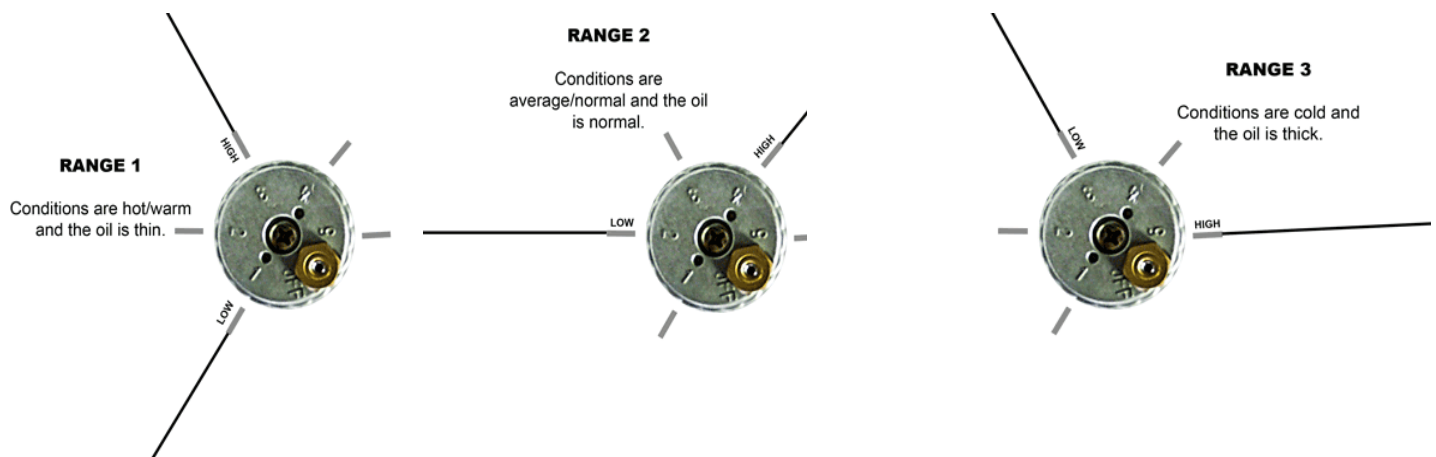

Oil Metering Valve Repair Kits are no longer available.

Oil Metering Valve Repair

The repair kit has been packed with all the parts to rebuild your oil metering valve. The parts may differ in detail from what you have in your valve. This is due to changes and to the unavailability to the parts over the decades.

1. Disconnect the copper fuel lines from the valve inlet and outlet and overflow using 2 wrenches, then remove the valve from the mounting bracket, do not remove the bottom fitting or the overflow fitting from the valve. Unscrew the two retaining screws holding the valve top to the body. Note that the valve top and the valve knob are attached.

2. Remove the float from the float pin; remove the needle from the seat fitting. Using a 5/16ths socket, remove the seats fitting from the valve top casting; however leave the copper washer **in**.
3. Remove the fuel inlet fitting only and clean or replace the stainless screen behind the inlet fitting. Clean the threaded aperture in the top casting to remove any dirt or buildup. Perhaps use a pipe cleaner to clean the path from the inlet hole to the seat fitting aperture.
4. Remove and replace the viton 'o' ring on the valve stem, and clean the stem groove. Clean out the stem guide in the bottom of the valve housing and the overflow tube.
5. Clean the inside of the valve housing castings, top and bottom. Replace oil inlet screen with new and replace the inlet fitting into the top casting (use teflon tape and do not over tighten).
6. In 02-000 kit only, place the small adaptor in over the copper washer and place the new copper/brass washer over the adaptor, then screw in the new seat into the top casting until tight but not so tight as to damage the aluminum threads of the casting (35 inch pounds).
7. Place the new needle in the seat and slide the new float on so the flat bracket groove catches the neck of the needle.
8. Insert the float hinge pin and test the movement of the float up and down and that it moves the needle up and down in the fitting. (When held upside-down, the bottom of the float should be parallel to the casting of the valve, in both directions). This very important to keep the float from binding on the stem guide as it moves up and down. If the float is not parallel to the casting, the float pin tabs on the float will need adjusting. Hold the float firmly and bend the tabs using needle nose pliers, being gentle to not break the float from the tabs (a small crack is acceptable). Bend both tabs down or both up to keep the float level parallel, being careful not to put pressure on the needle and seat when making the adjustments. Check the float for sitting perfectly straight as you may need to bend one tab up and the other tab down in order to achieve the bottom of the float straight in both directions.
9. Replace the top casting into the bottom casting so the metering stem slides in to the metering guide with oil inlet on the same side as the oil overflow.

Replace the 2 top screws snugly, and move the control knob up and down while tightening the 2 screws. Once tight, the control knob should move up and down freely in any position.

10. Measure your fuel flow to the specifications on Pg. 27. Once you have adjusted the flow rate, check the overflow fuel line for oil drips. If the float is operating correctly and adjusted parallel to the casting, the oil level in the valve will be correct. The high fire screw inserted into the high temperature fuse can also be replaced or kept as a spare.

Oil Metering Valve Diagram

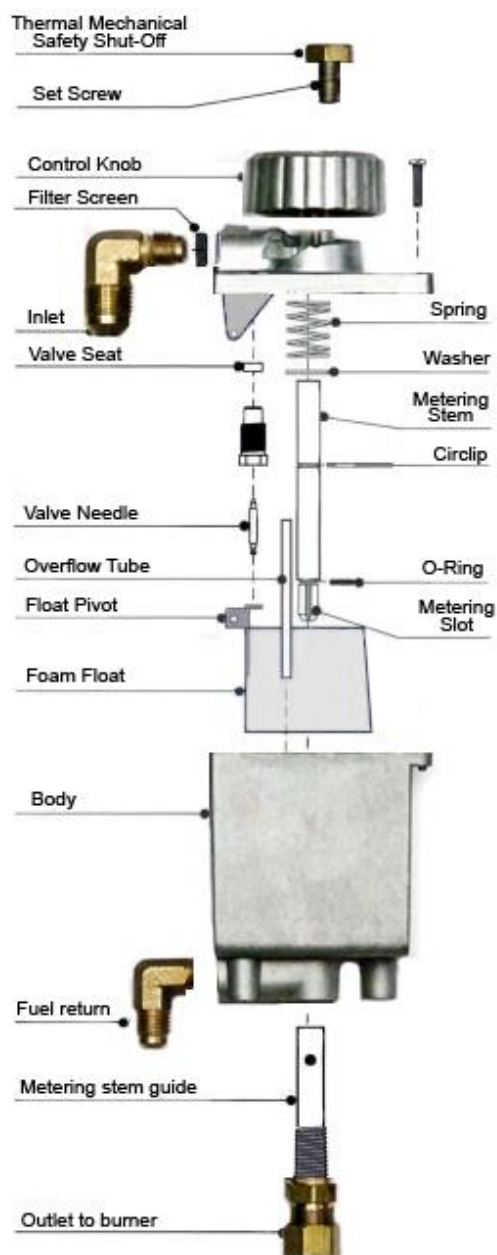

15. Burner Assembly

Your diesel heater has been equipped with a 6" "Airflow" burner. There are two components in the burner that must be correctly placed for the heater to operate properly. The burner ring must be placed at the top of the pot so the outside edge of the ring fits into the groove in the top of the pot. Ensure that the ring fits in evenly and snugly all the way around the pot and that all of the oval shaped slots are clearly visible.

The second component is the superheater. The superheater is placed through the burner ring and will sit on the bottom of the burner with the round 2" disc sitting 2" up from the bottom of the burner. The bottom of the superheater should sit flat on the bottom of the burner to radiate heat to the fuel coming in through the center of the superheater washer. This will need to be kept clean to allow fuel to flow through it. The ring of the superheater will sit up above the burner ring where the flames are and radiate heat down to the vaporizing fuel. The 2" round disc sitting 2" above the bottom of the burner deflects the hot rising vapor up the sides of the burner pulling in the primary air needed to mix with the fuel.





Low or Ultra Low Sulfur Diesel Fuel Baffle

Low sulfur and Ultra Low diesel is now being used in many places and depending on the heater and the chimney configuration, the fuel may be burning differently than it did before.

In every case, checking the operation of the valve, checking the fuel line from the valve to the burner for debris, or clearing the holes in the burner, need to be addressed before assuming it may be the different fuel.

Please perform all troubleshooting before assuming it is a low sulfur fuel issue. Enclosed is a burner baffle that retains heat in the combustion chamber and will speed up the vaporization of these new types of diesel fuels. The baffle is placed on top of the burner edge. Use the draft assist fan more as the fan is needed more to burn off the new type of fuel.

Indications of Low or Ultra Low Sulfur Fuel In-complete Burn

- The flames burn below the top burner ring inside the burner pot.
- Turning up the fuel flow from the valve makes no change to the flames.
- It takes a long time for the flames to go out when the valve is shut off.
- Followed all troubleshooting and still having issues with getting heat.
- Excessive hard carbon in the bottom of the burner

The baffle is included and placed on top of the burners edge after lighting the burner normally so it will speed up the vaporization of the new type of fuel so the reaction to the flames are faster.

The low sulfur fuel requires a little more air, so keep the flames as vibrant as possible. You will soon find what fan settings are best. Do not to use too much air so the flames will fall back into the burner, and create the hard carbon.

There is no way to tell what type of fuel you may have, low sulfur and ultra low sulfur diesel is a yellow-green or a red-brown color.

Make sure to keep a close eye at the fuel accumulation at the bottom of the burner pot, if the burner isn't reaching the high temperature this type of fuel needs to vaporize, the fuel will not burn off causing a good puddle of fuel. Once the burner does reach temperature, the abundance of fuel will start to burn causing the heater to overheat, which can cause damage to the heater.

16. Maintenance

Fuel Maintenance Checklist (CHECK ONCE A YEAR)

- 1) Disconnect the fuel inlet line from the valve and place into a bucket. Turn on your pump or open your gravity feed valve to ensure there is a constant flow of fuel. This will indicate your fuel filter and fuel pump are operating correctly.
- 2) Remove the fuel inlet fitting from the valve and clean the screen behind.
- 3) Replace fuel inlet line to the fuel inlet fitting. Disconnect the fuel outlet line and place a cup or small container underneath the valve.
- 4) Turn the valve on to setting #1 and measure the fuel drip from the fuel outlet of the valve. It should measure 1 teaspoon per 50-60 seconds. This will indicate that the valve is working correctly.
- 5) Before re-connecting the fuel line, put some paper towel inside the burner pot and blow into the fuel line so if any dirt is in there, it will blow into the burner onto the paper towel.
- 6) Re-connect the fuel line to the fuel outlet on the valve and wipe the inside of the burner clean with the paper towel.

Cleaning the Burner

Carbon accumulates in the burner over a period of time and it must be cleaned out or the air cannot get into the burner and the heater will not operate correctly. It is especially important to ensure the air holes are clear.

If you are burning good quality fuel and the heater is burning efficiently above the top burner ring this cleaning procedure will only be required once a year. If there is rapid carbon build up in the burner pot, it indicates the heater is not being operated correctly or the need for a barometric damper adjustment. If you do not have a barometric you should install one to reduce the air in the burner that is causing the carbon build up. This must be rectified for satisfactory operation of the heater.

- 1) Open the door and remove the burner ring and the superheater
- 2) Insert the reamer tool provided into the fuel inlet hole. This will prevent loose carbon from falling into the fuel inlet during cleaning.
- 3) With a wire brush, scrape any loose carbon from the sides of the burner.

- 4) Using a paperclip, poke out the four rows of twelve air intake holes on the sides of the burner to ensure they are clear of any soot.
- 5) Remove any loose carbon from the base of the burner.
- 6) Remove the reamer tool and replace burner ring and the superheater.

Cleaning the Fuel Line

Any blockage in the fuel line from the oil-metering valve to the burner can be cleaned by removing the clean-out plug situated directly under the burner. The fuel lines themselves can be cleaned with compressed air or a pipe cleaner or even blowing air through to remove any blockages. The plug then must be replaced with tape sealant and checked for leaks. Tap the fuel line once re-connected to clear any air locks.

Exterior Surface

Little maintenance is needed for stainless steel. There are many stainless steel cleaners available and these may be applied as needed. An abrasive scotch bright pad can be used to remove burn discoloration or surface scratches by rubbing parallel to the grain of the brushed metal.

Replacement Parts

*Replacement Valve: Newport & Alaska- part# 02-011, Antarctic- part# 02-000, Lofoten- part# 02-019

*Replacement Fan: Newport & Alaska- part# 01-031, Antarctic & Lofoten- part# 01-030

*Replacement 12v Fan Speed Control: Newport, Alaska, Antarctic & Lofoten: part# 01-072

*Replacement 6" Burner & Components for all models: Burner Ring: part# 03-040, Superheater: part# 03-060, Burner: part# 03-010

*For replacement parts not shown here please e-mail us for more information. info@dickinsonmarine.com

17. Trouble Shooting

***Flames are burning incorrectly inside the burner pot-** The flames are burning too lean, this is to say too much air and/or not enough fuel. Reduce the air intake first by adjusting the barometric damper flap open to 3/8". This will keep the draft in the chimney strong but reduce the amount of air being drawn into the burner. Turn the fan off. If flames still below the top burner ring then start adding more fuel until ALL the flames are above the ring Pg 22 & 23.

***There is hard carbon build-up inside the burner-** This is also caused by burning the flames in the burner below the top ring. The burner needs a little more fuel and a little less air Pg 22 & 23.

***Flames are orange and dirty creating soot on the window & deck-** The flames are burning too rich, this to say too much fuel and / or not enough air. Add air first by turning the fan on. Just add enough air to turn the flames vibrant yellow and not lazy orange with black tips, however adding too much air will burn off the fuel and the flames will end up below the top burner ring. After a short time you will get to know what positions to set the fuel and air to maintain the most heat with the cleanest flames Pg 24.

***Burner flooded with fuel-** Is caused by fuel entering the burner faster than it is burning and is caused by increasing the fuel supply too quickly without the use of the combustion assist fan. Poor draft and/or ventilation Pg 25.

***Fuel is leaking out the overflow or the top of the valve-** The overflow line may have an air lock causing the excess fuel to back up into the valve, or excessive pressure going into the valve Pg 13.

***Fuel isn't getting to the burner-** The fuel line may be plugged from the valve to the burner. Disconnect the fuel outlet from the bottom of the valve and let the valve drip fuel into a small container or cup. Next blow hard through the fuel line so any debris will end up in the burner, then reconnect. If the valve was dripping fuel and the fuel line is not plugged tap the copper line to remove any air lock Pg 31.

***I am getting downdraft down my chimney pipe-** The smell of diesel or smoke coming into the boat may be caused by negative ventilation Pg 5-7.

The chimney may not be getting hot enough to create a strong draft Pg 5-7. Turn the fan on to a very slow speed but balance the fuel to keep flames above the ring Pg 18. Adjust the barometric flap so it is open between ¼ to 3/8 Pg 9.

***There was an explosion inside my heater-**This is caused by a downdraft however the air is sucked in by a negative draft that actually blows out the flames but is hot enough to re-ignite the hot vapor. Follow instructions for downdraft Pg 5-7.

***My valve is turned to the OFF position and oil is still going to the burner-** This is a broken O ring in the valve. See diagram Pg 29.

***** Low Sulfur Diesel Fuel Baffle maybe needed if using low sulfur diesel.**

Low sulfur and Ultra Low diesel is now being used in many places and depending on the heater and the chimney configuration, the fuel may be burning differently than it did before or does usually.

Please perform all troubleshooting before assuming it is a low sulfur fuel issue. A burner baffle is available or included with your heater, that retains heat in the combustion chamber and will speed up the vaporization of these new types of diesel fuels. The baffle is placed on top of the burner edge. Use the draft assist fan more as the fan is needed more to burn off the new type of fuel.

Indications of Low or Ultra Low Sulfur Fuel In-complete Burn

- The flames burn below the top burner ring inside the burner pot.
- Turning up the fuel flow from the valve makes no change to the flames.
- It takes a long time for the flames to go out when the valve is shut off.
- Followed all troubleshooting and still having issues with getting heat.
- Excessive hard carbon in the bottom of the burner

The low sulfur fuel requires a little more air, so keep the flames as vibrant as possible. You will soon find what fan settings are best. Do not to use too much air so the flames will fall back into the burner, and create the hard carbon.

There is no way to tell what type of fuel you may have, low sulfur and ultra low sulfur diesel is a yellow-green or a red-brown color.

Make sure to keep a close eye at the fuel accumulation at the bottom of the burner pot, if the burner isn't reaching the high temperature this type of fuel needs to vaporize, the fuel will not burn off causing a good puddle of fuel. Once the burner does reach temperature, the abundance of fuel will start to burn causing the heater to overheat, which can cause damage to the heater.

18. Warranty Policy

We at Dickinson wish to maintain a reasonable and easy system for returns, warranty, returns and exchanges. To accomplish this, we would like to inform you of some helpful guidelines and procedures to use and follow when sending back product to the Dickinson Marine. All correspondence regarding returns, warranties and exchanges will go through the factory of Dickinson Marine in Surrey, BC, Canada and the product MUST be returned to this location.

Warranty

Dickinson Marine warranties all of its products for a period of one year dated from the purchase of the product by the end user with proof of purchase or a registered warranty. We warrant our barbeque burners for a period of 3 years dated from the purchase of the product by the end user with a registered warranty. The warranty card should be copied for your records and returned to Dickinson to activate your warranty within 90 days of your purchase. You can also activate it online at www.dickinsonmarine.com A copy of the warranty card must have been received or a proof of purchase must be presented to receive the warranty.

1. The customer can contact us directly to settle any warranty issues. We are pleased to help. Call us toll free 1-800-659-9768 or email: info@dickinsonmarine.com
2. If the customer is returning a complete product they see as defective, be sure the product has been assembled correctly and is being used correctly. If you are not sure please call our Technical Help Department @ 1-800-659-9768. Dickinson Marine will not provide

- credit for used products that are not defective. In these cases, it is best to call the factory to determine if the product is being used correctly, has been assembled correctly or is in fact defective.
3. All products being sent back to Dickinson Marine must have a Return Authorization Number. Contact us at Dickinson Marine toll free 1-800-659-9768 or e-mail info@dickinsonmarine.com to obtain a Return Authorization Number. This allows us to track and process your return. Once you have received an RA# from us, include your proof of purchase and ship to the address below. We recommend you ship using the mail service insured and retain a tracking number. Customers are responsible for the shipping costs for all returns and exchanges.

Dickinson Marine Returns
Unit# 101-17728 66 Ave
Surrey, BC
V3S 7X1, Canada

4. Products that are demonstrably older than the warranty period or those that have obviously been misused will not be returned, exchanged, or repaired.

Non-defective Returns & Exchanges

Dickinson reserves the right to apply a 20% restocking fee for returned product sent back. An RA # will be needed from the factory to facilitate any return. Credits will be made at the last purchased price for that part number.

Limited Warranty

WARRANTY PROVISIONS: Dickinson warrants this product to be free of defects in workmanship and materials for a period of one year. This warranty is limited to claims submitted in writing within a one-year period following the date of purchase. If any part of your new product fails because of a manufacturing defect within the warranty period Dickinson offers to replace said parts free of charge, provided, however, that such parts have not been improperly repaired, altered or tampered with or subjected to misuse, abuse or exposed to corrosive conditions. This warranty, however, is limited by certain exclusions, time limits and exceptions as listed below. Read these limitations and exclusions carefully.

TIME LIMIT: This warranty is given too and covers only the original purchaser. Coverage terminates one year from the date of purchase for parts replacement.

EXCLUSIONS : This warranty does not cover or include : (a) Any normal deterioration of the product and appearance of items, due to wear and/or exposure; (b) any guarantees, promises, representations, warranties or service agreements given or made by an authorized distributor or other person selling this product, other than those specifically stated herein; (c) any damage or defect due to accident, improper repair, alteration, unreasonable use including failure to provide reasonable and necessary maintenance, misuse or abuse of the equipment, or exposure to corrosive conditions. This warranty is conditioned upon normal use, reasonable and necessary maintenance and service of your product, and written notice being given promptly upon Buyer's discovery of a warranty claim, pursuant to paragraph 6 below. Reasonable and necessary maintenance is maintenance which you are expected to do yourself or have done for you. It is maintenance, which is necessary to keep your product performing its intended function and operating at a reasonable level of performance.

DAMAGE LIMITATION WARNING : IN NO EVENT SHALL Dickinson BE LIABLE FOR ANY INCIDENTAL OR CONSEQUENTIAL DAMAGES, INCLUDING (BUT NOT LIMITED TO) LOSS OF USE OF THE PRODUCT, LOSS OF TIME, INCONVENIENCE, EXPENSES FOR TRAVEL, LODGING TRANSPORTATION CHARGES, LOSS BY DAMAGE TO PERSONAL PROPERTY OR LOSS OF INCOME, PROFITS OR REVENUE.

ORAL OR IMPLIED WARRANTY LIMITATIONS: The foregoing warranty is exclusive and in lieu of all other warranties, written or oral, expressed or implied, including but not limited to any warranty or merchantability or fitness for a particular purpose.

TRANSFER LIMITATIONS: This warranty is not assignable or transferable. It covers only the original purchaser.

CLAIM PROCEDURE: In the event of a defect, problem or that a breach of this warranty is discovered, in order to protect any warranty rights you must promptly notify Dickinson. Give name, address, and model name, location of unit, description of problem and where you can be reached during business hours.

RESERVED RIGHT TO CHANGE: Dickinson reserves the right to make changes or improvements to products it produces in the future without imposing on itself any obligations to install the same improvements in the products it has previously manufactured.

SECOND OR SUBSEQUENT OWNER: Dickinson does not give any warranty to secondary or subsequent purchasers, and it disclaims all implied warranties to such owners.

INSPECTION: To assist you in avoiding problems with your product and to validate this warranty you are required to do the following: (a) read the warranty; (b) inspect the product. Do not accept delivery until you have examined the product with your supplier; (c) ask questions about anything you do not understand concerning the product.

OWNER REGISTRATION: Fill out the WARRANTY CARD within 30 days from the date of delivery. **WARRANTY: RETURN OF THE CARD IS CONDITION PRECEDENT TO WARRANTY COVERAGE AND PERFORMANCE. IF YOU DO NOT FILL OUT AND MAIL THE CARD AS DIRECTED, YOU WILL NOT HAVE A WARRANTY.**

19. Register your Warranty.....

Please register your warranty with Dickinson Marine. Fill out and send back the warranty registration below. Make sure to include the serial # for our records.

No warranty will be extended for improper installations. Use of any unapproved materials, equipment, or installation procedures will result in a voided warranty. Do not use any substitutes of the heaters valve, burner or fan other then the ones supplied by Dickinson. Dickinson Marine accepts no liability for any damage or loss of service resulting from unapproved modifications.

Warranty Form

I have read and understand the Limited Warranty and the entire Instruction Manual and agree to the terms and conditions. (PLEASE PRINT)

Name: _____

Address: _____

Phone: _____

Heater Model Name: _____

Heater Serial #: _____

Date of Purchase: _____

Seller's Name: _____

Seller's Location: _____

Signature: _____

This warranty form can also be filled out online.

www.dickinsonmarine.com

Dickinson Marine

#101-17728 66 Avenue, Surrey, BC

V3S 7X1 Canada

Tel: 604-574-8641

Fax: 604-574-8659

E-mail: info@dickinsonmarine.com

Website: www.dickinsonmarine.com

All rights reserved. No part of this manual may be reproduced without permission in writing from Dickinson Marine. Dickinson also reserves the right to modify or change without notice, any materials, applications, equipment, accessories, and/or prices. All measurements and weights are approximate.