

Night Owl Optics®

NIGHT VISION

NOCX3

Monocular

OWNERS MANUAL

Please Read

Excessive exposure to bright light, with power on, will destroy internal Image Intensifier Tube.

Night Vision device is designed for nighttime use only.

Not for use in daylight conditions nor in lighted environments.

Keep lens cap on device when not in use to protect optics and internal Image Intensifier Tube.

CAUTION: Do not point Infrared Emitter directly into eye at close range.

Keep out of reach of children.

The infrared emitter emits a BRIGHT, although invisible, beam of light. As with any bright light, do not point into the eye.

Quick Start

GET FAMILIAR WITH THE DEVICE HOW TO FOCUS YOUR NIGHT VISION DEVICE

In a **LIGHTED** environment:

- Step 1** Install Batteries.
- Step 2** DO NOT REMOVE the LENS CAP.
The pinhole in the lens cap lets through a small amount of light.
Removing lens cap in daylight could damage the unit.
- Step 3** Rotate both EYEPIECE and OBJECTIVE LENS clockwise until they stop.
- Step 4** Press POWER button to turn device on.
Lens cap should still be installed on the device.
- Step 5** Look through the EYEPIECE.
Look at an object across the room, and rotate EYEPIECE until object comes into focus.

Important: In LIGHTED conditions,

Rotating OBJECTIVE LENS, with lens cap on, will not effect focus or clarity of image. Do not rotate OBJECTIVE LENS yet.

Activating INFRARED has no effect on image.

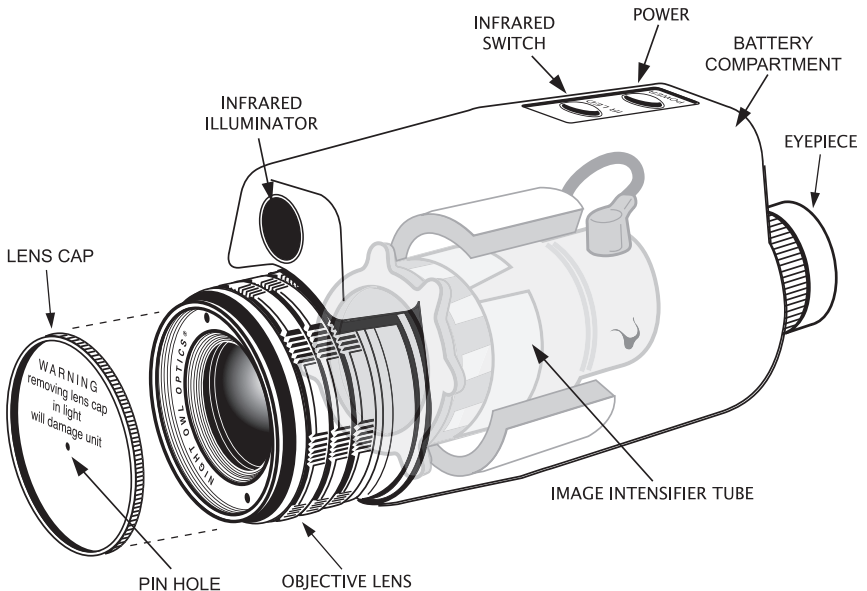

In a DARK environment:

Step 6 In the dark, remove LENS CAP.

Step 7 Do NOT rotate EYEPIECE. Rotate OBJECTIVE LENS until objects come into focus.

You have already adjusted the EYEPIECE to your individual eyesight.
Rotate the OBJECTIVE LENS to focus on objects at varying distances.

Step 8 Click on the INFRARED button.

A beam of infrared light, invisible to the human and animal eye, provides extra illumination.

Warning:

When the power is turned OFF, the image will not immediately disappear. It will remain visible for up to several minutes as the tube discharges. The discharge (fading of image) will be faster in higher light environments, slower in the dark.

**For technical assistance, call our customer service line at 1-800-444-5994.
If you have any problem, call before returning the product to the store where purchased.**

Image Quality

The image you see through a Night Vision device is VERY DIFFERENT from the image observed using day-time monoculars. A Night Vision image is electronically amplified and then reproduced on a phosphorus screen and therefore not as "clear" as a day-time monocular image.

Light and dark marks (spots) caused by the Electronic Intensifier Tube can be seen in the field of view. These are normal and are not defects in the Electronic Intensifier Tube.

Image sharpness is also not consistent across the field of view. The image has very high resolution in the center. The image becomes more distorted toward the periphery of the image. Due to our sophisticated corrective optics, the amount of distortion in your Night Vision device is less than the distortion found in other Night Vision devices.

IMPORTANT:

You may see spots or other anomalies on the image when testing in a lighted environment with the lens cap on.

When using the device in the field with the lens caps removed, many of these anomalies will disappear. Testing indoors, with the lens caps affixed, focuses the light into a narrow beam through the center of the image intensifier tube; this causes light to reflect inside the device to produce spots on the phosphorus screen that many times will not be visible in the field.

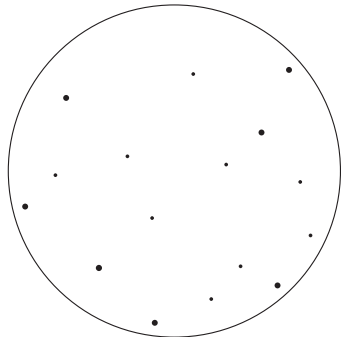

Typical Image Appearance

Use of the Infrared Illuminator in a closed room, or at close range, will exaggerate the light and dark spots on the Electronic Intensifier Tube. The Infrared Illuminator, although invisible to human and animal eyes, is very bright at close range when viewed through the device. This bright light exaggerates the spots on the Electronic Intensifier Tube. Testing your Night Vision device indoors with the Infrared Illuminator, at close range, is not representative of the performance of the device in its intended outdoor application.

Frequently Asked Questions

Why are the projected images always green using Night Vision technology?

Night Vision phosphor screen is purposefully engineered because the human eye can differentiate more shades of green than other colors.

Why do you focus both the front (Objective lens) and Eyepiece (Ocular)?

You do not see through the Night Vision device, like a day monocular. Rather you see the phosphor screen on the back of the tube. The objective lens focuses the image on to the front of the intensifier tube. That image is then converted into electrons. The electrons strike the phosphorous screen converting electrical energy into a visible image. The eyepiece focuses your vision on to the image on the phosphorous screen.

What is the effective range of Night Vision?

Maximum range is up to 700 ft. depending on the model. The maximum viewing distance depends on the environmental conditions. Overcast conditions, fog or rain will reduce the effective distance you can see. The Infrared Illuminator will increase viewing range, especially in areas of complete darkness where there is no ambient light.

What is the maximum effective distance of the Infrared Illuminator?

75 to 125 yds. The farther the object, the less intense the infrared light will be on the target.

Are Night Vision devices safe?

Night Vision products include shield-encased image intensifiers. The infrared illuminator utilizes light emitting diodes (LED's) operating in the infrared range and will not harm your eyes like a laser.

Recognize that the image produced on the phosphorous screen can be very bright. Staring into a very bright light causes the pupil to constrict. Your eye needs time to adjust to ambient light.

When can I expose the unit to light?

For demonstration purposes there is a pinhole in the lens cap, which enables you to power on the unit in the light. The lens cap can be taken off during daylight, but the unit has to be off.

What is Generation 1? How does it differ from other Generations of Night Vision devices?

Generation 1, 2, 3 and 4 all employ electron bombardment technology. All of these technologies convert light into electrons and reproduce the image on a phosphorous screen.

Generation 1 produces a higher resolution image than Generation 2.

Generation 3 and 4 are used by the United States Military and are very expensive.

Generation 2, 3 and 4 use a fiber optic device and/or special chemicals to further amplify light.

Performance under Various Light Conditions

Complete Darkness

Your Night Vision device works by amplifying available natural light. In complete darkness, with no available natural light, you cannot see without the use of the Infrared Illuminator (IR). The IR works like a flashlight, but is invisible to human and animal eyes.

Half-Moon

A half-moon provides a substantial amount of ambient light to be amplified by the internal Electronic Intensifier Tube. Without the assistance of the IR, you can recognize a man-sized object about 100 yards away.

Starlight

A Starlight provides the minimal amount of ambient light to allow viewing unassisted by the IR. The IR will greatly improve target recognition.

Urban Environment (with man-made light sources)

Streetlights and headlights will generally not damage the Electronic Intensifier Tube, if a safe distance away. As a precaution, do not point the device directly into a light source. At a distance of more than 30 yards, most common man-made light sources will generally not damage the device.

Troubleshooting

Unit may require several seconds after power-on for image to appear. This is normal.

Focus Problems

Try in lighted environment with lens cap on.

Are you able to focus the eyepiece?

- YES - Use in dark with lens cap off but do not rotate eyepiece.
- NO - Call our Customer Service Line

Unit does not turn on.

Light does not illuminate when button is pressed.

- Check to see if batteries are installed correctly
- No batteries
- Dead batteries
- Power light on, but no image
- Unit could be defective, call our Customer Service Line

Image is too dark

- Use the Infrared (IR) Illuminator
- Take off the lens cap

Projected image is dim.

- Batteries are low – insert new batteries

How Night Vision Works

Light coming into the device from the direction of the object is gathered by the objective lens and focused onto the Image Intensifier Tube.

The front of the Image Intensifier Tube contains a photocathode which converts light into electrons.

The device contains a very high voltage power supply, which converts the 3 volts supplied by the batteries into 17 kilovolts.

The high voltage hurls the electrons into the phosphorous screen. The phosphorous screen illuminates with an image when struck by electrons. The eyepiece optic then focuses the phosphorous screen image to your eye.

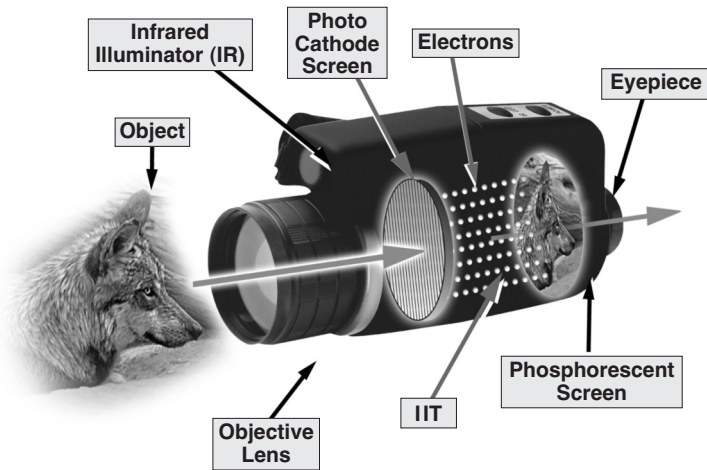

How to Care for your Night Vision Device

If you intend to store your unit for more than 24 hours, it is best to remove the batteries.

Keep the unit in a cool, dry place.

Clean lenses the same way you would your camera, with professional lens cleaning supplies.

The lenses are optically coated and may be scratched if abrasive material is used or if dirt is rubbed into the glass. Do not touch lens surface with fingers.

Do not drop or expose to shock. The Intensifier Tube is made of glass.

Do not disassemble or attempt to service the device. The power supply generates 17,000 volts inside!

If your device needs repair, please refer to your warranty card.

Do not leave inside car on a hot, sunny day.

Clean exterior with a soft, clean cloth.

If condensation is visible on the unit, return it to a normal temperature and wait until the condensation disappears before using.



Product Specifications

	NOCX3
GENERATION	1
MAGNIFICATION	3.1X
RANGE OF VIEW	583 ft. 175 m
POWER SUPPLY	3V Lith (123)
WEIGHT	16 oz. 454 g
DIMENSIONS	7.2x2.3 x3.2 in 183x58x81 m
OBJECTIVE LENS	
FOCAL LENGTH	50 mm
APERATURE	1:1.2
FOV@1000 YDS	628 ft. 191 m
FOCUSING RANGE	4 ft. + 1.2 m +
TRI-POD MOUNT	NO

Night Owl Optics[®]

NIGHT VISION

1465 Henry Brennan
El Paso, Texas 79936
1-800-444-5994
www.nightowloptics.com