

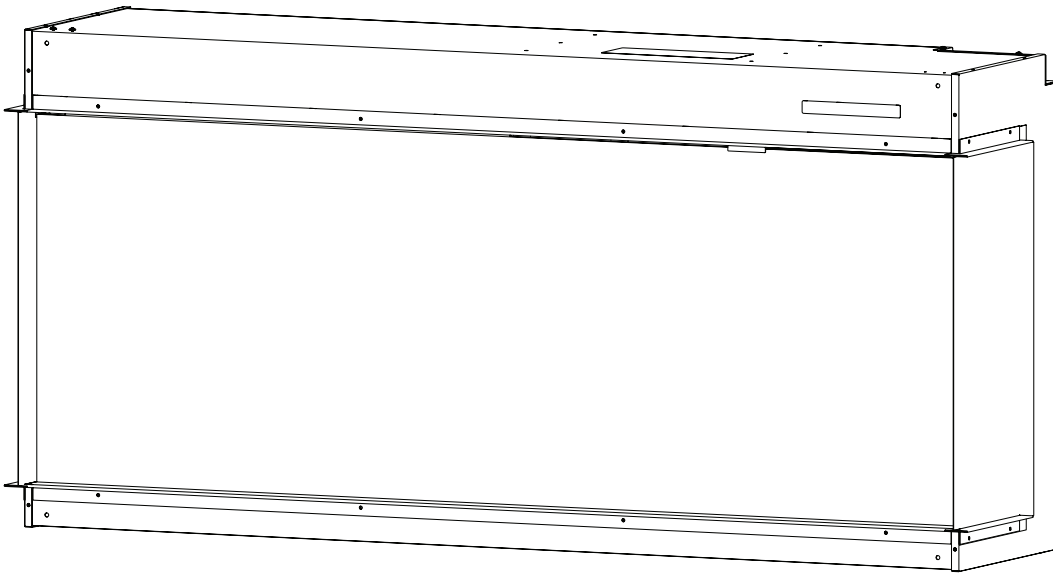

Service Manual

Models

XLF5017-XD - 6911580000
XLF6017-XD - 6911590000
XLF7417-XD - 6911600000
XLF8817-XD - 6911610000
XLF10017-XD - 6911620000



IMPORTANT SAFETY INFORMATION:

Read this manual first before attempting to install or use this electric fireplace. Always comply with the warnings and safety instructions contained in this manual to prevent personal injury or property damage.

Table of Contents

Exploded Parts Diagrams	3
XLF5017-XD Replacement Parts List	3
XLF6017-XD Replacement Parts List	4
XLF7417-XD Replacement Parts List	5
XLF8817-XD Replacement Parts List	6
XLF10017-XD Replacement Parts List	7
Wiring Diagrams	8
XLF5017-XD	8
XLF6017-XD	8
XLF7417-XD	9
XLF8817-XD	9
XLF10017-XD	9
Replacement Part Procedures	10
Preparing the Firebox for Service	10
Heater Assembly Replacement	11
Main Control Board Replacement	12
Power Supply Replacement	13
Relay Board Replacement	14
Adapter Board Replacement (XLF8817-XD & XLF10017-XD)	14
Hidden Touch Controls Replacement	15
Temperature Sensor (NTC) Replacement	16
Flicker Motor Replacement	17
Flame LED Replacement	18
Media Bed LED Replacement	19
Overhead LED Replacement	20
Troubleshooting	21
App	22

Conventions used in this manual:

! **NOTE:** Procedures and techniques that are considered important enough to emphasize.

 **CAUTION:** Procedures and techniques which, if not carefully followed, will result in damage to the equipment.

 **WARNING:** Procedures and techniques which, if not carefully followed, will expose the user to the risk of fire, serious injury, or death.

Exploded Parts Diagrams

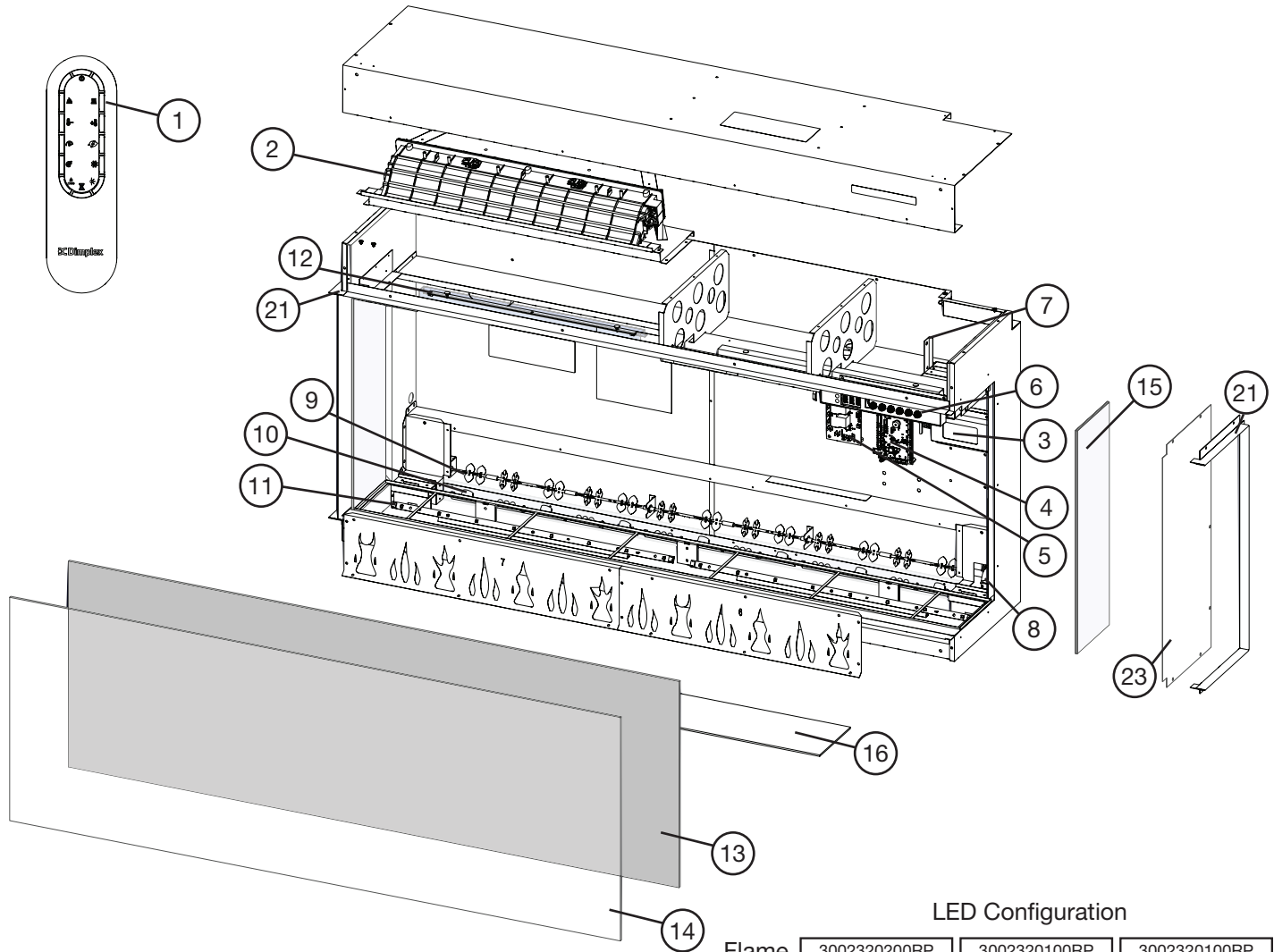

LED Configuration		
Flame	3002320200RP	3002320100RP
Media	3002350300RP	3002350300RP
Overhead	3002350200RP	3002350200RP

XLF5017-XD Replacement Parts List

1. Remote Control	X-3002310100RP	13. Mirrored Glass	X-5903780100RP
2. Heater Assembly	X-2203860100RP	14. Front Glass	X-5903760100RP
3. Power Supply	X-2100250500RP	15. Side glass (includes 1)	X-5903770100RP
4. Main Control Board	500002258	16. Media Tray	X-5903790100RP
5. Relay Board	500002277	17. Medium Acrylic Crystals	X-1400150300RP
6. Hidden Touch Controls	500002274		(2 required)
7. Temperature Sensor (NTC)	X-3001560600RP	18. Large Acrylic Crystals	X-1400130500RP
8. Flicker Motor	X-2000550100RP	19. Extra-large Acrylic Crystals	X-1400170300RP
9. Flicker Rod	X-5903960100RP	20. Driftwood	X-0478800100RP
10. Flame LED Strip (2)	X-3002320100RP	21. Trim Assembly	X-1037390100RP
(1)	X-3002320200RP	22. Hardware Kit	X-9602620400RP
11. Media LED Strip (2)	X-3002350300RP	23. Side Panel (includes 1)	X-1033820100RP
12. Overhead LED Strip (2)	X-3002350200RP		

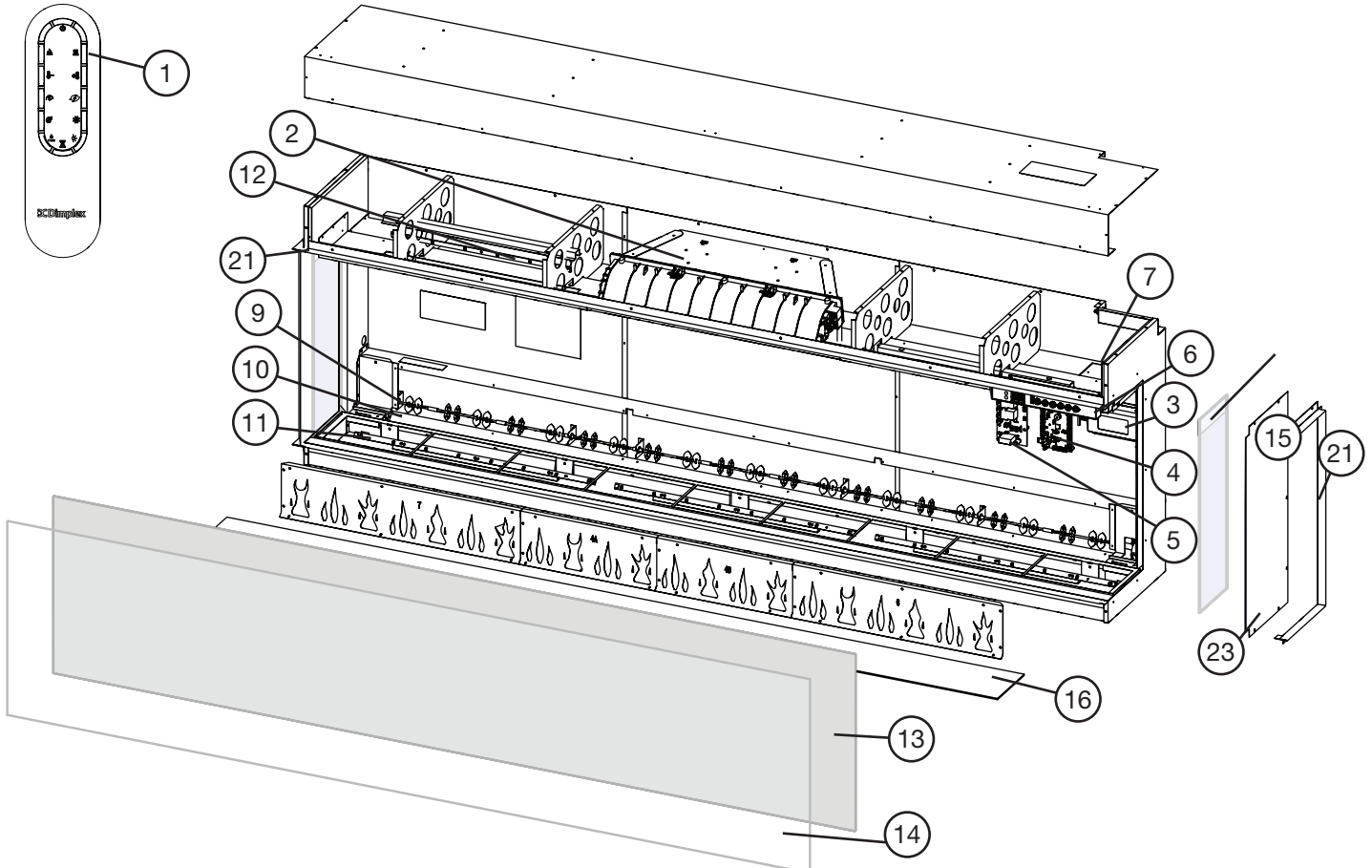

LED Configuration

Flame	3002320200RP	3002320100RP	3002320300RP	3002320300RP
Media	3002350300RP	3002350300RP	3002350300RP	
Overhead	3002350200RP	3002350200RP	3002350200RP	

XLF7417-XD Replacement Parts List

1. Remote Control	X-3002310100RP	13. Mirrored Glass	X-5903780300RP
2. Heater Assembly	X-2203860100RP	14. Front Glass	X-5903760300RP
3. Power Supply	X-2100250500RP	15. Side glass (includes 1)	X-5903770100RP
4. Main Control Board	500002258	16. Media Tray	X-5903790300RP
5. Relay Board	500002277	17. Medium Acrylic Crystals	X-1400150300RP
6. Hidden Touch Controls	500002276		(3 required)
7. Temperature Sensor (NTC)	X-3001560600RP	18. Large Acrylic Crystals	X-1400130700RP
8. Flicker Motor	X-2000550100RP	19. Extra-large Acrylic Crystals	X-1400170500RP
9. Flicker Rod	X-5903960300RP	20. Driftwood	X-0478800300RP
10. Flame LED Strip (1)	X-3002320100RP	21. Trim Assembly	X-1037390300RP
(1)	X-3002320200RP	22. Hardware Kit	X-9602620400RP
(2)	X-3002320300RP	23. Side Panel (includes 1)	X-1033820100RP
11. Media LED Strip (3)	X-3002350300RP		
12. Overhead LED Strip (3)	X-3002350200RP		

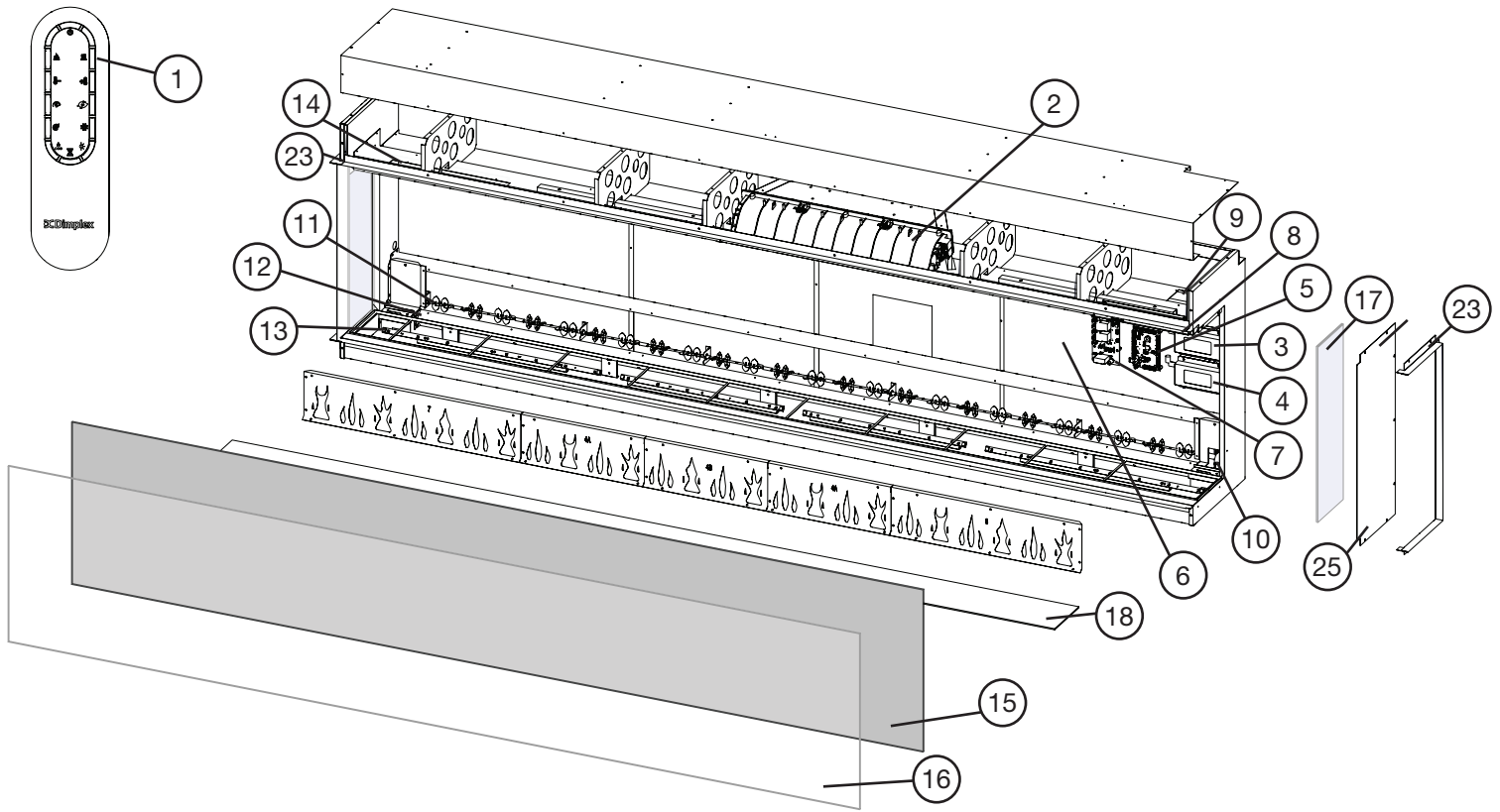

LED Configuration

Flame	3002320300RP	3002320300RP	3002320200RP	3002320100RP	3002320100RP
Media	3002350300RP	3002350300RP	3002350300RP	3002350300RP	3002350300RP
Overhead	3002350300RP	3002350200RP	3002350200RP	3002350300RP	3002350300RP

XLF8817-XD Replacement Parts List

1. Remote Control X-3002310100RP	13. Media LED Strip (2) X-3002350200RP
2. Heater Assembly X-2203860100RP	(2) X-3002350300RP
3. Power Supply (5 AMP) X-2100250500RP	14. Overhead LED Strip (1) X-3002350100RP
4. Power Supply (3 AMP) X-2100250600RP	(3) X-3002350200RP
5. Main Control Board 500002258	15. Mirrored Glass X-5903780400RP
6. Adapter Board X-3002400100RP	16. Front Glass X-5903760400RP
7. Relay Board 500002277	17. Side glass (includes 1) X-5903770100RP
8. Hidden Touch Controls 500002262	18. Media Tray X-5903790400RP
9. Temperature Sensor (NTC) X-3001560600RP	19. Medium Acrylic Crystals X-1400150300RP
10. Flicker Motor X-2000550100RP (4 required)
11. Flicker Rod X-5903960400RP	20. Large Acrylic Crystals X-1400130400RP
12. Flame LED Strip (2) X-3002320100RP	21. Extra-large Acrylic Crystals X-1400170600RP
(1) X-3002320200RP	22. Driftwood X-0478800400RP
(2) X-3002320300RP	23. Trim Assembly X-1037390400RP
	24. Hardware Kit X-9602620400RP
	25. Side Panel (includes 1) X-1033820100RP

Wiring Diagrams

XLF5017-XD

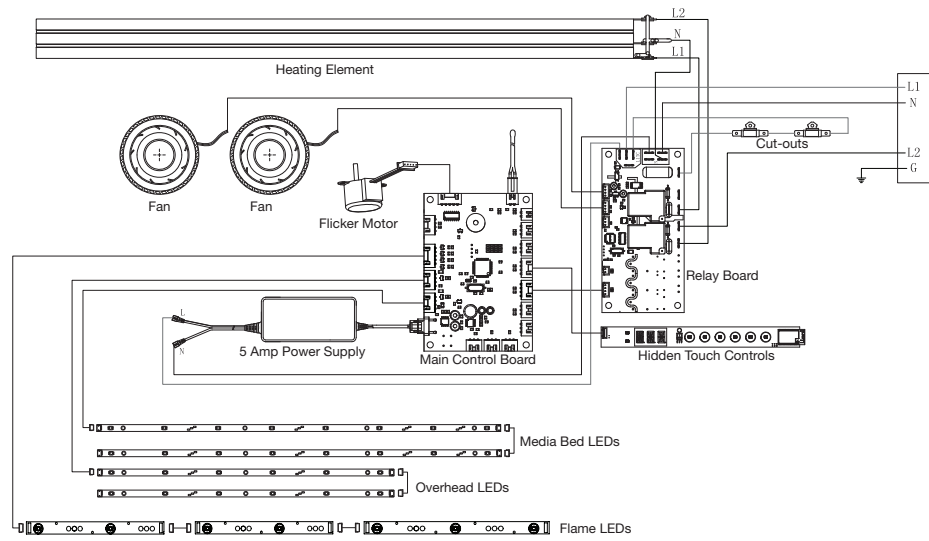

XLF6017-XD

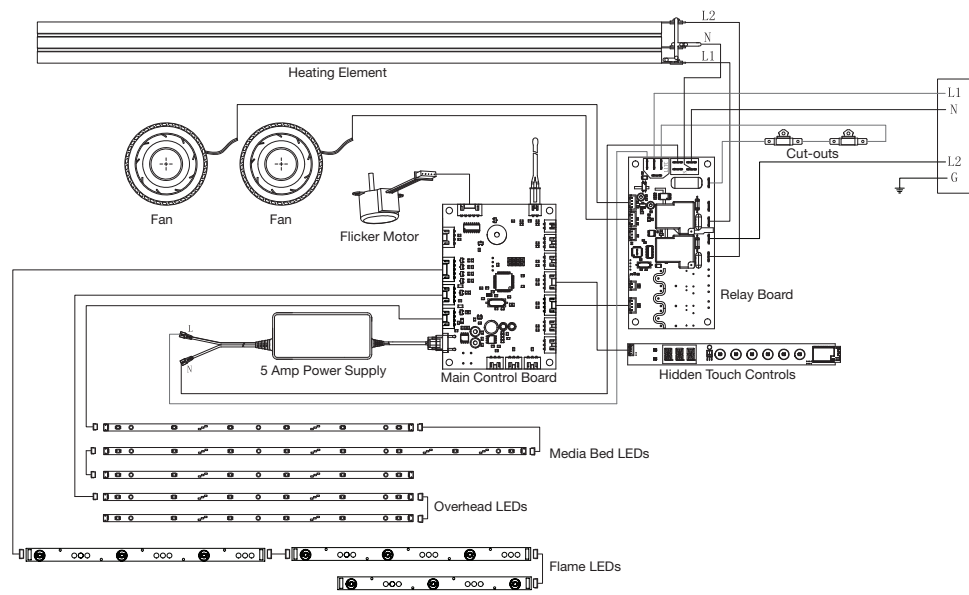

XLF7417-XD

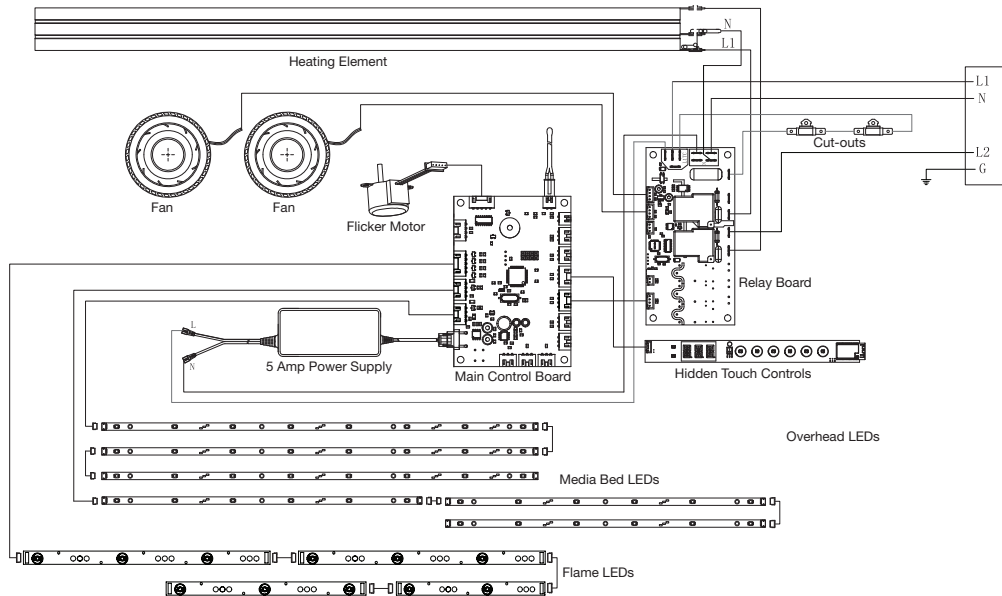

XLF8817-XD

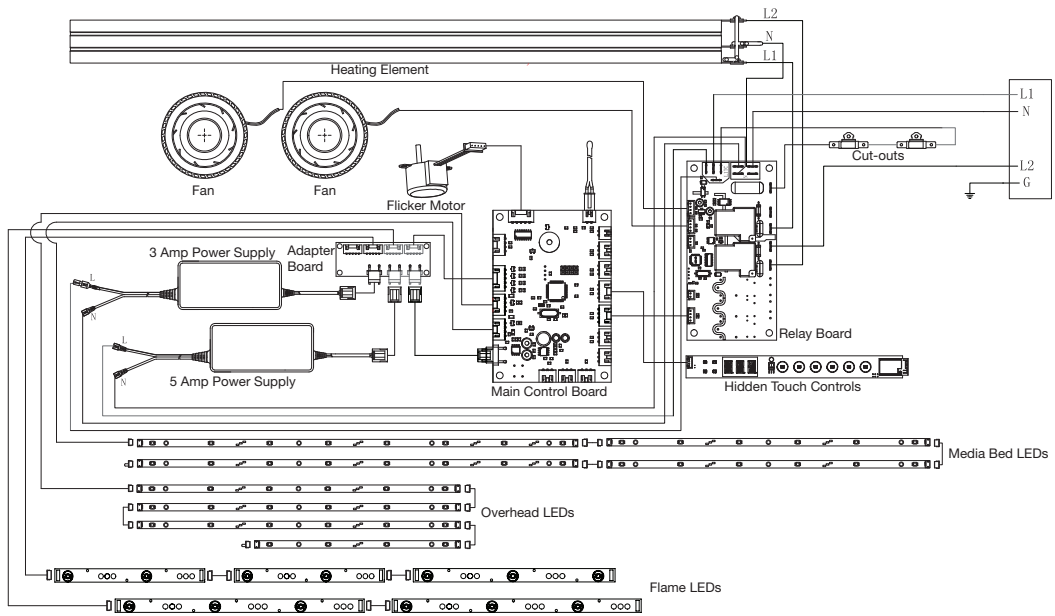

XLF10017-XD

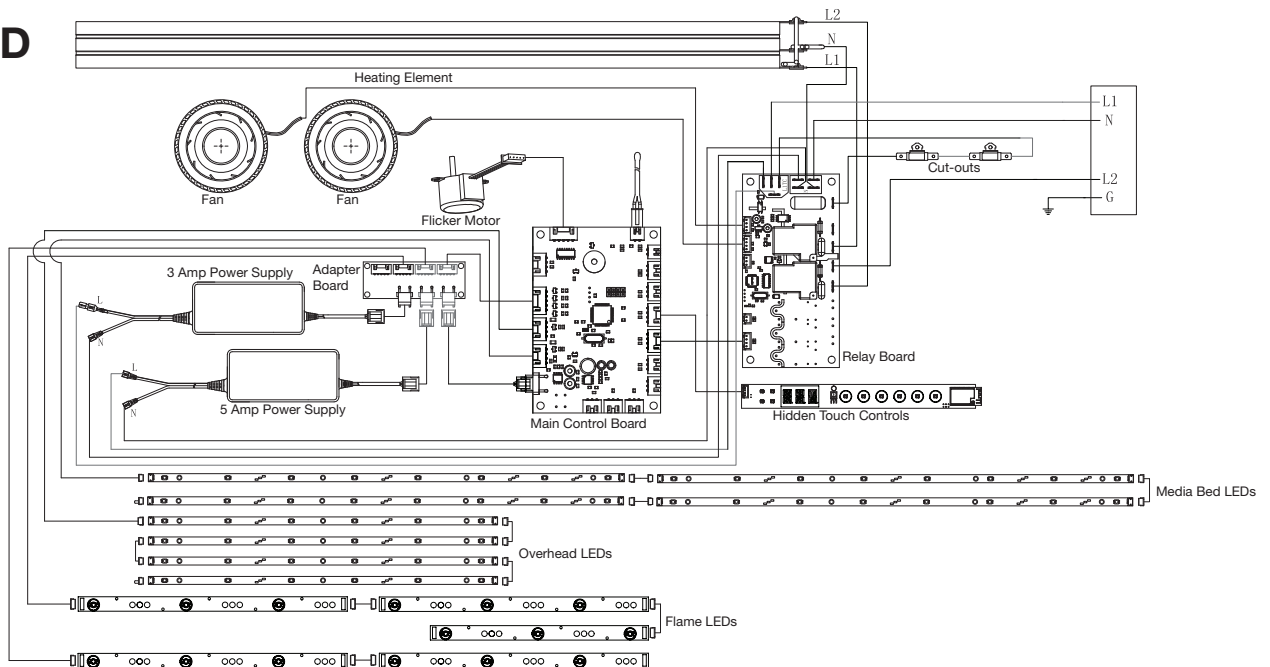

Replacement Part Procedures

Preparing the Firebox for Service

⚠ WARNING: If the firebox was operating prior to servicing, allow at least 10 minutes for the heating elements to cool off to avoid accidental burning of skin.

⚠ WARNING: Disconnect power before attempting any maintenance to reduce the risk of electric shock or injury to persons.

Tools Required: Phillips-Head Screwdriver
Suction Cup (to assist in lifting glass)

1. Remove front glass bracket(s) (Figure 1).
2. Tilt the front glass outward and lift to remove it (Figure 2). Set it in a safe place for the duration of the service.
3. For corner or bay installations, remove the slide glass by pushing it up and tilting it outward from the bottom.
4. Remove the media and put it aside for the duration of the service.
5. Remove the mirrored glass brackets (Figure 3).
6. Tilt the mirrored glass and lift to remove it (Figure 4).

Figure 1

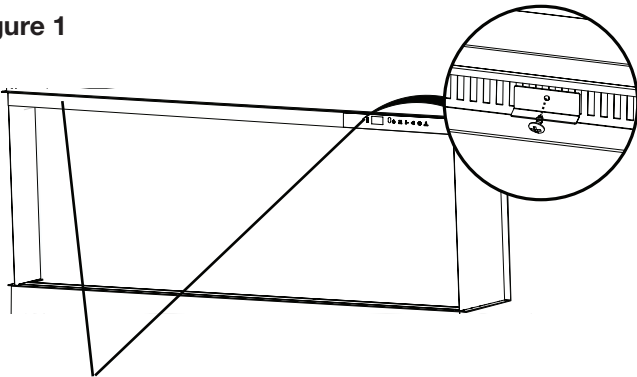

Front Glass Bracket(s) -
Quantity varies by model

Figure 2

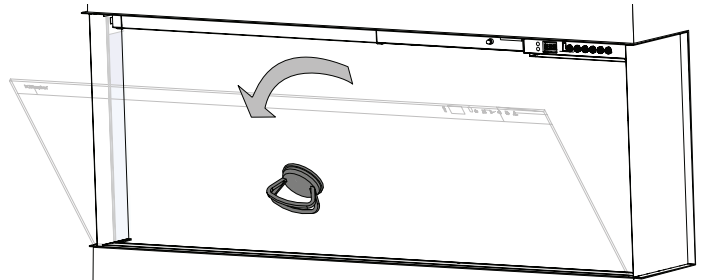
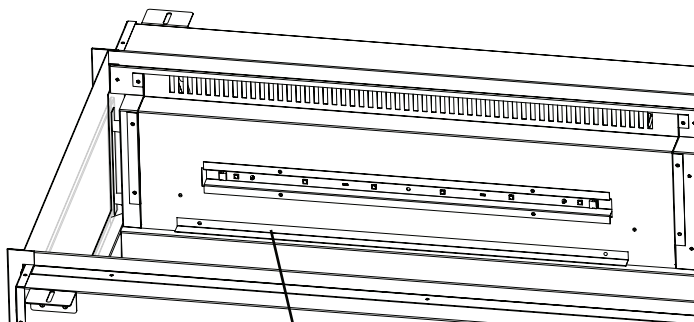
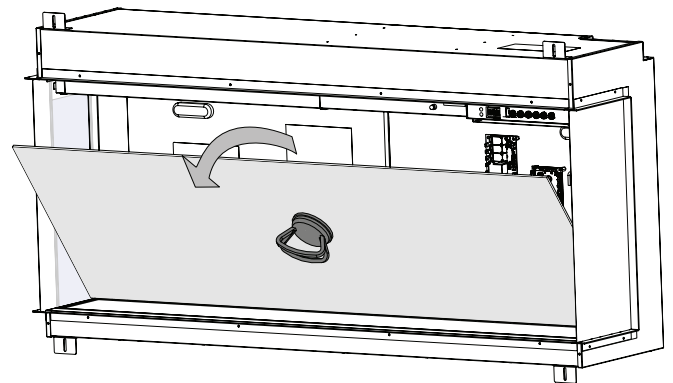

Figure 3



Mirrored Glass Bracket -
Quantity varies by model

Figure 4



Heater Assembly Replacement

Tools Required: Phillips-Head Screwdriver
Pliers

1. Follow the instructions for *Preparing Firebox for Service* on page 10.
2. Remove the 4 screws that secure the overhead LED assembly. Unplug the LED connection, and set the assembly aside (**Figure 5**).
3. Remove the 8 screws around the perimeter of the heater assembly panel (**Figure 5**).
4. Push the heater assembly toward the back of the fireplace. It will move about 1/2 inch.
5. Hold the heater assembly front edge and lower the heater assembly.
6. Trace the connections from the heater assembly to the relay board. Carefully disconnect the connections, noting their original locations. Cut any restrictive wire ties.
7. Remove the defective heater assembly.
8. Feed the wires, one at a time, from the new heater assembly through the top portion of the housing to make the connections on the relay board.
9. Connect the wires from the heater assembly to the correct locations on the relay board.
10. Secure the wires using the provided wire ties and ensure they are pushed back as to not be too close to the back of the mirrored glass.
11. Position the new heater assembly by aligning the back of the bracket in the top housing and tilting it upward. Ensure the LED wire is fed through the slot for the LED assembly
12. Pull the heater assembly forward to align the screw holes. Secure using the previously removed screws.
13. Connect the LED wire, ensuring the IN marking on the board is oriented toward the right side. Secure the LED assembly.

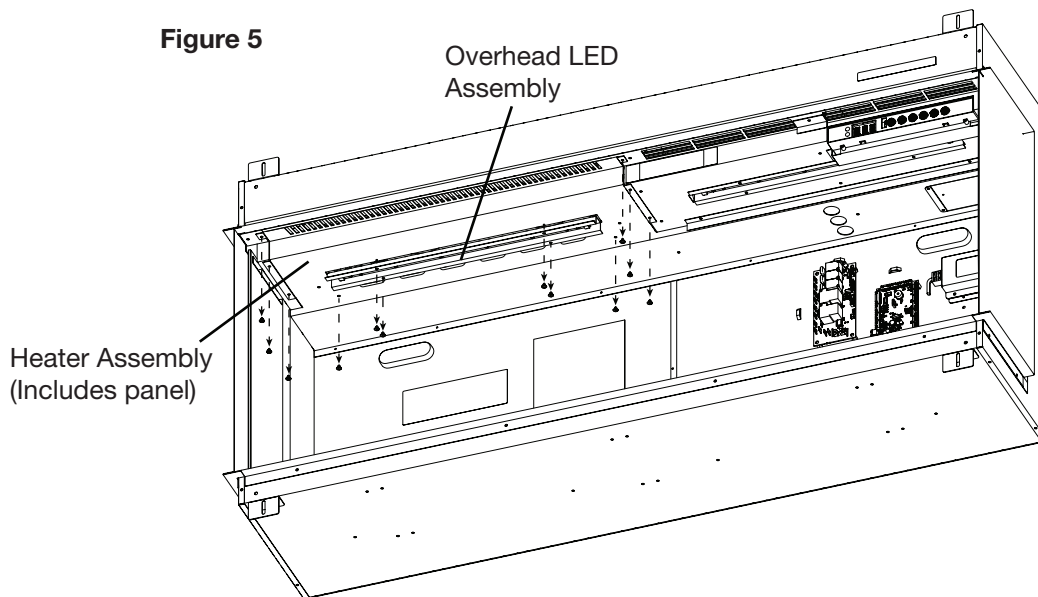

Main Control Board Replacement

Tools Required: Phillips-Head Screwdriver

1. Locate the jumper terminal on the new main control board and remove the jumper shown. (Figure 6)

⚠ CAUTION: The Heat Disable jumper should only be removed if a permanently heat-disabled installation is required. See owner's manual for more information.

2. Follow the instructions for *Preparing Firebox for Service* on page 10.

3. Remove the screw on each corner of the main control board (4 total) (Figure 7 / Figure 8).

4. Disconnect the wires from the main control board, noting their original locations.

5. Secure the new main control board using the previously removed screws.

6. Connect the wires on the new main control board in the correct locations.

7. Ensure wires are not too close to the mirrored glass.

8. Reassemble the firebox.

Figure 6

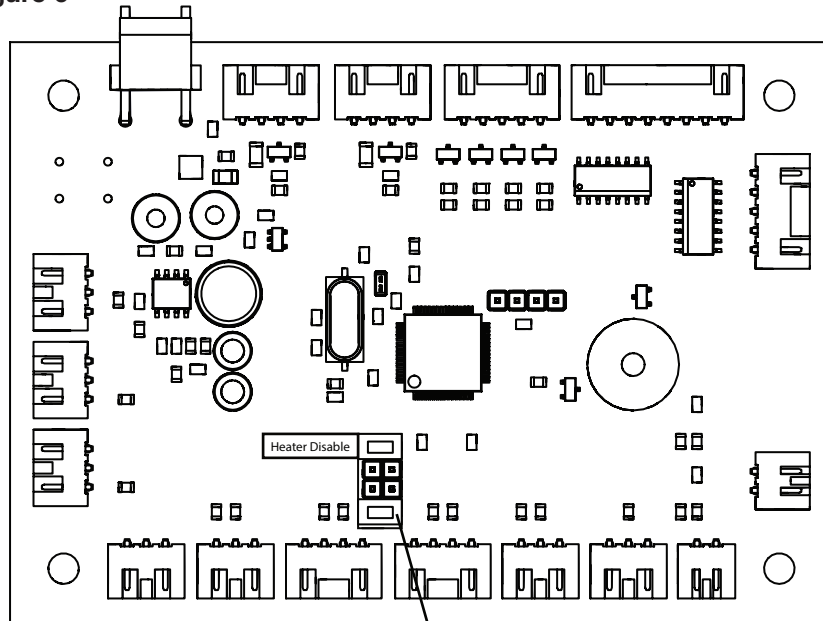

Remove this jumper

Power Supply Replacement

Tools Required: Phillips-Head Screwdriver

1. Follow the instructions for *Preparing Firebox for Service* on page 10.
2. Remove the 4 screws that secure the power supply bracket (**Figure 7 / Figure 8**).
3. Trace the wires from the defective power supply and disconnect the power supply connections from the main control board and relay board (and adaptor board, for XLF8817-XD and XLF10017-XD models), noting their original locations. Cut restrictive wire ties.
4. Position the new power supply and secure it using the power supply bracket.
5. Connect the new supply in the correct locations on the main control board and relay board.
6. Replace any wire ties that have been cut. Ensure wires are not too close to the mirrored glass.
7. Reassemble the firebox.

Figure 7 Models XLF5017-XD, XLF6017-XD, and XLF7417-XD Electronics

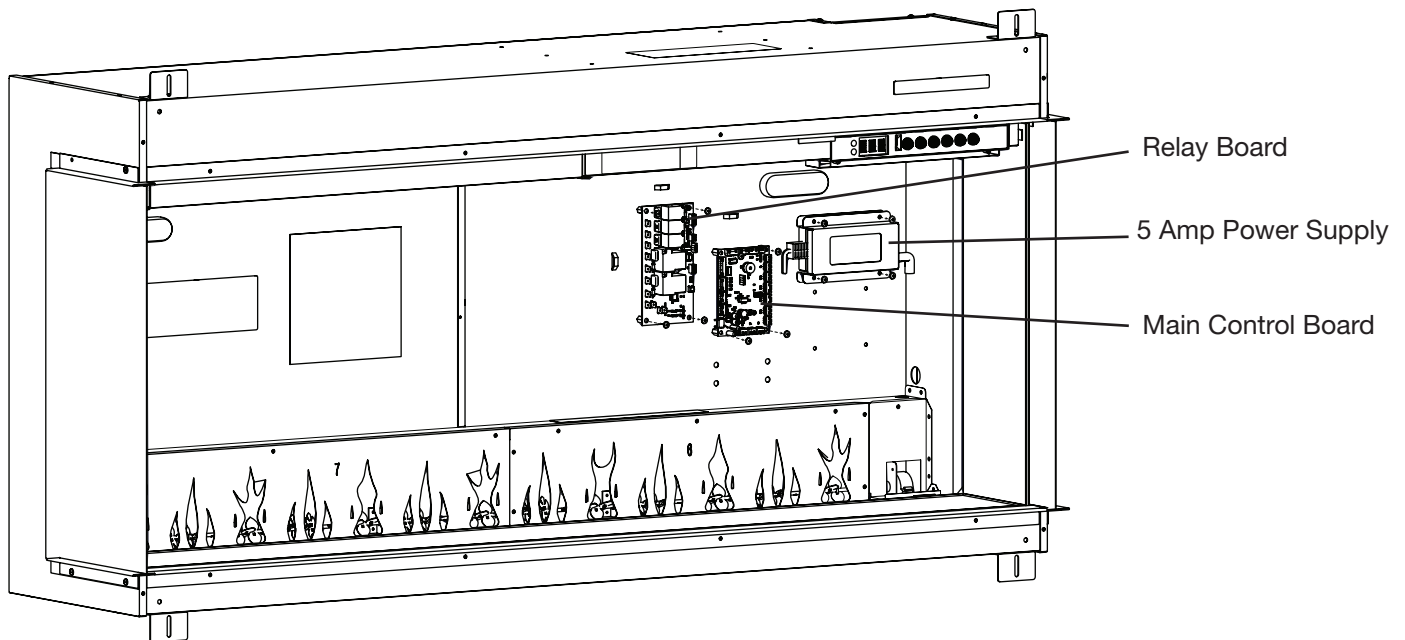

Relay Board Replacement

Tools Required: Phillips-Head Screwdriver
Pliers

1. Follow the instructions for *Preparing Firebox for Service* on page 10.
2. Remove the screw on each corner of the relay board (4 total) (**Figure 7 / Figure 8**).
3. Disconnect the wires from the relay board, noting their original locations.
4. Secure the new relay board using the previously removed screws.
5. Connect the wires on the new relay board in the correct locations.
6. Ensure wires are not too close to the mirrored glass.
7. Reassemble the firebox.

Adapter Board Replacement (XLF8817-XD & XLF10017-XD)

Tools Required: Phillips-Head Screwdriver

1. Follow the instructions for *Preparing Firebox for Service* on page 10.
2. Remove the screw on each corner of the adapter board (4 total) (**Figure 8**).
3. Disconnect the wires from the adapter board, noting their original locations.
4. Secure the new adapter board using the previously removed screws.
5. Connect the wires on the new adapter board in the correct locations.
6. Ensure wires are not too close to the mirrored glass.
7. Reassemble the firebox.

Figure 8 Models XLF8817-XD and XLF10017-XD Electronics

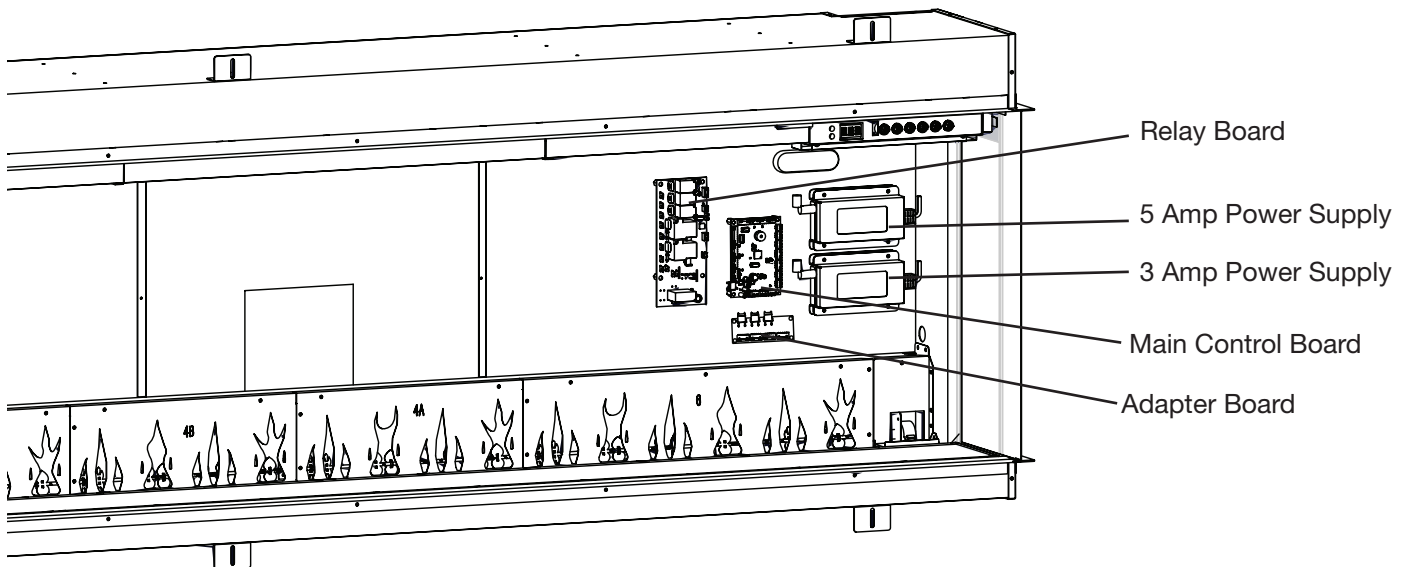

Hidden Touch Controls Replacement

Tools Required: Phillips-Head Screwdriver

1. Follow the instructions for *Preparing Firebox for Service* on page 10.
2. Remove the screws on either side of the hidden touch controls bracket (**Figure 9**).
3. Remove the 4 screws that secure the board to the bracket (**Figure 10**).
4. Properly orient the new board on the bracket (the connector pins should align with the cutout).
5. Secure the board using the 4 screws previously removed. Do not overtighten.
6. Connect the connector to the board.
7. Secure the bracket on the upper housing.
8. Replace the QR Code labels provided over the existing QR label on the fireplace and the owner's manual (**Figure 11**)
If using the Flame Connect app, you will need to reconnect your fireplace to the app following replacement of the hidden touch controls..
9. Reassemble the firebox.

Figure 9

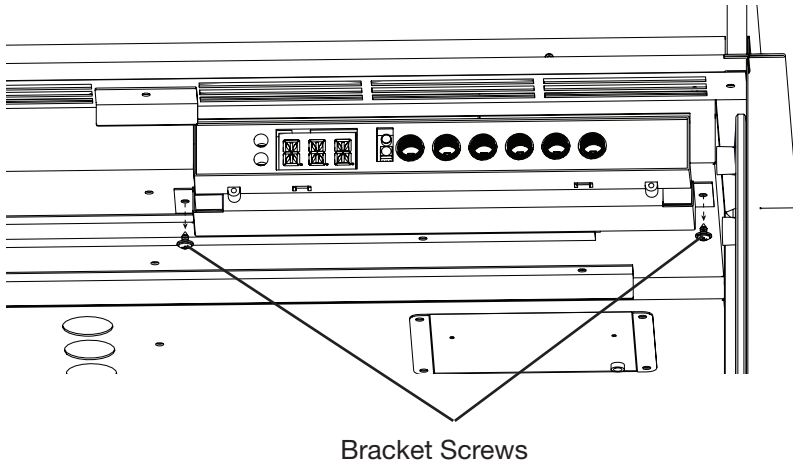

Figure 10

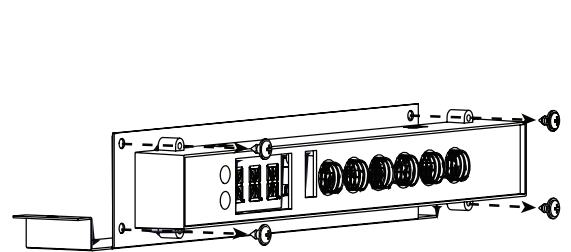
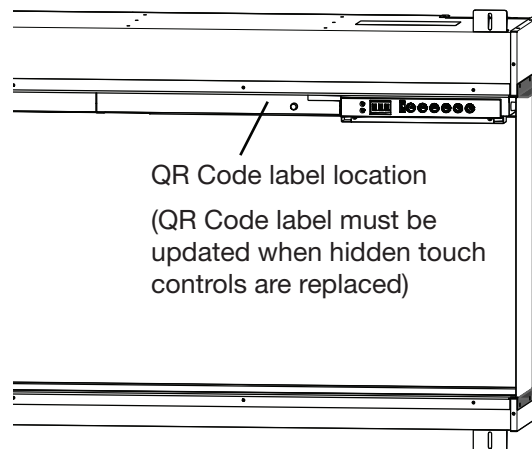

Figure 11



Temperature Sensor (NTC) Replacement

Tools Required: Phillips-Head Screwdriver
Side Cutters

1. Follow the instructions for *Preparing Firebox for Service* on page 10.
2. Remove the 4 screws on the NTC bracket (**Figure 12**).
3. Trace the NTC wire to the mainboard.
4. Disconnect the NTC and remove it, cutting any restrictive wire ties. Make note of the location of the NTC connector.
5. Feed the connector from the new NTC toward the main control board, and connect it into the correct location.
6. Secure the new NTC on the NTC bracket using the provided wire tie.
7. Secure the bracket using the 4 screws previously removed.
8. Reassemble the firebox.

Figure 12

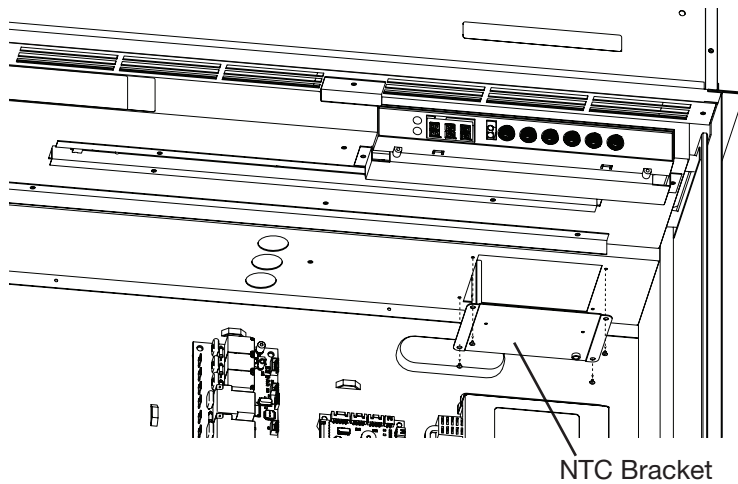

Flicker Motor Replacement

Tools Required: Phillips-Head Screwdriver

1. Follow the instructions for *Preparing Firebox for Service* on page 10.
2. Remove the 10 screws that secure the flame panel furthest to the right (**Figure 13**).
3. Remove the 9 screws that secure the flicker motor housing (**Figure 14**).
4. Remove the 2 screws that secure the flicker motor bracket to the back panel (**Figure 15**).
5. Detach the flicker rod from the flicker motor by carefully flexing it and pulling out the rubber sleeve (**Figure 15**).
6. Remove the 2 screws that secure the flicker motor to the flicker motor bracket (**Figure 16**).
7. Trace the wires from the defective flicker motor to the main control board.
8. Disconnect the flicker motor from the main control board and remove it, cutting any restrictive wire ties.
9. Connect the new flicker motor in the correct location on the main control board.
10. Secure the flicker motor to the flicker motor bracket using the 2 screws previously removed.
11. Secure the flicker motor bracket to the back of the firebox, using the 2 screws previously removed.
12. Re-bundle the wires using the provided wire tie.
13. Attach the flicker rod to the flicker motor.
14. Secure the flicker motor housing, using the 9 screws previously removed.
15. Reassemble the firebox.

Figure 13

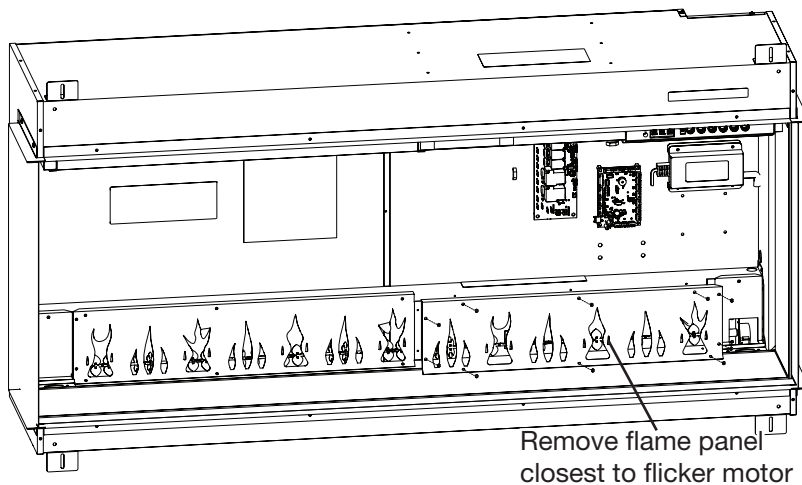

Figure 14

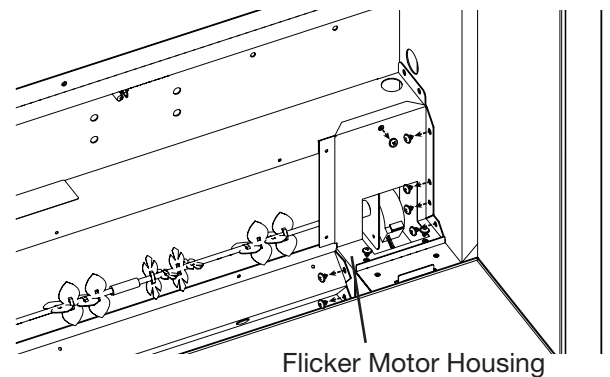

Figure 15

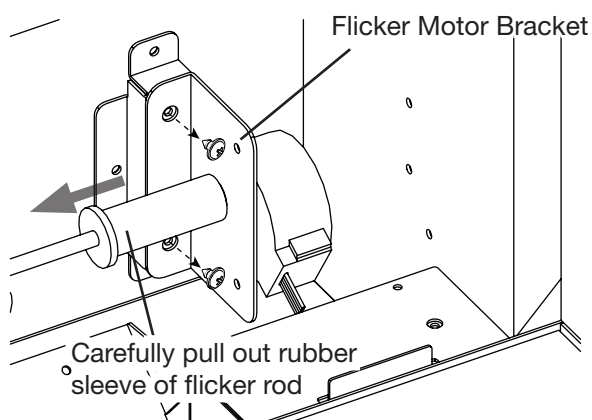
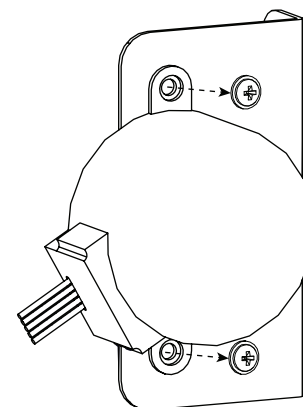

Figure 16



Flame LED Replacement

Tools Required: Phillips-Head Screwdriver
Pliers

1. Follow the instructions for *Preparing Firebox for Service* on page 10.
2. Remove the screws that secure the flame panels (number of screws will vary) (Figure 17). Set the flame panels aside, making note of their original order as they are removed.
3. Remove the 2 screws on each extremity (4 total) of the flame LED bracket (Figure 18).
4. Pinch each rivet using pliers while gently pulling the LED board off to release it (Figure 19).
5. Position the new flame LED board, and secure it by gently pressing it onto the rivets. Ensure the IN marking on the board is oriented toward the right side.
6. Secure the flame LED bracket using the 4 screws previously removed.
7. Reinstall the flame panels in the order opposite of which they were removed, ensuring they remain in the correct order.
8. Reassemble the firebox.

Figure 17

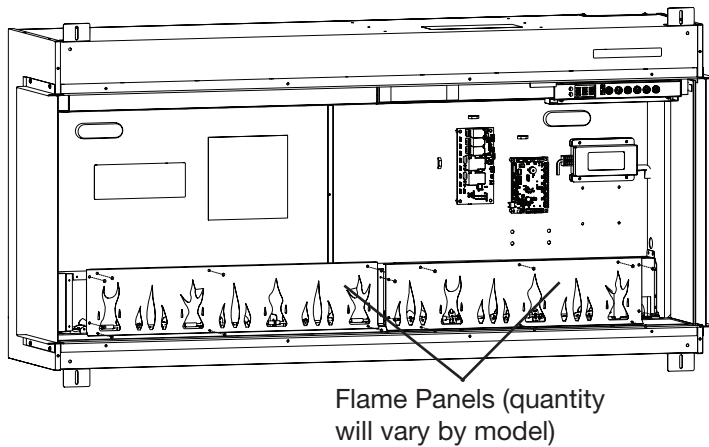

Figure 18

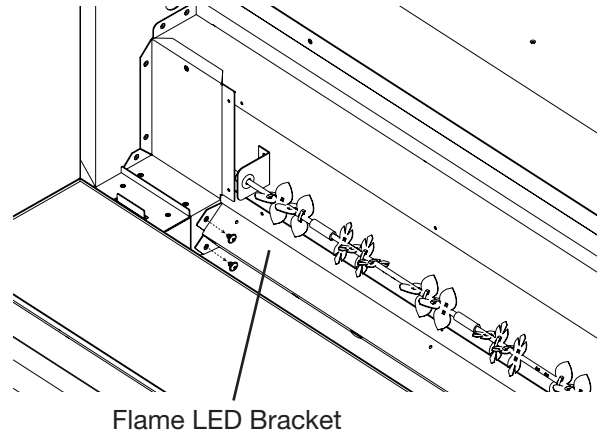
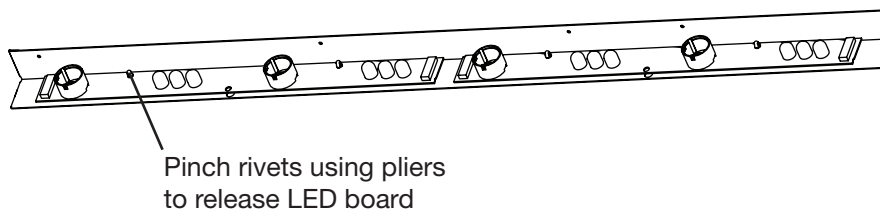

Figure 19



Media Bed LED Replacement

⚠ WARNING: If the firebox was operating prior to servicing, allow at least 10 minutes for the heating elements to cool off to avoid accidental burning of skin.

⚠ WARNING: Disconnect power before attempting any maintenance to reduce the risk of electric shock or injury to persons.

Tools Required: Phillips-Head Screwdriver
Suction Cup (if available)

1. Remove front glass bracket(s) (Figure 1, page 10).
2. Tilt the front glass outward and lift to remove it. Set it in a safe place for the duration of the service (Figure 2, page 10).
3. Remove the media and put it aside for the duration of the service.
4. Remove the media tray using the suction cup, if available (Figure 20).
5. Remove the defective media LED board from the bracket by pinching each rivet using pliers, while gently pulling the board off to release it (Figure 20).
6. Disconnect the connector from the defective media LED board.
7. Position the new media LED board, and secure it by gently pressing it onto the rivets. Ensure the IN marking on the board is oriented toward the right side.
8. Reassemble the firebox.

Figure 20

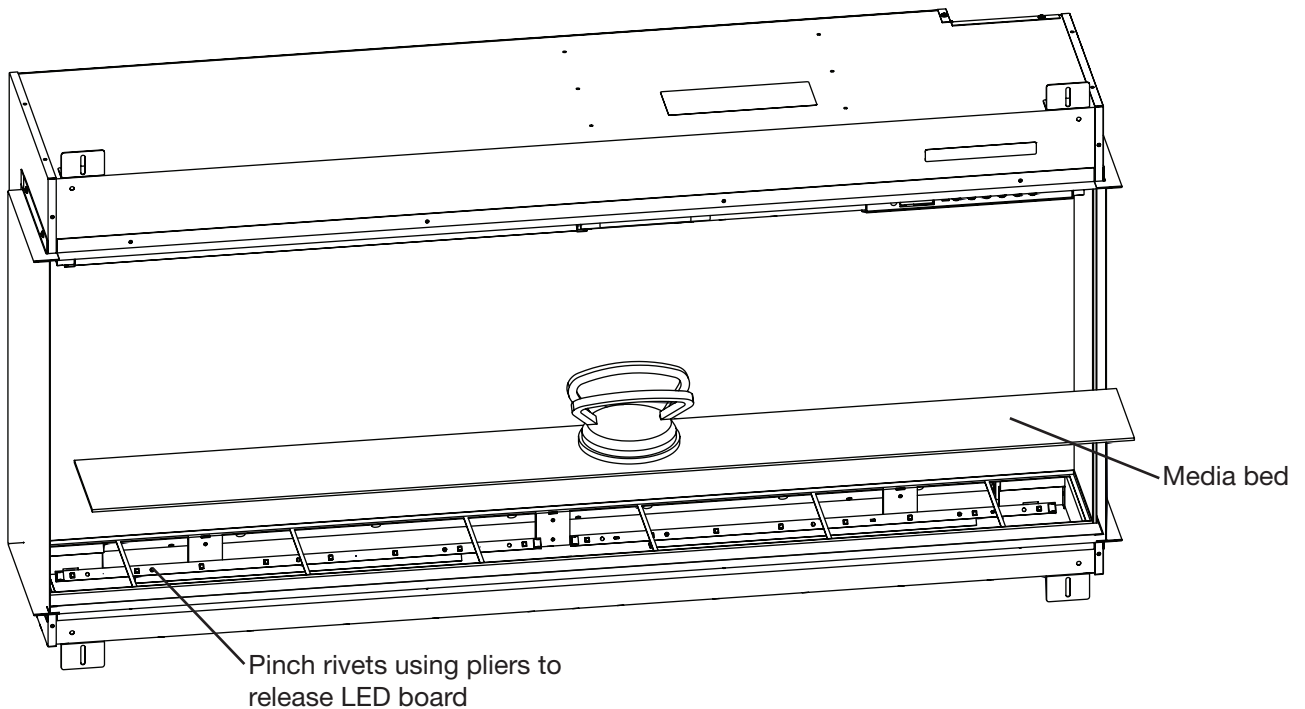

Overhead LED Replacement

⚠ WARNING: If the firebox was operating prior to servicing, allow at least 10 minutes for the heating elements to cool off to avoid accidental burning of skin.

⚠ WARNING: Disconnect power before attempting any maintenance to reduce the risk of electric shock or injury to persons.

Tools Required: Phillips-Head Screwdriver
Pliers

1. Remove front glass bracket(s) (Figure 1, page 10).
2. Tilt the front glass outward and lift to remove it. Set it in a safe place for the duration of the service (Figure 2, page 10).
3. Remove the 4 screws that secure the overhead LED bracket where the defective overhead LED board is located (Figure 21).
4. Disconnect the defective overhead LED board
5. Remove the defective overhead LED board from the bracket by pinching each rivet using pliers, while gently pulling the board off to release it (Figure 22).
6. Position the new overhead LED board, and secure it by gently pressing it onto the rivets. Ensure the IN marking on the board is oriented toward the right side.
7. Secure the overhead LED bracket using the 4 screws previously removed.
8. Reassemble the firebox.

Figure 21

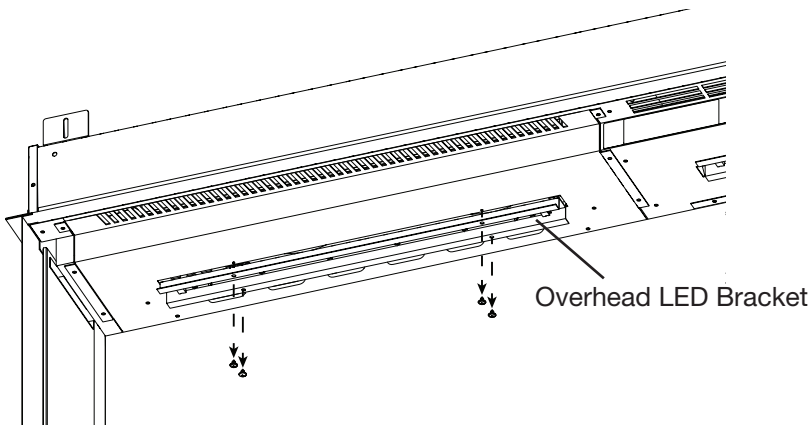
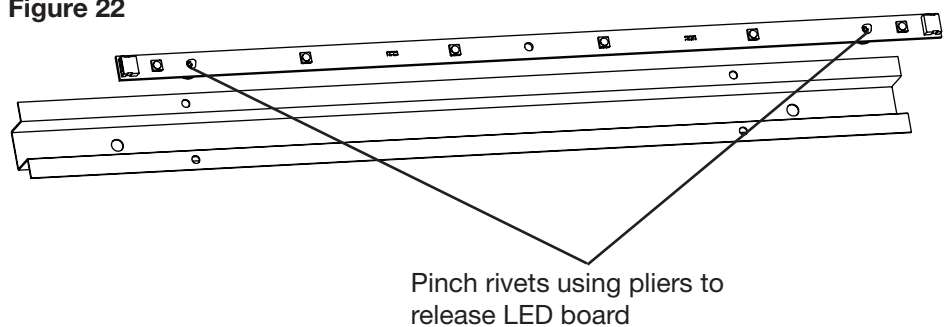





Figure 22



Troubleshooting

Problem	Display	Cause	Solution
Circuit breaker trips or fuse blows when unit is turned on	N/A	Improper circuit current rating	Install unit on a dedicated minimum 15 amp circuit.
Fireplace does not turn on with the manual touch controls	N/A	No incoming power	Ensure unit is wired correctly Check main disconnect panel Ensure wall switch is on (if applicable)
		Front glass was installed after unit was powered on	Turn power off (from breaker or outlet), install front glass before turning power back on.
		Defective hidden touch controls	Replace hidden touch controls
		Defective main control board	Replace main control board
		Defective relay board	Replace relay board
Fireplace does not turn on with the remote control	N/A	The batteries in the remote control are dead or installed incorrectly	Replace remote control battery Ensure battery is installed with + facing up.
		Defective remote control	Replace remote control
		Defective IR receiver	Replace hidden touch controls
Heater does not turn on	---	Heater is disabled	Press and hold  and  at the same time on the hidden touch controls for 3 seconds to disable or enable the heat function.
	H—	Heater has been permanently disabled	If installation with heat is desired, jumper on main board if available or purchase new main board.
Heater is on, but there is no heat		Normal operation — There is a 30-second delay before heater starts	No action required.
		Thermostat setting is below ambient temperature	Turn up the thermostat setting to be above ambient temperature
Error Code is displayed	Err 1	Temperature cut-out is activated	Reset breaker and wait 30 minutes before turning unit back on it. Ensure heater intakes and exhausts are not obstructed. Clean with compressed air if necessary. Defective heater assembly.
	Err 2	L1 voltage is too high	If error persists, consult an electrician.
	Err 3	L1 voltage is too low	If error persists, consult an electrician.
	Err 4	L1 current is too high	If error persists, consult an electrician.
	Err 5	Fan not detected	Fan wire is disconnected. Defective heater assembly. Defective relay board.
	Err 6	Fan error	Defective heater assembly.
	Err 7	Fan is slow	Clean fan. Defective heater assembly.
	Err 8	Element error	Defective heater assembly.
	Err 9	Element not detected	Element wire(s) is/are disconnected. Defective heater assembly.

Error Code is displayed	<i>Err 12</i>	Ambient temperature is above 45° C (113° F)	No action required.
	<i>Err 13</i>	Ambient temperature is below 45° C (113° F)	No action required.
	<i>Err 14</i>	NTC error	NTC is unplugged. NTC is defective. Main Control Board is defective.
	<i>Err 15</i>	NTC has shorted	NTC is unplugged. NTC is defective.
	<i>Err 16</i>	NTC not detected	NTC is unplugged. NTC is defective.
	<i>Err 17</i>	Media bed LEDs defective	Defective Media Bed LEDs. Defective Main Control Board
	<i>Err 18</i>	Overhead LEDs defective	Defective Overhead LEDs. Defective Main Control Board
	<i>Err 19</i>	Media bed LEDs not detected	Media Bed LEDs disconnected. Defective Media Bed LEDs. Defective Main Control Board
	<i>Err 20</i>	Overhead LEDs not detected	Overhead LEDs disconnected. Defective Overhead LEDs. Defective Main Control Board
	<i>Err 21</i>	Flame LEDs not detected	Flame LEDs disconnected. Defective Flame LEDs. Defective Main Control Board
	<i>Err 22</i>	Flicker motor not detected	Flicker motor is disconnected. Defective Flicker motor. Defective Main control board.
	<i>Err 23</i>	Relay board not detected	Relay board is disconnected. Defective Relay board.
	<i>Err 24</i>	Main control board not detected	Main control board is disconnected. Defective Main control board.
<i>Err 25</i>	Display board not detected	Defective Display board. Defective Main control board.	

App

For troubleshooting information related to the Flame Connect app, please visit www.dimplex.com/fcapp

1-888-346-7539 | www.dimplex.com

In keeping with our policy of continuous product improvement, we reserve the right to make changes without notice.

© 2022 Glen Dimplex Americas

 A BRAND OF GLEN DIMPLEX AMERICAS

REV	ECO	DATE
00	ECO-000201	13-APR-21
01	ECO-000208	28-MAY-21
03	ECO-000436	24-MAY-22