



INSTALLATION, OPERATION AND MAINTENANCE MANUAL

Warning

Please read carefully before proceeding with installation. Your failure to follow any attached instructions or operating parameters may lead to the products failure and possible damage to property.

Save manual for future reference

MODEL

WP-5 WP5-50 KP-5 RO-5M



System Tested and certified by NSF International against ANSI/NSF Standard 58 for the reduction of the claims specified on the performance data sheet.

Refer to enclosed warranty for operating parameters to ensure proper use with your water supply.

Watts Premier, Inc.
Phone: 800-752-5582

8716 W Ludlow Drive Suite #1
www.wattspremier.com

Peoria, AZ 85381
Fax: 623-866-5666

Thank you for your purchase of a state of the art Watts Premier Reverse Osmosis (RO) water treatment system. Water quality concerns are quickly becoming more of a focus for the public. Lately you may have heard about contaminants in the drinking water, such as arsenic, chromium, cryptosporidium or Giardia. There may also be some local water issues in your area such as high levels of lead and copper. This Watts Premier water treatment system has been designed and tested to provide you with high quality water for years to come. The following is a brief overview of the system.

Your Reverse Osmosis System:

Osmosis is the process of water passing through a semi permeable membrane in order to balance the concentration of contaminants on each side of the membrane. A semi permeable membrane is a barrier that will pass some particles like clean water, but not other particles like arsenic and lead.

Reverse osmosis uses a semi permeable membrane; however, by applying pressure across the membrane, it concentrates contaminants (like a strainer) on one side of the membrane, producing crystal clear water on the other. This is why RO systems produce both clean drinking water and waste water that is flushed from the system. This reverse osmosis system also utilizes carbon block filtration technology, and can therefore provide a higher quality drinking water than carbon filtration systems alone.

Your system is a five stage RO which is based upon five separate treatment segments within the one complete water filtration system. These stages are as follows:

Stage 1 – Sediment filter, recommended change 6 months.*

The first stage of your RO system is a five micron sediment filter that traps sediment and other particulate matter like dirt, silt and rust which affect the taste and appearance of your water.

Stage 2 and 3 – Carbon filters, recommended change 6 months.*

The second and third stages each contain a 5 micron carbon block filter. This helps ensure that chlorine and other materials that cause bad taste and odor are greatly reduced.

Stage 4- Membrane, recommended change 2-5 years.

Stage four is the heart of the reverse osmosis system, the RO membrane. This semi permeable membrane will effectively take out TDS, Sodium and heavy metals such as arsenic, copper, and lead, as well as Cysts, such as Giardia and cryptosporidium. Because the process of making this high quality drinking water takes time, your RO water treatment system is equipped with a storage tank.

Stage 5- Carbon in-line filter, recommend change 6 - 12 months.

The final stage is an in-line granular activated carbon (GAC) filter. This filter is used after the water storage tank, and is used as a final polishing filter.

System Maintenance

Just because you can not taste it, does not mean that it is not there. Contaminants such as lead, chromium and arsenic (to name a few) are undetectable to the taste. Additionally, over time if you do not replace the filter element, other bad tastes and odors will be apparent in your drinking water.

This is why it is important to change out your filter at the recommended intervals as indicated in this system manual. When replacing the filter elements, pay special attention to any cleaning instructions. Should you have any further questions please refer to our web site at www.wattspremier.com or call our customer service dept. at **1-800-752-5582**.

*KP-5 R.O. unit is equipped with annual filters, therefore require only one annual filter change.

With proper installation and maintenance, this system will provide you with high quality water for years to come. All of Premier's water enhancement products are rigorously tested by independent laboratories for safety and reliability. If you have any questions or concerns, please contact our customer service department at 1-800-752-5582 (outside USA 480-675-7995) or refer to our on-line troubleshooting guide at www.wattspremier.com.

Before installation, please take a moment to fill out the warranty card on page 25.

Table of Contents

Operational Parameters.....	4
Contents of Reverse Osmosis System.....	4
Installation & Startup	
Tools Recommended For Installation	4
Plumbing diagram and parts list.....	5
Drill a Hole for the Reverse Osmosis Faucet	6
How to use Quick Connect Fittings on Your RO System	6
Standard Faucet Installation	7
Adapt-a-Valve Installation	8
Reverse Osmosis Module Mounting.....	8
Drain Saddle Installation.....	9
Drain Saddle Tube Connection.....	9
Green Tube Connection	10
Tank Elbow Installation.....	10
Connect Blue Tube from “TANK” Port on RO Module to the Tank.....	10
Connect the Red Tube from Faucet to RO Module	10
Final Polishing Filter Installation.....	11
Start up Instructions.....	12
Maintenance & Troubleshooting	
Six Month Maintenance	13
Annual Maintenance	14
Membrane Replacement	15
Check Air Pressure in the Tank	16
Procedure for Extended Non-Use (More than 2 months).....	16
Troubleshooting	17
Product Technical & Warranty Information	
Performance Data Sheet.....	18-19
California Certification	20
Arsenic Fact Sheet	21
Other Products from Watts Premier	22-24
Warranty Registration.....	25-26
Service Record.....	27
Limited Warranty	28

Operational Parameters

Installation must comply with State and local plumbing regulations. Do not use with water that is micro biologically unsafe or of unknown quality without adequate disinfection before or after the system. System is intended to be installed using the cold water supply only.

Operating Temperatures:	Maximum 100°F (37.8°C)	Minimum 40°F (4.4°C)
Operating Pressure:	Maximum 100 psi (7.0 kg/cm ²)	Minimum 40 psi (2.80 kg/cm ²)
pH Parameters:	Maximum 11	Minimum 2
Iron:	Maximum 0.2 ppm	
TDS (Total Dissolved Solids)	< 1800 ppm	
Turbidity	< 5 NTU	
Hardness	Maximum 10 Grains Per Gallon *	

Hardness: Recommended hardness not to exceed 10 grains per gallon, or 170 parts per million.

* System will operate with hardness over 10 grains but the membrane life may be shortened.

Addition of a water softener may lengthen the membrane life.

Water Pressure: The operating water pressure in your home should be tested over a 24 hour period to attain the maximum pressure. If the incoming water pressure is above 100 psi then a water pressure regulator is required. A booster pump is needed for incoming water pressure under 40psi.

Copper Tube: Reverse Osmosis water should not be run through copper tube as the purity of the water will leach copper causing an objectional taste in water and pin holes may form in the tube.

Contents of the Reverse Osmosis (RO) System

- 1 Tank
- 1 Module – (Filters Pre-Installed)
- 1 Parts Bag – With a 6” or 10” Final Filter
- 1 Faucet Bag
- 1 Manual



If any of the items are missing please contact Premier prior to installing.

INSTALLATION & STARTUP

Tools Recommended For Installation

- √ 1 1/4" Diamond Tipped Hole Saw bit for faucet opening (Counter Tops/Porcelain & Stainless Sinks)
- √ 1 1/4" Adjustable Wrench
- √ 1/2" Open End Wrench
- √ 5/8" Open End Wrench
- √ Electric Drill
- √ 1/8" diamond tip bit, pilot hole
- √ 1/4" drain saddle hole
- √ Phillips bit for electric drill
- √ Needle Nose Pliers
- √ Adjustable Pliers
- √ Sharp Knife
- √ Phillips Screw Driver



Parts List

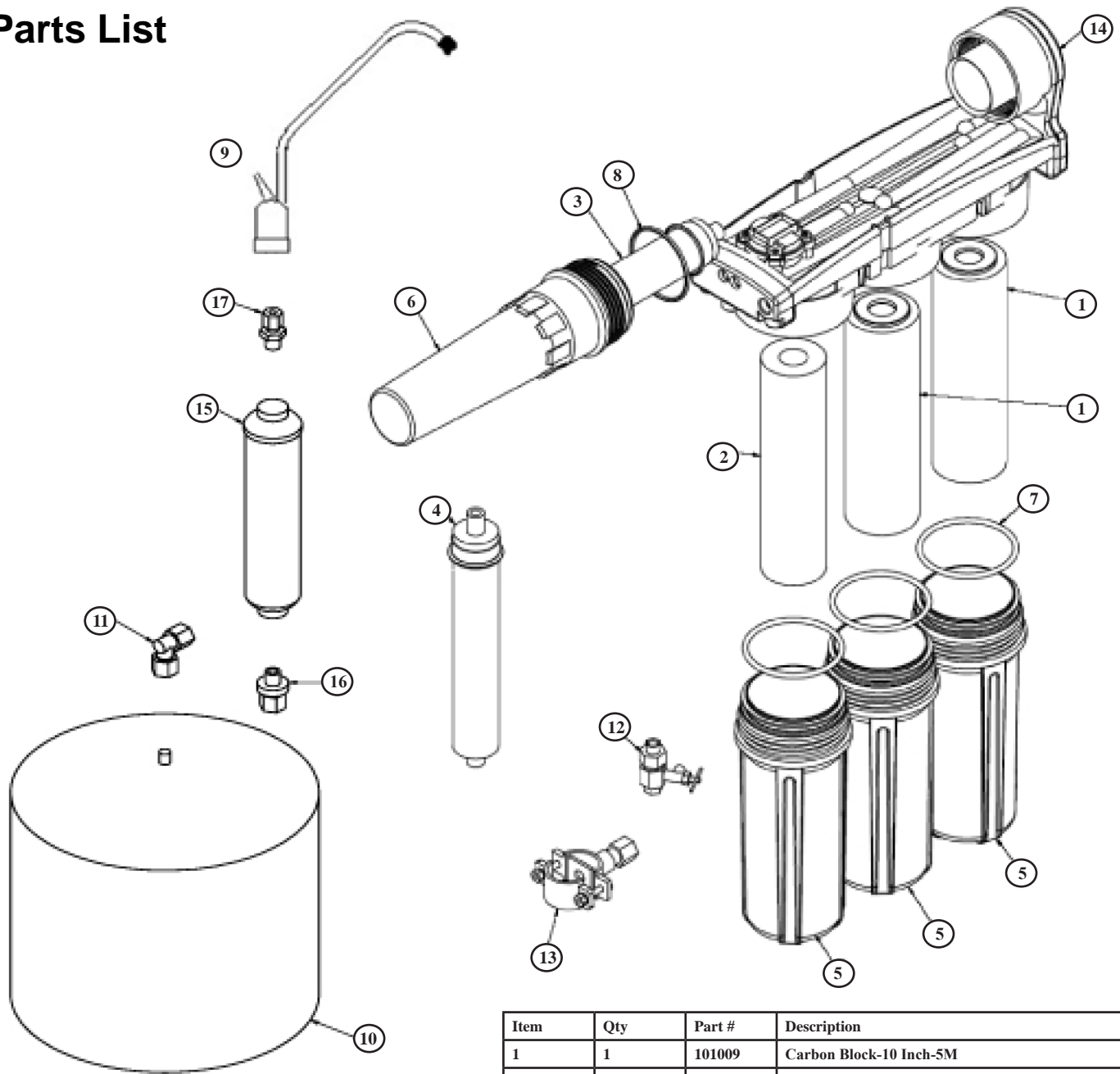

Item	Qty	Part #	Description
1	1	101009	Carbon Block-10 Inch-5M
2	1	104017	Sediment Filter-10 Inch-5M
3	1	110016	RO Membrane 35GPD
4	1	110019	RO Membrane 50GPD - Upgrade
5	3	113018	Filter Bowl
6	1	113035	Membrane Vessel
7	3	113041	O-Ring Filter Bowl
8	1	113045	O-Ring Membrane Vessel
9	1	116001	Faucet-AG-Chrome
10	1	119007	Tank-Pressure 3GAL White
11	1	125032	Elbow Fitting 3/8" Tank
12	1	560080	Adapt-a-Valve
13	1	164016	Drain Saddle 3/8"
14	1	610013	Prepared Lid, Manifold
15	1	100017	10" Inline Filter
16	1	400031	Fitting 3/8"C x 1/4"MPT
17	1	125017	Fitting 1/4"C x 1/4"MPT

Drill a Hole for the Reverse Osmosis Faucet

Marble Counter-top

We recommend contacting a qualified contractor for drilling a hole in a marble counter-top.

Counter Top / Porcelain & Stainless Steel Sink

Note: Most sinks are pre drilled with 1 ¼” diameter hole that you can use for your RO faucet. (If you are already using it for a sprayer or soap dispenser, see step 1)

Porcelain sinks are extremely hard and can crack or chip easily. Use extreme caution when drilling. Watts accepts no responsibility for damage resulting from the installation of faucet. Diamond tip bit recommended.

- Step 1 Determine desired location for the RO faucet on your sink and place a piece of masking tape over where the hole is to be drilled. Mark the center of the hole on the tape.
- Step 2 Using a variable speed drill set on the slowest speed, drill a 1/8” pilot hole through both porcelain and metal casing of sink at the marked center of the desired location. Use lubricating oil or liquid soap to keep the drill bit cool (If drill bit gets hot it may cause the porcelain to crack or chip).
- Step 3 Using a 1 ¼” diamond tip hole saw, proceed to drill the large hole. Keep drill speed on the slowest speed and use lubricating oil or liquid soap to keep the hole saw cool during cutting.
- Step 4 After drilling, remove all sharp edges and make sure the surroundings of the sink are cooled before mounting the faucet.



How to use the Quick Connect Fittings

To make a connection, the tube is simply pushed into the fitting. The unique locking system holds the tube firmly in place without deforming it or restricting flow. Use the steps below in reference to any quick connect tube connections.

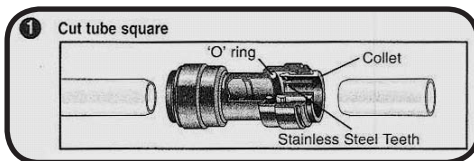

It is essential that the outside diameter be free of score marks and that burrs and sharp edges be removed before inserting into fitting.

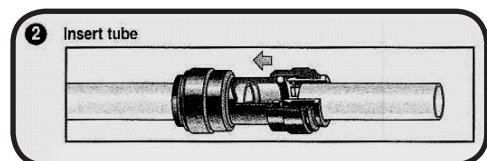

Fitting grips before it seals. Ensure tube is pushed into the tube stop.

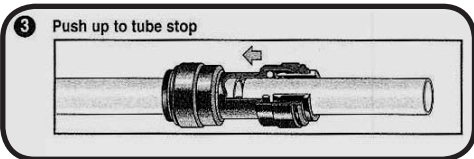

Push the tube into the fitting, to the tube stop. The collet (gripper) has stainless steel teeth which hold the tube firmly in position while the O-ring provides a permanent leak proof seal.

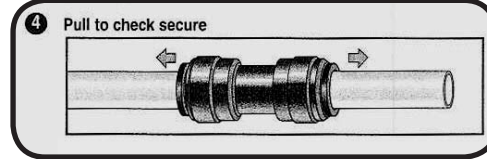

Pull on the tube to check that it is secure. It is a good practice to test the system prior to leaving site and /or before use.

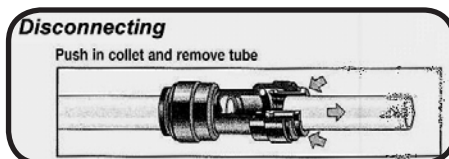

To disconnect, ensure the system is depressurized before removing the tube. Push in the collet squarely against face of fitting. With the collet held in this position, the tube can be removed. The fitting can then be reused.

WATTSPremier Standard Faucet Installation

Parts List

1. Faucet
2. Black Drain Tube (3/8" Black)
3. Red Tube 1/4"
4. Escutcheon Plate
5. Full Circle Rubber Gasket
6. Slotted Metal Washer
7. Plastic Sleeve
8. Plain Washer
9. Hex Nut Washer
10. Hex Nut
11. Plastic Tube Insert
12. White Plastic Delrin Sleeve
13. Water Connector Nut
14. Blue Tube 1/4"

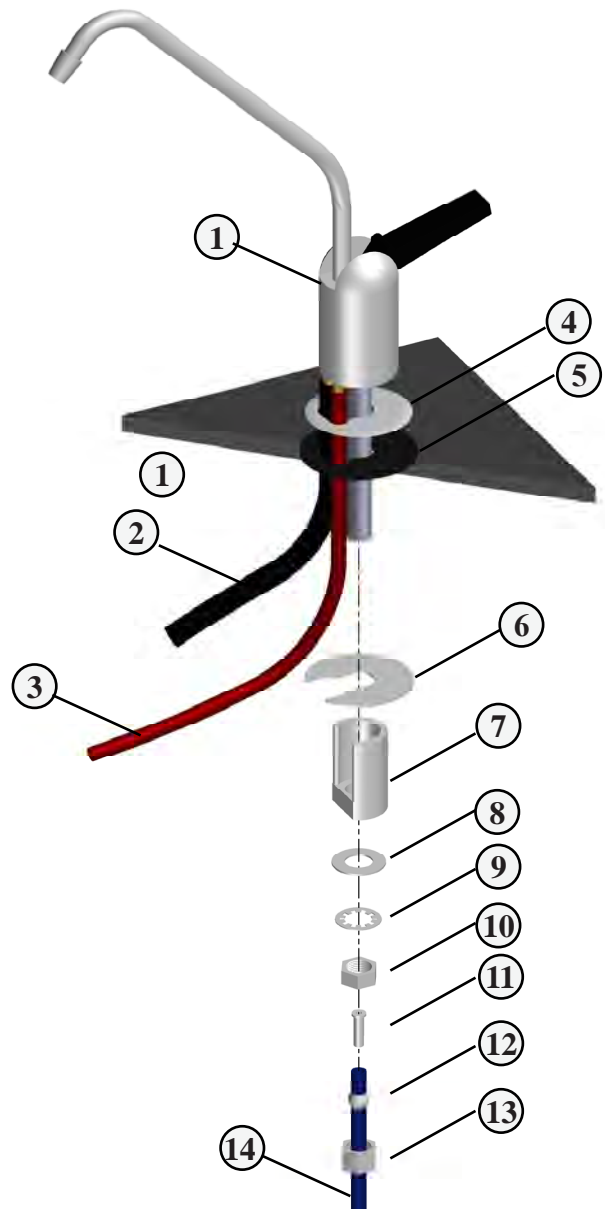

Step 5 Feed both the red and black tubing through the pre drilled hole in the sink/counter until faucet is seated.

Step 6 Under the sink - on to the threaded faucet stem in order first slide on the slotted washer (item 6), the white spacer with the open end UP (item 7), the plain washer (item 8), the hex nut washer (item 9), and lastly secure with nut (item 10).

Adapt-a-Valve Installation

Caution: Water supply line to the system must be from the cold water supply line only. Hot water will severely damage your system.

Verify contents prior to installation:

- (1) - Plastic Adapt-a-Valve with black collet
- (1) - Brass Adapter no washer
- (1) - Brass Adapter with black washer
- (1) - White rubber washer

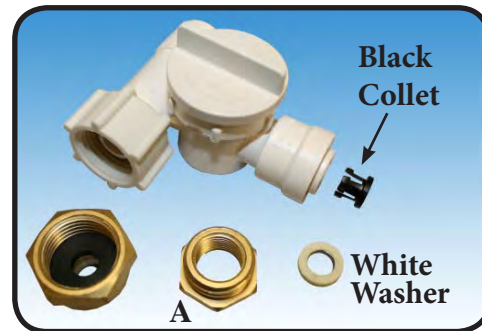

3/8" Configuration
(With Brass Fittings)
* Insert White Washer



Hot Supply Cold Supply



1/2" Configuration
(Without Brass Fittings)

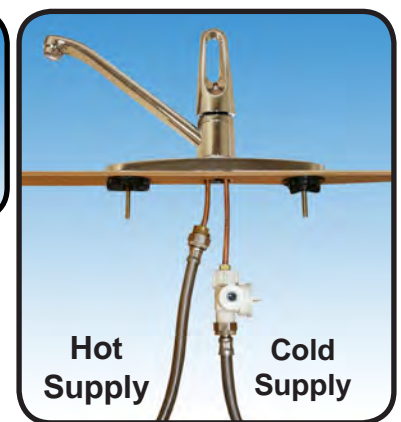

WARNING: Do not use Teflon tape with the Adapt-a-Valve.

Step 7 Turn off the cold water supply to the faucet by turning the angle stop valve completely off. Open cold water sink faucet to relieve pressure.

Step 8 Choosing the configuration that fits your plumbing, attach the adapt-a-valve as illustrated in the four photos above.

TIPS: Make sure that the black collet is installed in to the 1/4" opening on the Adapt-a-valve.
Don't forget to install the white compression washer with the 3/8" configuration.
Brass adapter (A) does not need to be tightened with a wrench, only finger tight.

Reverse Osmosis Module Mounting

Step 9 Determine best location for the RO module to be mounted to allow for future system maintenance. Using the mounting holes on the bracket, mark the location for the mounting screws on the cabinet wall under the sink. In the parts bag, locate the two self tapping screws. Using an electric drill with a Phillips bit, screw them into the cabinet at the marked location. Hang the module on the screws using the mounting holes in the bracket



Note: Do not cut any RO system tubes at this time

Drain Saddle Installation

Drain Saddle fits standard 1 ¼" – 1 ½" drain pipes

Caution: *If you have a garbage disposal, do not install the drain saddle near it. Installation of the drain saddle must be either above the garbage disposal, or if a second sink drain is available, install it above the cross bar on the second drain. Installation of the drain saddle near a garbage disposal may cause the drain line to plug. If no other installation of drain line is available, Watts Premier offers drain line installation kit (part number 164020) that can be used with garbage disposals.*



Step 10 Gather the pieces of the drain saddle:

- | | |
|-------------------------|-----------------------------------|
| 1 Black compression nut | 1 Semicircle bracket with opening |
| 2 Screws | 1 Foam gasket |
| 2 Nuts for screws | 1 Semicircle bracket |

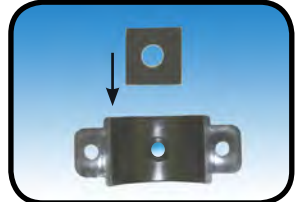

Step 11 The small square black foam gasket with a circle cut out of the middle must be applied to the inside of the drain saddle. Remove sticky tape backing and stick to the drain saddle as shown.



Step 12 The drain saddle must be mounted at least 1 ½" above the nut of the P-trap or cross bar from the garbage disposal to insure proper drainage. Assemble the drain saddle around the drain pipe at the best available location. Using Phillips screw driver tighten screws evenly and securely on both sides of the drain saddle. Keep the plastic compression nut off at this time.



Caution: *Do not over tighten the screws. It may crack the drain saddle.*

Drill hole and Connect 3/8" Black Tube from Faucet to the Drain Saddle

IMPORTANT:

The black 3/8" drain tube must be as SHORT and STRAIGHT as possible to the drain saddle, making a downward slope from faucet to drain saddle to allow for proper drainage. This is a gravity fed line and if there is any bend or dip in the tube, the rinse water will not flow into the drain properly. Water may back up and come out the air gap hole in the back of the faucet.

Step 13 With the drain saddle secured onto the drain pipe, using a 1/4" drill bit installed in your electric drill, insert the drill bit through the opening in the drain saddle and drill into the drain pipe.



Caution: It is very important to keep the drill centered to prevent damage of the drain saddle while drilling.

Step 14 Measure the 3/8" black tube from faucet to the drain saddle on the drain pipe and make a straight cut to the correct length.

Step 15 Slip black tube through black compression nut. Insert black tube into the opening in the drain saddle and hand tighten the black nut, and add 1/4 turn with a wrench.



Green Tube Connection

- Step 16 Locate green tube attached to the RO Module. Insert the open end of the green 1/4" tube into the open 1/4" quick connect fitting on the plastic water feed valve making sure the tube is pushed in all the way to the tube stop.

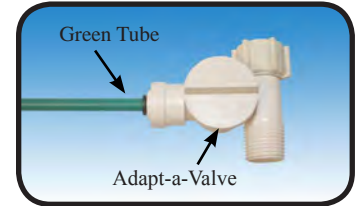

Tank Elbow Installation

- Step 17 Wrap (7 to 12 turns) of Teflon tape clockwise around the male pipe threads (MPT) on the Stainless Steel fitting on top of the tank.

Note: *Do not let the tape cover the opening.*

- Step 18 Thread the plastic elbow (supplied in the parts bag) onto the stainless steel connection on the top of tank. Tighten using an adjustable wrench. **Do not over tighten as plastic could crack.**



Connect Blue Tube from "TANK" Port on RO Module to the Tank

- Step 19 Position tank in desired location. Stand it upright or lay it on its side (using the black plastic stand). Measure the blue tube from the RO module port marked "TANK" over to the tank and cut it to desired length.
- Step 20 Insert the blue 3/8" tube into the compression side of the elbow previously installed on top of the storage tank and push in as far as it will go. Tighten the compression nut securely with a wrench.

Connect the Red Tube from Faucet to RO Module

- Step 21 Insert the open end of the red 1/4" tube attached to the RO faucet into the 1/4" X 1/4" quick connect fitting on the RO Manifold. Make sure the tube is pushed in all the way to the tube stop. (See Picture)

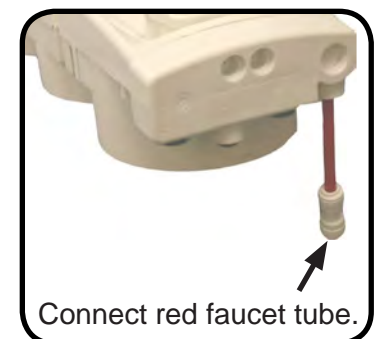

Final Polishing Filter Installation

Step 22 Remove the seal caps from both ends of the final filter.

Step 23 Thread the smaller (1/4") white plastic connector into the outlet end of the Final Filter and tighten (flow arrow on filter points to the 1/4" connector - see picture).



Step 24 Thread the larger (3/8") white plastic connector into the inlet end of the final filter (flow arrow on filter points away from the 3/8" connector - see picture).



Note: *Do not overtighten these connectors as it may damage them or the final filter.*

Step 25 Insert the 1/4" blue tube attached to the faucet into the outlet of the filter and tighten plastic nut securely. The flow arrow should be pointing toward the faucet. Insert the 3/8" blue tube attached to the module into the 3/8" inlet white connector on the in-line Final Filter. Tighten the white compression nuts with an adjustable wrench.

Note: *A connection to a refrigerator / ice maker may be tee'd into this blue tube and should be spliced in between the final filter and the RO faucet.*

Watts Premier offers an ice maker install kit part # 500010 (See Page 22).

Congratulations!

You have completed the installation of new your Reverse Osmosis system.

Please Follow the Startup Instructions.

Start up Instructions

- Step 1 Turn on the incoming cold water at the angle stop valve and the Adapt-a-Valve. Check the system for leaks and tighten any fittings as necessary. (Check frequently over the next 24 hours to ensure no leaks are present).



Note: *If you have connected your RO system to a refrigerator / ice maker, make sure the ice maker is off (do not allow water to flow to the ice maker) until flushing (Step 4) is complete and the tank has been allowed to fill completely. Connection from the RO to the ice maker system should have an in-line valve installed before the ice maker so it can easily be closed to prevent water flowing to the ice maker during start up and periodic maintenance. Your storage tank must be allowed to fill up fully in order for the ice maker system to work properly.*

- Step 2 Open the RO faucet and leave it open until water begins to trickle out (this may take a few minutes and the water will come out slowly).

- Step 3 Close the RO faucet allowing the storage tank to fill with water. It may take 3 to 6 hours to fill the tank completely depending on the production capability of the membrane, local water temperature and water pressure.

Note: *During the fill period you may hear water trickling which is a normal occurrence.*

- Step 4 After the storage tank has filled (the water trickling has stopped), open the RO Faucet to flush the tank completely. You will know that the tank is empty when the flow rate from the RO faucet is down to a trickle. Repeat this step two more times. The fourth tank can be used for drinking.

The flushing process should take about a day to complete.

Note: *Flushing of the tank 3 times is only necessary during the initial startup and after replacing the membrane.*

Don't Forget To Register!

Register by phone, fax, mail or internet. Watts Premier uses this information only to provide you with a filter change reminder service. Pre-filters should be changed every 6 months and the final in-line filter annually. You may register your system via our web site at www.wattspremier.com or call 1-800-752-5582 (within USA only) / FAX#: 450-675-7995. For Warranty card Please see page 25-26.

MAINTENANCE & TROUBLESHOOTING

6 Month System Maintenance

*Order filters by calling 1-800-752-5582 or buy online at www.wattspremier.com.

Items needed:

√ Stage 1 - Sediment Filter (part #: 104017)

√ Stage 2 & 3 - Carbon Block Filter (part #: 101009-White End Caps)

Note: *The filter wrench pictured (Part # 164003) may be purchased from Watts Premier to aid with twisting off filter housings (not required).*



Step 1 Turn off the incoming water supply to the RO at the feed water valve. (Follow the green tube away from the RO system to find the valve.)

Step 2 Open the RO Faucet and allow water to drain from the tank until it is completely empty.

Note: *Water may be saved in a container for drinking or to rinse system parts.*

Step 3 Let system sit for one minute after the tank is empty to let the system depressurize before attempting to remove filter housings.

Step 4 For more leverage you may leave the RO module attached to wall of cabinet. If you are unable to access the module while it is mounted, remove it prior to changing filters. Starting with the closest housing (Stage 1), remove it by turning it clockwise (left), empty water, then discard filter. Continue on to the 2nd housing (Stage 2) and 3rd housing (Stage 3).

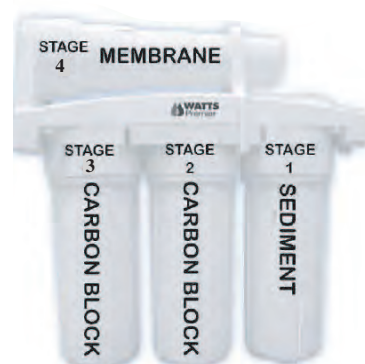

Step 5 Clean the filter housings (bowls) with a mild soap solution and rinse with water. Check O-rings and lubricate with water soluble lubricant. KY Jelly® or other water based lubricants may be used. Petroleum based lubricants (such as Vaseline®) must not be used.

Caution: *Before re-installing the filter bowls back on to the system, check O-rings to make sure they are still in place.*

Step 6 Insert the new sediment filter (cloth like appearance) into the 1st filter housing which is the one closest to the side with tubing connections and re-install housing.



Step 7 Insert the new Carbon Block filter (White End Caps) into the second and third stage housing and re-install housings.



Step 8 Turn water on to the unit at the adapt-a-valve.

Step 9 Open the RO faucet and leave it open until water begins to trickle out (it will come out slowly).

Step 10 Close the RO faucet allowing the storage tank to fill with water. It may take 3 to 6 hours to fill the tank completely depending on the production capability of the membrane, local water temperature and water pressure.



Annual Maintenance

*Order filters by calling 1-800-752-5582 or buy online at www.wattspremier.com.

- √ Stage 1 - Sediment Filter (part #: 104017)
- √ Stage 2 & 3 - Carbon Block Filter (part #: 101009-White end caps)
- √ Stage 5 - 10" Final Polishing Filter (part # 100017)
- √ 1/2 Cup of hydrogen peroxide or common household bleach.

Note: *Sanitizing of unit is recommended.*

Step 1 Perform steps 1 through 5 in the Six Month System Maintenance (Page 13).

Note: *If not sanitizing the system skip to step 8.*

Step 2 Remove the RO membrane from its housing and rest in a clean sanitary place. (Refer to "Membrane Replacement" section on page 15 for directions on removing the membrane). Replace cap onto empty membrane housing and re-connect green tubing.

Step 3 Leaving the filters out, replace stage 2 and 3 empty filter housings (hand tight) onto unit. Measure & pour either 1/2 cup of hydrogen peroxide or common household bleach into the 1st filter housing (Stage 1) and hand tighten onto unit.

Step 4 With the RO faucet in the closed position turn on the incoming water supply to the system by turning the adapt-a-valve counter clockwise. Wait 1 minute for the unit to pressurize. Turn on the RO faucet and let the water run for 30 seconds. Turn off the RO faucet and let the unit rest for 2 minutes. Finally, open the RO faucet and let the water run for 5 more minutes.

Step 5 Turn off the incoming water supply to the system by turning the adapt-a-valve clockwise until it stops. Keep the RO faucet open until the storage tank is completely drained.

Step 6 Open the membrane housing and re-install the RO membrane while making sure not to kink the O-rings. (Refer to "Membrane Replacement" section on page 15 for directions on installing the membrane). Tighten the cap back on the housing and reconnect green tubing.

Step 7 Remove filter housings Stage 1, 2 and 3 and empty of water.

Caution: *Before re-installing the filter bowls back on to the system , check O-rings to make sure they are still in place and lubricate with water soluble lubricant.*

Step 8 Insert the new sediment filter (cloth like appearance) into the 1st filter housing which is the one on the water inlet side (green tubing from the adapt-a-valve) of the RO system and re-install housing.

Step 9 Insert the new Carbon Block filter (White End Caps) into the 2nd and 3rd housing and re-install housing.

Step 10 The final in-line filter (Stage 5) is located on the blue tube between the RO Module and the RO faucet. Remove it by loosening the compression fittings on both ends. Remove the 3/8" fitting from old filter, re-apply Teflon tape if needed and install on the new in-line filter. Install new in-line filter on to the blue tube.

Note: *The arrow on the final filter must be pointing towards the RO faucet / away from the RO Module.*

Tip: *This is a good time to check the air pressure in your storage tank. For instructions please see page 16.*

Step 11 Follow Steps 8 through 10 in the Six Month System Maintenance (Page 13) for startup directions.

This reverse osmosis system contains a replaceable component (the RO membrane) which is critical to the efficiency of the system. Replacement of this reverse osmosis membrane should be with one of identical specifications as defined by Watts Premier to assure the same efficiency and contaminant reduction performance.

Membrane Replacement

Membranes have a life expectancy between 2 and 5 years, depending on the incoming water conditions and the amount the RO system is used. This reverse osmosis membrane is critical for effective reduction of total dissolved solids (TDS). The product water should be tested periodically to verify that the system is performing satisfactorily. Normally, a membrane would be replaced during a semiannual or annual filter change. However, if at any time you notice a reduction in water production or an unpleasant taste in the reverse osmosis water, it could be time to replace the membrane. Watts Premier recommends replacing the membrane when TDS reduction falls below 75%.

Note: *A water sample may be sent to Watts Premier for a free diagnosis of your membranes performance. To send a water sample, use two (2) clean containers and fill ½ cup of tap water in one container and ½ cup of reverse osmosis water in 2nd container. Clearly label each sample. Send the samples to the address listed on the cover of this manual attention “Water Samples”. Watts Premier will test the water and mail or call you with the results.*

Step 1 Turn off the incoming water supply to the RO by turning the needle valve on the adapt-a-valve clockwise until it stops. (Follow the green tube away from the RO system to find the adapt-a-valve.)

Step 2 Open the RO Faucet and allow water to drain from the tank until it is completely empty.

Step 3 Remove the horizontal membrane housing on top of the unit by turning it counter clockwise to loosen.

Step 4 Pull firmly on the yellow RO membrane to remove it from the housing and discard.

Step 5 Lubricate the O-rings on the new membrane with a water soluble lubricant such as KY Jelly®. Insert the end with the two black O-rings into the cap. Twist the membrane as you push it firmly into the manifold.

Caution: *Before re-installing the membrane housing back on to the system, check O-ring on the housing to make it is still in place and lubricate with water soluble lubricant.*

Step 6 Replace the membrane housing onto the cap by turning clockwise. Tighten securely.

Step 7 Follow Start up instructions on page 11.

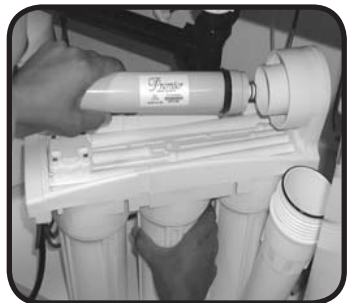

Check Air Pressure in the Tank

Important: Check air pressure only when tank is empty of water!

Check air pressure in the storage tank when you notice a decrease in available water from the RO system. Air can be added with a bicycle pump using the schrader valve that is located on the lower side of the tank behind the blue plastic cap.

Step 1 Turn off the incoming water supply to the RO.

Step 2 Open the RO Faucet and allow water to drain from the tank until it is completely empty.



Tip: When water from the RO faucet slows to a trickle, with the faucet still in the open position, you may add air to the tank to purge any left over water, this will ensure that the tank is completely empty.

Step 3 Once all water in the tank is purged, check air pressure using an air pressure gauge, it should read between 5 - 7 PSI. (Digital air pressure gauge is recommended)

Step 4 Follow startup procedure on page 12.

Procedure for Extended Non-Use (More than 2 months)

Turn off the water supply to the RO system at the adapt-a-valve and open the RO faucet to empty the storage tank (Save a few ounces of RO water). Once the storage tank is empty, remove the membrane and place it in a sealed plastic bag with the RO water saved earlier and store in your refrigerator.

For restart, reinstall membrane and follow startup procedure on page 12.

TROUBLE SHOOTING

Problem	Cause	Solution
1. Low/Slow Production	<p>Low Water Pressure</p> <p>Crimps in tubing Clogged pre-filters Fouled membrane</p>	<p>Assure a minimum of 40 psi incoming water pressure. Premier sells a booster pump if home water pressure is low. Make sure water supply is turned on and feed water valve is all the way open.</p> <p>Check tubing and straighten or replace as necessary. Replace pre-filters. Replace membrane.</p>
2. Milky colored Water	Air in system	Air in the system is a normal occurrence with initial start up of the RO system. This milky look will disappear during normal use within 1-2 weeks. If condition reoccurs after filter change, drain tank 1 to 2 times.
3. Water constantly running, unit will not shut off	<p>Low water pressure</p> <p>Crimp in supply tube High water pressure</p> <p>High pressure in Tank</p> <p>Low Pressure in Tank</p>	<p>See #1 Above</p> <p>Check tubing and straighten or repair as necessary. Check incoming water pressure to make sure it does not exceed 80 psi. A pressure relief valve may be necessary.</p> <p>Empty storage tank of water. Set tank air pressure between 5-7 psi. See previous page.</p> <p>Use a Digital Air Gauge for best results. The empty tank pressure should be 5-7 psi. See page 16.</p>
4. Noise / Water from faucet vent hole or noise from drain.	<p>Crimp or restriction in drain line</p> <p>Drain tube clogged</p>	<p>Check tubing and straighten or repair as necessary. Straighten all drain lines. Clear blockage. Cut off any Excess tubing</p> <p>Caused from dishwasher or garbage disposal. Disconnect the 3/8" black line at the drain, clean the 3/8" black line out with a wire, then reconnect. Blowing air through the line will not always remove the clog.</p>
5. Small amount of water in storage tank	<p>System starting up</p> <p>Low water pressure To much air in tank</p>	<p>Normally it takes 4-6 hours to fill tank. Note: low incoming water pressure and/or temperature can drastically reduce production rate.</p> <p>See #1 above.</p> <p>Tank air pressure should be 5-7 psi when empty of water. If below 5 psi add air or bleed if above 7 psi. Check only when tank is empty of water. See previous page.</p>
6. Water leaks from the blue or white filter housing	<p>Not properly tightened</p> <p>Kinked O-ring</p>	<p>Tighten the bowl.</p> <p>Turn off the water supply and release the pressure. Replace the O-ring if necessary. Then lubricate it and make sure the O-ring is seated in the filter bowl properly before reinstalling the filter bowl.</p>
7. Low water flow from faucet	Check air pressure in tank	Use a Digital Air Gauge for best results. The empty tank pressure should be 5-7 psi. See page 16.

TECHNICAL & WARRANTY INFORMATION

Performance Data Sheet WP-5, KP-5, RO5-M

Watts Premier Inc.
8716 W Ludlow Drive Suite #1
Peoria, AZ 85381
(480) 675-7995 wpmail@watts.com

GENERAL USE CONDITIONS:

1. System to be used with municipal or well water sources treated and tested on regular basis to insure bacteriological safe quality. DO NOT use with water that is microbiologically unsafe or unknown quality without adequate disinfection before and after the system. Systems certified for cyst reduction may be used on disinfected water that may contain filterable cysts.
2. Operating Temperature: Maximum: 100°F (40.5°C) Minimum: 40° (4.4°)
3. Operating Water Pressure: Maximum: 85 psi (7.0kg/cm2) Minimum: 40 psi (2.8kg/cm2)
4. pH 2 to 11
5. No iron present in incoming feed water supply.
6. Hardness of more than 10 grains per gallon (170 ppm) may reduce TFM membrane life expectancy.
7. Recommend TDS (Total Dissolved Solids) not to exceed 1800 ppm.



RECOMMENDED REPLACEMENT PARTS AND CHANGE INTERVALS:

Note: Depending on incoming feed water conditions replacement time frame may vary.

Description	Change time Frame	Cost
Sediment Pre-filter: #104017	6 Months	\$3.50
Carbon Pre-filter: #101009	6 Months	\$10.50
Final Carbon filter #100017	12 Months	\$9.50
R.O. Membrane: #110009	2 to 5 years	\$59.95

* All Prices Subject to change without notice

This system has been tested according to NSF/ANSI 58 for reduction of the substances listed below. The concentration of the indicated substances in water entering the system was reduced to a concentration less than or equal to the permissible limit for water leaving the system as specified in NSF/ANSI 58. This system has been tested for the treatment of water containing pentavalent arsenic (also known as As (V), As (+5), or arsenate) at concentrations of 0.30 mg/L or less. This system reduces pentavalent arsenic, but may not remove other forms of arsenic. This system is to be used on water supplies containing a detectable free chlorine residual at the system inlet or on water supplies that have been demonstrated to contain only pentavalent arsenic. Treatment with chloramine (combined chlorine) is not sufficient to ensure complete conversion of trivalent arsenic to pentavalent arsenic. Please see the Arsenic Facts section of the Performance Data Sheet for further information.

	Avg. In.	Avg. Eff.	% Reduction	pH	Pressure	Max Eff.	Inf. challenge concentration mg/L	Max Allowable concentration mg/L
Arsenic (Pentavalent)	334.615 ug/L	5.0385 ug/L	98.4%		50psi	19 ug/L	0.30±10%	0.010 mg/L
Barium Reduction	10.2 mg/L	0.207 mg/L	97.9%	7.24	50psi	0.3 mg/L	10.0±10%	2.0
Cadmium Reduction	0.036 mg/L	0.0005 mg/L	98.6%	7.49	50psi	0.0007	0.03±10%	0005
Chromium (Hexavalent)	0.15 mg/L	0.013 mg/L	91.3%	7.24	50psi	0.03	0.3±10%	0.1
Chromium (Trivalent)	0.17 mg/L	.01 mg/L	94.1%	7.24	50psi	0.01	0.3±10%	0.1
Copper Reduction	3.1 mg/L	0.03 mg/L	99.0%	7.64	50psi	0.04	3.0±10%	1.3
Cysts	222,077#/ml	10 #/ml	99.99%			58	minimum 50,000/mL	
Fluoride Reduction	8.0 mg/L	0.5 mg/L	93.9%	7.49	50psi	0.7	8.0±10%	1.5
Lead Reduction	0.15 mg/L	0.002 mg/L	98.6%	7.49	50psi	0.003	0.15±10%	0.010
Perchlorate	0.10 mg/L	0.003 mg/L	96.5%	7.39	50 psi	0.005	0.10±10%	0.006
Radium 226/228	25pCi/L	5pCi/L	80.0%	7.24	50psi	5pCi/L	25pCiL±10%	5pCiL
Selenium	0.10	0.008	92.0%		50psi	0.011	0.10±10%	0.05
TDS	765	23 mg/L	96.8%	7.84	50 psi	33 mg/L	750±40mg/L	187
Turbidity	10.2 mg/L	0.26 mg/L	97.5%			0.83	11±1 NTU	0.5 NTU

Recovery - 16.23%

Daily Production Rate - 9.56 GPD

Efficiency - 9.58%

Depending on water chemistry, water temperature, and water pressure Watts Premier's R.O. Systems production and performance will vary.

Efficiency rating means the percentage of the influent water to the system that is available to the user as reverse osmosis treated water under operating conditions that approximate typical daily usage. Recovery rating means the percentage of the influent water to the membrane portion of the system that is available to the user as reverse osmosis treated water when the system is operated without a storage tank or when the storage tank is bypassed. There is an average of 4 gallons of reject water for every 1 gallon of product water produced.

REFER TO OWNER'S INSTALLATION/SERVICE MANUAL FOR FURTHER MAINTENANCE REQUIREMENTS AND WARRANTY INFORMATION.

Phone: (480) 675-7995

Fax: (623) 866-5666

Email: wpmail@watts.com

Performance Data Sheet

B-RO5M-50, WP5-50

Watts Premier Inc.
8716 W Ludlow Drive Suite #1
Peoria, AZ 85381
(480) 675-7995 wpmail@watts.com

GENERAL USE CONDITIONS:

1. System to be used with municipal or well water sources treated and tested on regular basis to insure bacteriological safe quality. Do not use with water that is microbiologically unsafe or unknown quality without adequate disinfection before and after the system. Systems certified for cyst reduction may be used on disinfected water that may contain filterable cysts.
2. This system is acceptable for treatment of influent concentrations of no more than 27 mg/L nitrate and 3 mg/L nitrite in combination measured as N and is certified for nitrate/nitrite reduction only for water supplies with a pressure of 280 kPa (40 psig) or greater. If your water supply is under 40 psi, Watts Premier recommends the use of a RO booster pump for proper operation.
3. Operating Temperature: Maximum: 100°F (40.5°C) Minimum: 40° (4.4°)
4. Operating Water Pressure: Maximum: 85 psi (7.0kg/cm2) Minimum: 40 psi (2.8kg/cm2)
5. pH 2 to 11
6. Hardness of more than 10 grains per gallon (170 ppm) may reduce TFM membrane life expectancy.
7. Recommend TDS (Total Dissolved Solids) not to exceed 1800 ppm.



RECOMMENDED REPLACEMENT PARTS AND CHANGE INTERVALS:

* All Prices Subject to change without notice

Note: Depending on incoming feed water conditions replacement time frame may vary.

Description	Change time Frame	Cost
Sediment Pre-filter: #104017	6 Months	\$3.50
Carbon Pre-filter: #101009	6 Months	\$10.50
Final Carbon filter #100017	12 Months	\$9.50
R.O. Membrane: #110019	2 to 5 years	\$80.95

This system has been tested according to NSF/ANSI 58 for reduction of the substances below. The concentration of the indicated substances in water entering the system was reduced to a concentration less than or equal to the permissible limit for water leaving the system as specified in NSF/ANSI 58. This system has been tested for the treatment of water containing pentavalent arsenic (also known as As (V), As (+5), or arsenate) at concentrations of 0.30 mg/L or less. This system reduces pentavalent arsenic, but may not remove other forms of arsenic. This system is to be used on water supplies containing a detectable free chlorine residual at the system inlet or on water supplies that have been demonstrated to contain only pentavalent arsenic. Treatment with chloramine (combined chlorine) is not sufficient to ensure complete conversion of trivalent arsenic to pentavalent arsenic. Please see the Arsenic Facts section of the Performance Data Sheet for further information.

	Avg. In.	Avg. Eff.	% Reduction	pH	Pressure	Max Eff.	Inf. challenge concentration mg/L	Max Allowable concentration mg/L
Arsenic (Pentavalent)	334.615 ug/L	5.0385 ug/L	98.4%		50psi	19 ug/L	0.30±10%	0.010
Barium Reduction	10.2 mg/L	0.207 mg/L	97.9%	7.24	50psi	0.3 mg/L	10.0±10%	2.0
Cadmium Reduction	0.036 mg/L	0.0005 mg/L	98.6%	7.49	50psi	0.0007	0.3±10%	0005
Chromium (Hexavalent)	0.15 mg/L	0.013 mg/L	91.3%	7.24	50psi	0.03	0.3±10%	0.1
Chromium (Trivalent)	0.17 mg/L	.01 mg/L	94.1%	7.24	50psi	0.01	0.03±10%	0.1
Copper Reduction	3.1 mg/L	0.03 mg/L	99.0%	7.64	50psi	0.04	3.0±10%	1.3
Cysts	222,077#/ml	10 #/ml	99.99%			58	minimum 50,000/mL	
Fluoride Reduction	8.0 mg/L	0.5 mg/L	93.9%	7.49	50psi	0.7	8.0±10%	1.5
Lead Reduction	0.15 mg/L	0.002 mg/L	98.6%	7.49	50psi	0.003	0.15±10%	0.010
Nitrate & Nitrite	28.8 mg/L	6.6 mg/L	77.0%		50 psi	10 mg/L	30±10%	10.0
Nitrate	26.0 mg/L	6.1 mg/L	76.5%		50 psi	10 mg/L	27±10%	10.0
Nitrite	2.8 mg/L	0.5 mg/L	82.1%		50 psi	0.77mg/L	3.0±10%	1.0
Perchlorate	0.10 mg/L	0.003 mg/L	96.5%	7.39	50 psi	0.005 mg/L	0.10±10%	0.006
Radium 226/228	25 pCi/L	5 pCi/L	80.0%	7.24	50psi	5 pCi/L	25pCiL±10%	5 pCi/L
Selenium	0.10	0.008	92.0%		50psi	0.011	0.10±10%	0.05
TDS	765	23	96.8%	7.84			750±40mg/L	187
Turbidity	10.2 mg/L	0.26 mg/L	97.5%			0.83	11±1 NTU	0.5 NTU

RECOVERY - 13.70%

GALLONS - 9.86 GPD

EFFICIENCY - 6.08%

Depending on water chemistry, water temperature and water pressure Watts Premier's RO Systems production and performance will vary. Efficiency rating means the percentage of the influent water to the system that is available to the user as reverse osmosis treated water under operating conditions that approximate typical daily usage. Recovery rating means the percentage of the influent water to the membrane portion of the system that is available to the user as reverse osmosis treated water when the system is operated without a storage tank or when the storage tank is bypassed. There is an average of 4 gallons of reject water for every 1 gallon of product water produced. Testing performed under standard laboratory conditions, actual performance may vary. Refer to owners manual for further maintenance requirements and warranty information.

Phone: (480) 675-7995

Fax: (623) 866-5666

Email: wpmail@watts.com

California Certification

State of California
Department of Public Health
Water Treatment Device
Certificate Number

00 - 1452

Date Issued: October 17, 2005

Trademark/Model Designation

Watts Premier Deluxe Plus
Watts Premier Ultra 5
Watts Premier PUR-TEK
Watts Premier Watts 25
Watts Premier RO-TFM-5SV
Watts Premier RO-TFM-4SM
Watts RO-4
Watts RO-5
Watts Premier WP-5
Watts Premier WP-4
Watts Premier KP-4
Watts Premier KP-5
Watts Premier RO-4M
Watts Premier RO-5M

Replacement Elements:

sediment prefilter: 5M-10
carbon prefilters: 5M-CB or 56 cu.in. GAC
membrane: TFM-24
post filter: 1M-6 or 1M-10

Manufacturer: Watts Premier, Inc.

The water treatment device(s) listed on this certificate have met the testing requirements pursuant to Section 116830 of the Health and Safety Code for the following health related contaminants:

Microbiological Contaminants and Turbidity

Cysts
Turbidity

Organic Contaminants

None

Inorganic/Radiological Contaminants

Arsenic¹
Barium
Cadmium
Chromium (hexavalent)
Chromium (trivalent)
Copper
Fluoride
Lead
Radium 226/228
Selenium
Perchlorate (≤ 100 ug/L)²

Rated Service Capacity: not applicable

Rated Service Flow: 9 gallons per day

Do not use where water is microbiologically unsafe or with water of unknown quality, except that systems certified for cyst reduction may be used on disinfected waters that may contain filterable cysts.

¹ Claims for arsenic reduction shall only be made on water supplies maintaining detectable residual free chlorine at the reverse osmosis (RO) system inlet. Water systems using an in-line chlorinator should provide a minimum of 1 minute chlorine contact time before the RO system.

² This system is acceptable for treatment of influent perchlorate concentrations of no more than 100 ug/L.

Arsenic Fact Sheet

Arsenic (As) is a naturally occurring contaminant found in many ground waters. Arsenic in water has no color, taste or odor. It must be measured by an arsenic test kit or lab test. Public water utilities must have their water tested for arsenic. You can obtain the results from your water utility contained with in your consumer confidence report. If you have your own well, you will need to have the water evaluated. The local health department or the state environmental health agency can provide a list of test kits or certified labs.

There are two forms of arsenic: pentavalent arsenic (also called As (V), As (+5))and trivalent arsenic (also called As (III), As (+3)). In well water, arsenic may be pentavalent, trivalent, or a combination of both. Although both forms of arsenic are potentially hazardous to your health, trivalent arsenic is considered more harmful than pentavalent arsenic.

RO systems are very effective at removing pentavalent arsenic. A free chlorine residual will rapidly convert trivalent arsenic to pentavalent arsenic. Other water treatment chemicals such as ozone and potassium permanganate will also change trivalent arsenic to pentavalent arsenic. A combined chlorine residual (also called chloramine) may not convert all the trivalent arsenic. If you get your water from a public water utility, contact the utility to find out if free chlorine or combined chlorine is used in the water system.

This Watts Premier reverse osmosis system is designed to remove up to 98% of pentavalent arsenic. It will not convert trivalent arsenic to pentavalent arsenic. Under laboratory standard testing conditions, this system reduced 0.30 mg/L (ppm) pentavalent arsenic to under 0.010 mg/L (ppm) (the USEPA standard for drinking water). Actual performance of the system may vary depending on specific water quality conditions at the consumer's installation.

The RO component of this Watts Premier reverse osmosis system must be maintained according to its recommended maintenance cycle. Specific component identification and ordering information can be found in the installation/operation manual maintenance section, by phone at 1-800-752-5581 or online www.wattspremier.com.

California Proposition 65 Warning

WARNING: this product contains chemicals known to the State of California to cause cancer and birth defects or other reproductive harm. (Installer: California law requires that this warning be given to the consumer). For more information: www.wattsind.com/prop65.

Other Products from WATTS Premier

Watts Premier has other fine water filtration products and accessories to enhance your water and to compliment your existing RO System. Listed on the next several pages are just few of the items we have to offer. Visit our web site at www.wattspremier.com or call our Customer Service Representatives at 1-800-752-5582 (inside USA) 1-480-675-7995 (outside USA) for more products.



Premium Plus Annual Filter replacement kit

Compatible with all Watts Premier Reverse Osmosis and water filtration systems. These filters provide an extra level of filtration by allowing for more contact between the carbon media and your water. Includes a 10" Final in-line Filter, Sediment Filter, Two Carbon Block Filters and a Filter Wrench.

Part No. 560067

***\$33.95 each**



50 GPD Membrane

Compatible with Watts Premier Reverse Osmosis systems, this 50 GPD membrane generates a greater amount of water per day for your RO system. Good application for households with higher levels of Nitrites & Nitrates. Contact Watts Premier if you are in need of a Nitrite/Nitrate test kit.

Part No. 110019 (50 GPD Membrane)

***\$ 80.95/ea**



Ice Maker Installation Kit

1/4 inch connection kit includes 30 feet of 3/8" tubing, ball valve, and fittings.

Part No. 500010

***\$16.95/ea**



Watts Premier Hot Water Recirculation System

Bring convenience and saving to your home, giving you hot water instantly at every faucet, when you need it. This unique product is easy to install and not only provides you with the convenience of hot water when you need it, but saves an average of over 15,000 gallons per year.

Part No. 500800

***\$ 229.99 each**



PERMEATE PUMP KIT

Using only the available energy from the brine water (otherwise lost to the drain), the pump forces product water into the storage tank. This process effectively reduces membrane back pressure to less than 5 psi and allows the membrane to maximize its use of the available feed pressure.

- Fills product tank up to 4 times more rapidly
- Reduces waste water by as much as 80%
- Lowers "TDS creep"
- NSF approved (Standard 58)

Part No. 560041

***\$ 65.95/ea**

****All prices subject to change without notice.***



Top Mount Faucets by Watts Premier

These attractively designed faucets feature a long reach spout to compliment all styles of kitchen decor. The unique top mount design allows for easy above counter installation. The Monitored version of this faucet has an LED light that turns red to notify you for filter replacement.

- | | |
|---|----------------------|
| Part No. 116091 - Chrome (Non-Monitored) | *\$47.95 each |
| 116095 - Brushed Nickel (Non-Monitored) | *\$52.95 each |
| 116094 - Chrome (Monitored) | *\$57.95 each |
| 116093 - Brushed Nickel (Monitored) | *\$62.95 each |



Watts Premier Ice Maker Filter Kit

High efficiency replaceable filter that can last up to 5 years or 20,000 gallons. Perfect for residential and commercial ice makers as well as refrigerators, drinking fountains, coffee & tea brewers, motor homes and campers. Reduces chlorine taste and odor.

- | | |
|------------------------|--------------------|
| Part No. 500318 | *\$32.95/ea |
|------------------------|--------------------|



Water Pressure Gauge

This gauge mounts onto your outside hose connection to accurately show your home's water pressure up to 300 psi. A red needle shows peak overnight pressure, which may exceed readings during the day. High pressure readings may indicate the need for a pressure regulator to prevent damage to appliances.

- | | |
|------------------------|--------------------|
| Part No. 261003 | *\$11.50/ea |
|------------------------|--------------------|



Pocket Total Dissolved Solids (TDS) Monitor

Test water electronically to verify reverse osmosis membrane effectiveness. Carrying case included.

- | | |
|------------------------|--------------------|
| Part No. 273001 | *\$39.95/ea |
|------------------------|--------------------|



Whole House High Performance Water Pressure Regulator

Provides water pressure control solutions for residential, commercial, and industrial applications. Offers durability and years of continuous trouble free operation.

- | | |
|------------------------|----------------------|
| Part No. 107001 | *\$69.95 each |
|------------------------|----------------------|



Whole House Filter

Great for sediment problems such as in well water supply or areas where dirt and rust particles are a problem. Includes three 50 micron sediment filters and wrench (3/4" ports)

- | | |
|------------------------|--------------------|
| Part No. 500223 | *\$42.95/ea |
|------------------------|--------------------|

Replacement filter

- | | |
|------------------------|--------------------|
| Part No. 304007 | *\$ 4.50/ea |
|------------------------|--------------------|

** All prices subject to change without notice.*

Removing chlorine from your shower

Special Chlorgon & KDF media – More effective than carbon medias with hot water applications in the removal of the following.

- √ Free Chlorine (CL-)
- √ Combined Chlorine (Sodium Hypochlorite)
- √ Hydrogen Sulfide (Rotten egg smell)
- √ Plus, its pH balanced.
- √ Iron oxide (rust water)
- √ Dirt, sediment
- √ Odors



Deluxe Shower Handle with Built in Filter

5-Way Massaging Spray
72" Reinforced Hose
High Strength Bracket
Triple Plated Finish
Reversible Filter Cartridge (Model HHC)
Cartridge Life Rating: 3 months

Part No. 107070 WHITE *\$38.95
Part No. 107091 CHROME *\$44.95
Part No. 107092 GOLD *\$44.95

Replacement filters 2PK



Part No. 107075 *\$15.95/pk



Shower Falls Deluxe Shower Handle with Built in Filter

Curved Ergonomic Shower Handle
Filter Handle Extension
Dual Swivel Adjustment
Ultra Deluxe 5 Way Massaging Spray
72" Reinforced Hose
Chrome Plated Brass Bracket & Swivel Ball Extension
Triple Plated Finish
Reversible Filter Cartridge (Model HHC)
Cartridge Life Rating: 3 months

Part No. 107095 CHROME *\$55.95

Replacement filters 2PK



Part No. 107075 *\$15.95/pk



All-In-One reversible High-Flow Filter

Deluxe 5-Way Massaging Spray

Soft-Touch Adjustment Pads
Anti-Scaling Spray Nozzle
High Strength Housing
Triple Plated Finish
Cartridge Life Rating: 6 months

Part No. 107098 White/Chrome *\$39.95

Replacement filter



WATTS Premier

Part No. 107080 *\$13.95/ea

***All prices subject to change without notice.**

Limited Warranty

What your Warranty Covers:

If any part of your WATTS PREMIER Reverse Osmosis System is defective in workmanship (excluding replaceable filters and membranes), return unit after obtaining a return authorization (see below), less tank, within 3 year of original retail purchase, WATTS PREMIER will repair or, at WATTS PREMIER'S option, replace the system at no charge.

How to obtain Warranty Service:

For warranty service, call 1-800-752-5582 for a return authorization number. Then, ship your Reverse Osmosis unit (less tank) to our factory, freight and insurance prepaid, with proof of date of original purchase. Please include a note stating the problem. Premier will repair it, or replace it, and ship it back to you prepaid.

What this warranty does not cover:

This warranty does not cover defects resulting from improper installation, (contrary to WATTS PREMIER'S printed instructions), from abuse, misuse, misapplication, improper maintenance, neglect, alteration, accidents, casualties, fire, flood, freezing, environmental factors, water pressure spikes or other such acts of God.

This warranty will be void if defects occur due to failure to observe the following conditions:

1. The Reverse Osmosis System must be hooked up to a potable municipal or well cold water supply.
2. The hardness of the water should not exceed 7 grains per gallon, or 120 ppm.
3. Maximum incoming iron must be less than 0.2 ppm.
4. The pH of the water must not be lower than 2 or higher than 11.
5. The incoming water pressure must be between 40 and 100 pounds per square inch.
6. Incoming water to the RO cannot exceed 105 degrees F (40 degrees C.)
7. Incoming TDS/Total Dissolved Solids not to exceed 1800 ppm.
8. Do not use with water that is microbiologically unsafe or of unknown quality without adequate disinfection before or after the system.

This warranty does not cover any equipment that is relocated from the site of its original installation.

This warranty does not cover any equipment that is installed or used outside the United States of America and Canada.

LIMITATIONS AND EXCLUSIONS:

WATTS PREMIER WILL NOT BE RESPONSIBLE FOR ANY IMPLIED WARRANTIES, INCLUDING THOSE OF MERCHANTABILITY AND FITNESS FOR A PARTICULAR PURPOSE. PREMIER WILL NOT BE RESPONSIBLE FOR ANY INCIDENTAL OR CONSEQUENTIAL DAMAGES, INCLUDING TRAVEL EXPENSE, TELEPHONE CHARGES, LOSS OF REVENUE, LOSS OF TIME, INCONVENIENCE, LOSS OF USE OF THE EQUIPMENT, AND DAMAGE CAUSED BY THIS EQUIPMENT AND ITS FAILURE TO FUNCTION PROPERLY. THIS WARRANTY SETS FORTH ALL OF PREMIER'S RESPONSIBILITIES REGARDING THIS EQUIPMENT.

OTHER CONDITIONS:

If PREMIER chooses to replace the equipment, WATTS PREMIER may replace it with reconditioned equipment. Parts used in repairing or replacing the equipment will be warranted for 90 days from the date the equipment is returned to you or for the remainder of the original warranty period, whichever is longer. This warranty is not assignable or transferable.

YOUR RIGHTS UNDER STATE LAW:

Some states do not allow limitations on how long an implied warranty lasts, and some states do not allow the exclusion or limitation of incidental or consequential damages, so the above limitations or exclusions may not apply. This warranty gives you specific legal rights, and you may have other legal rights which vary from state to state.