



4090-21-SD

2-Head, 1-Direction or 2- Direction, 1- Channel, Standard Detector

TOMAR's 4090-21-SD Strobecom II single or dual direction preemption detector includes two detector heads and one output channel.

The 4090-21-SD senses the optical pulses emitted by properly equipped emergency & transit vehicles. Mounted to observe an approach to an intersection, the 4090-21-SD is used with TOMAR 4000V2 Series optical signal processors to inform the traffic control system.



- Tool-less swivel of detector head makes aiming easy
- Sensor technology for sunlight rejection unmatched by any other system
- Fully encapsulated electronics for complete resistance to water, heat, and vibration
- Protected from mis-wiring and electrical transients
- Simple advance detector installation for detection around corners and over hills

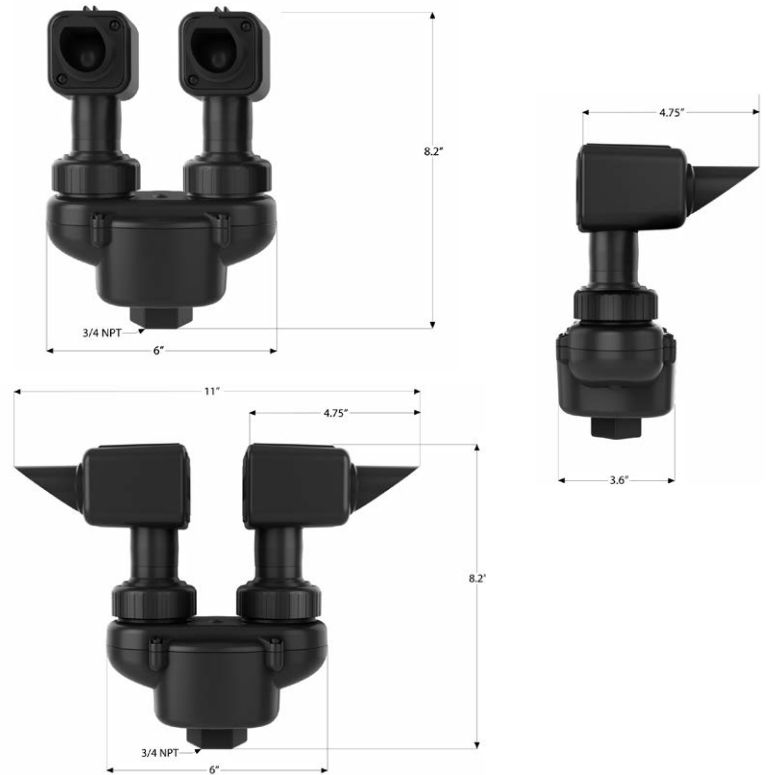



Specifications

Item	Description
Maximum Detection Range	2500 feet minimum when used with 4000V2 series optical signal processor in clear atmospheric conditions
Maximum Cable Length	Up to 900 feet of TOMAR M913 preemption cable between optical signal processor and 4090-21-SD
Field of View	13 degrees conical centered around viewport normal axis (typical)
Cable Type	TOMAR model M913 preemption detector cable 20 AWG 3-conductor shielded cable & bare
Operating Temperature	-40 to +75 degrees C
Physical Construction	The 4090-21-SD enclosure is black, glass filled, UV stabilized polyamide suitable for all weather use. All electronics circuitry is completely encapsulated in polyurethane for protection from shock, vibration, and moisture.
Mounting	The 4090-21-SD is easily mounted using standard hardware on either span wire or mast arm. The unit has a 3/4" female pipe mount hub and internal terminal block for connection to a 3/C shielded detector cable (TOMAR M913)

Ordering Info

Catalog Number	Description
4090-21-SD	Two head, single or dual direction, one channel, optical signal detector

TRUE 10 YEAR WARRANTY!

10 year warranty covers the 4000 Series and all STROBECOM II components. Unlike other manufacturers, TOMAR's ten year warranty has NO fees or charges for warranty repairs after five years.

NOTICE: The sale of these items are restricted to state and local governments and to be authorized distributors only.