

**FWCDR6628-24S WINE COOLER**  
**FORNO ALTA QUALITA 24" BUILT-IN**  
**COMPRESSOR WINE COOLER, 108 bottles**

**Specifications:**

Capacity: 16.25Cu. F. (108 bottles)  
 Two Drawers: 100 cans (may vary in size and dimension)  
 Zone: dual  
 Upper: 5-22° C(41-72° F)  
 Lower: 1-8° C (34-46° F)  
 Shelves: 9 pieces metal shelves+black wood decor  
 Door Panel: Stainless steel door frame  
 Handle type: FORNO handle  
 Voltage/Frequency: 115Volt/60Hz  
 Rated power: 150W  
 Refrigerant: R600a.  
 Foaming agent: cyclopentane

**Features:**

- Intelligent thermostat system
- Double layer anti-UV glass door
- 9 pcs sliding metal shelves + front black wooden trim
- Seamless SS door frame ( no gap at the corner)
- Blue vertical LED light at two sides
- Touch screen control panel
- Charcoal filter makes inner air fresh
- High efficient compressor
- Auto defrost

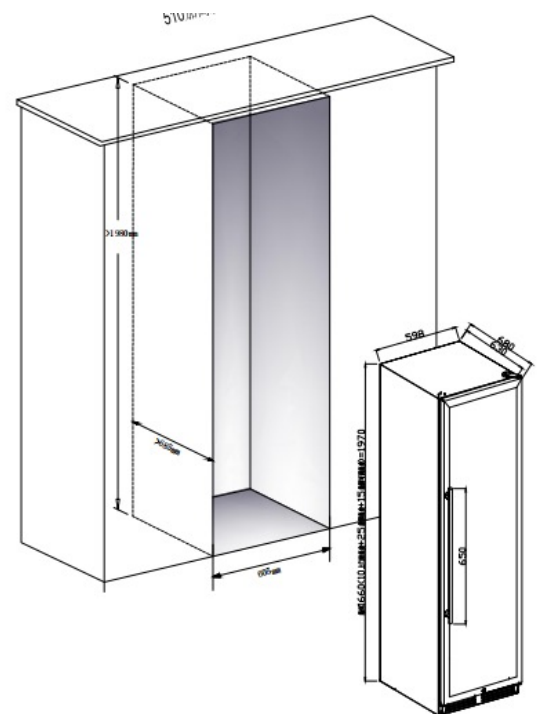

**Product Dimension:**  
 (W x D x H) (in): 23.54"x27.17"x76.77"  
 Weight: 220 lbs