

Preparing your Dip Coater for Return

- Firstly, remove the Dip Coating arm from the Safety Switch Housing. In 'Manual Mode' lower the arm shaft to the maximum travel distance. Then move the shaft back up by around 4mm.

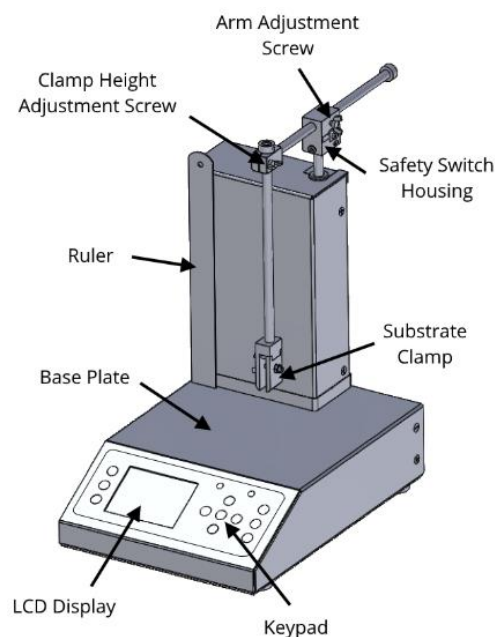

Packing List

Items to be returned:

- Dip Coater
 - Power Cable
 - Power Cable
 - Dip Coating Arm (removed from the unit)
-

- **Note:** Make sure to bubble wrap the Safety Switch Housing as this is a delicate part that requires protection for shipping.
- If you have the original foam packaging, Ossila branded box and outer box, please follow steps I-VIII. Otherwise, follow steps 1-6.
 1. Wrap the equipment in three layers of bubble wrap (or similar packaging material).
 2. Place the unit and power cable in a suitable size shipping box (there should be a roughly 2.5cm gap between the unit and the box walls).
 3. Fill any empty space with packaging void fill (or similar packing material).
 4. Securely seal the shipping box and attach the shipping documentation and shipping labels as instructed by Ossila.
 5. Write the RMA number clearly on the outside of the box.
 6. Await collection of your return.

- I. Place the unit into the custom cut foam and the into the Ossila branded box.
- II. Place the power adapter and power cable in the Ossila branded box.
- III. Fold down the flaps and seal the branded box.
- IV. Place 4 foam corner parts into the bottom of the brown outer box and then suspend the Ossila branded box on top of the corner parts. Place the remaining 4 corner foam parts on each corner of the branded box.



- V. Fold down the flaps of the brown outer box and seal along the centre of the box.
- VI. Attach the shipping documentation and shipping labels as instructed by Ossila.
- VII. Write the RMA number clearly on the outside of the box.
- VIII. Await collection of your return.